



Instruction for use

C6 COMPACT 3

Installation

Translation of the original manual

Document 20372037 EN 06

Imprint

KEB Automation KG
Suedstraße 38, D-32683 Bartrup
Germany
Tel: +49 5263 401-0 • Fax: +49 5263 401-116
E-Mail: info@keb.de • URL: <https://www.keb-automation.com>

ma_ca_c6-compact3-inst-20372037_en
Version 06 • Edition 11/12/2025

Table of contents

1	Introduction	6
1.1	Markings.....	6
1.1.1	Warnings.....	6
1.1.2	Information notes	6
1.1.3	Symbols and markers	7
1.2	Laws and guidelines.....	7
1.3	Warranty and liability.....	7
1.4	Support.....	7
1.5	Copyright.....	8
1.6	Open Source Information	8
1.7	Validity of this manual	9
1.8	Target group.....	9
2	General Safety Instructions.....	10
2.1	Installation	10
3	Product description	11
3.1	Scope of delivery.....	11
3.2	Product features.....	11
3.2.1	Fieldbus interfaces.....	12
3.2.2	Ethernet protocols.....	12
3.2.3	Programming and visualisation.....	13
3.2.4	Flash memory	13
3.3	Product identification.....	14
3.3.1	Nameplate	14
3.3.2	Type code	15
3.4	Release notes	15
3.5	Intended use	15
3.6	Unintended use	15
3.7	Description of the device.....	16
3.7.1	Front view	16
3.7.2	Top view	17
3.7.3	View from below	19
3.7.4	Rear view all models.....	20
4	Technical data	21
4.1	Operating conditions	21
4.1.1	Climatic ambient conditions	21
4.1.2	Mechanical ambient conditions.....	21
4.1.3	Electrical operating conditions	21
4.2	Electrical data.....	22
5	Assembly	23
5.1	Assembly instructions	23
5.2	Dimensions	23
5.3	Mounting direction.....	23
5.4	Minimum installation distances	24
5.5	Mounting of the control.....	24
5.5.1	Mounting on a mounting rail	25

5.5.2	Disassembly of the mounting rail	25
6	Electrical installation	26
6.1	Assembly of wires	26
6.2	Voltage supply.....	26
6.2.1	Terminal block X6	27
6.3	Earthing.....	28
6.4	Equipotential bonding.....	28
6.5	EtherCAT Master X1	29
6.6	Ethernet X2	29
6.7	Ethernet X3	30
6.8	CAN.....	31
6.9	RS485	33
6.10	RS232	34
6.11	INTERBUS interface X10, X11	34
6.11.1	INTERBUS DIP switch S1	35
6.11.2	INTERBUS remote bus cable	35
6.11.3	INTERBUS extension	35
7	Operation	39
7.1	Status displays	39
7.2	Start-up	41
7.2.1	Requirements for start-up	41
7.2.2	Find COMPACT 3 in the network	41
7.2.3	Starting the web interface	43
7.2.4	Login	45
7.2.5	Logout.....	46
7.3	System Manager	47
7.3.1	Overview	47
7.3.2	Network.....	48
7.3.3	Date and time	48
7.3.4	Partitions	49
7.3.5	Log files	49
7.3.6	Device LEDs	50
7.4	Licence Manager.....	50
7.4.1	My licences	50
7.5	App Manager.....	51
7.5.1	Installed apps.....	51
7.6	OS and bootloader update	53
7.6.1	OS Image update.....	53
7.7	SD card handling.....	54
7.7.1	Preparing the SD card	54
7.7.2	Overview of folder structure	55
7.7.3	Sample files	55
7.7.4	Step by step	56
7.8	Device recovery	56
7.9	IIoT Cloud.....	57
7.9.1	Device manager.....	58
8	Maintenance, service and disposal	61
8.1	Maintenance.....	61
8.1.1	Cleaning.....	61

8.1.2	Flash memory	61
8.2	Service	61
8.3	Disposal	62
9	Certification	63
9.1	CE marking	63
9.2	UL certification	63
9.3	Further markings	63
10	Revision History	64
	Glossary	68
	Index	70

1 Introduction

The described devices, accessories, hardware and/or software are products of KEB Automation KG. The enclosed documents correspond to conditions valid at printing. Misprint, mistakes and technical changes reserved.

1.1 Markings

1.1.1 Warnings

Certain operations can cause hazards during the installation, operation or there-after. There is safety information in the documentation in front of these operations.

Warnings contain signal words for the severity of the hazard, the type and/or source of the hazard, the consequence of non-compliance and the measures to avoid or reduce the hazard.

DANGER



Type and/or source of the hazard.

Leads to death or serious bodily injury if not observed.

- a) Measures to avoid the hazard.
- b) Can be supplemented by an additional danger sign or pictogram.

WARNING



Type and/or source of the hazard.

May cause death or serious injury if not observed.

- a) Measures to avoid the hazard.
- b) Can be supplemented by an additional danger sign or pictogram.

CAUTION



Type and/or source of the hazard.

May cause bodily injury if not observed.

- a) Measures to avoid the hazard.
- b) Can be supplemented by an additional danger sign or pictogram.

NOTICE



Type and/or source of the hazard.

Can cause damage to property if not observed.

- a) Measures to avoid the hazard.
- b) Can be supplemented by an additional danger sign or pictogram.

1.1.2 Information notes



Indicates to the user a special condition, prerequisite, scope or simplification.



This is a reference to further documentation. The barcode is for smartphones, the following link is for online users or for typing.

(globe icon) ► <https://www.keb-automation.com/search>



Notes on conformity for use in the North American or Canadian market.

1.1.3 Symbols and markers

✓	Condition
a)	Action step
⇒	Result or intermediate result
(≡▶ Reference ▶ 7)	Reference to a chapter, table or picture with page reference
ru21	Parameter name or parameter index
(🌐▶)	Hyperlink
<Strg>	Control code
COMBIVERT	Lexicon entry

1.2 Laws and guidelines

KEB Automation KG confirms with the CE mark and the EU declaration of conformity that our device complies with the essential safety requirements.

The EU declaration of conformity can be downloaded on demand via our website.

1.3 Warranty and liability

The warranty and liability on design, material or workmanship for the acquired device is given in the general conditions of sale.



Here you will find our general sales conditions.

(🌐▶ <https://www.keb-automation.com/terms-conditions>)



Further agreements or specifications require a written confirmation.

1.4 Support

Through multiple applications, not every possible case has been taken into account. If you require further information or if problems occur which are not treated detailed in the documentation, you can request the necessary information via the local KEB Automation KG agency.

The use of our units in the target products is beyond of our control and therefore exclusively the responsibility of the customer.

The information contained in the technical documentation, as well as any support provided verbally, written or through testing, is made to the best of our knowledge and information regarding intended use of KEB products. However, due to technical changes, any information provided is considered non-binding and is subject to change. This also applies to any violation of industrial property rights of a third-party.

Selection of KEB units in view of their suitability for the intended use must be done by the user.

Tests can only be carried out within the scope of the intended end use of the product (Application) by the Customer. They must be repeated, even if only parts of hardware, software or the unit adjustment are modified.

1.5 Copyright

The customer may use the instructions for use as well as further documents or parts from it for internal purposes. Copyrights are with KEB Automation KG and remain valid in its entirety.

This KEB product or parts thereof may contain foreign software, incl. free and/or open source software. If applicable, the license terms of this software are contained in the instructions for use. The instructions for use are already available, can be downloaded from the KEB website or can be requested from the respective KEB contact person.

Other wordmarks and/or logos are trademarks (™) or registered trademarks (®) of their respective owners.

1.6 Open Source Information

- ✓ Only applies to devices with Linux operating system.
- ✓ This product contains software components.
 - a) We are obliged to point out that the following disclaimer applies to the GPL and LGPL components with regard to the rights holders:

This program is published in the hope that it will be useful, but **without any guarantee**; even without the implied warranty of **marketability** or **usability for a specific purpose**. Further information can be found in the GNU General Public Licence and the GNU Lesser General Public Licence.

For other open source components, the disclaimers of the rights holders in the respective licence texts apply.

The software components contained in this product that are licensed by the rights holder as free software or open source software under a GNU General Public Licence version or a GNU Lesser General Public Licence version or under another open source licence gives you the right to obtain the source code for the binary file. The copyright and the corresponding licence information can be found in the /usr/share/common-licenses folder on the device. The folder is shared and can be accessed from any other PC via the network.

You can obtain the source code for these software components from us on a data carrier (CD, DVD or USB stick) at cost price by sending a request with the order number **00C6DD0-CS01** to the following address within three years of delivery of the product by us:

KEB Automation KG
Legal Department
Südstrasse 38
32683 Barntrup
Germany

Please provide the following information:

Device name, software version information, serial number of the device, delivery date.

Then we will send you an invoice. After receipt of payment you will receive the data carrier with the source code.

1.7 Validity of this manual

These instructions for use are valid for the units specified in the product description. It can be supplemented by corresponding options or special designs. It contains:

- Safety instructions to be observed
- Information on intended use
- Description of the device
- Technical Data
- Installation
- Connection
- Operation
- Maintenance, service and disposal

1.8 Target group

The instructions for use is determined exclusively for electrical personnel. Electrical personnel for the purpose of this instruction manual must have the following qualifications:

- Knowledge and understanding of the safety instructions.
- Skills for installation and assembly.
- Start-up and operation of the product.
- Understanding of the function in the used machine.
- Detection of hazards and risks of the electrical drive technology.
- Knowledge of IEC 60364.
- Knowledge of national safety regulations (e. g. DGUV Regulation 3).
- Knowledge of automation technology.
- Knowledge of PCs and the used operating system.

2 General Safety Instructions

The products are developed and built according to the state of the art and recognized safety rules. Nevertheless, their use may create dangers to life and limb of the user or third parties or damage to the machine and other material property.

The following safety instructions have been created by the manufacturer for the area of electric drive technology. They can be supplemented by local, country- or application-specific safety instructions. This list is not exhaustive. Non-observance of the safety instructions by the customer, user or other third party leads to the loss of all resulting claims against the manufacturer.

NOTICE

Hazards and risks through ignorance!

- a) Read the instructions for use.
- b) Observe the safety and warning instructions.
- c) Ask if something is unclear.

2.1 Installation

DANGER



Electrical voltage in the vicinity of the device!

Danger to life due to electric shock !

- ✓ This device is intended for installation in control cabinets or machines that can be operated under dangerous voltages. For any work on the device
 - a) Switch off the supply voltage of the control cabinet or machine.
 - b) Secure it against switching on.
 - c) Wait until all drives has been stopped in order that no regenerative energy can be generated.
 - d) Never bridge upstream protective devices. Also not for test purposes.

NOTICE



Use of suitable voltage sources!

Electric Shock!

- a) Only voltage sources with safe extra-low voltage in accordance with HD 60364-4-41 may be used.
- b) Ensure that the used voltage supplies have the appropriate overvoltage category for the application.
- c) The requirements listed for SELV and PELV circuits in HD 60364-4-41 must be complied with.
- d) With existing or newly-wired circuits the person installing the device or machine must ensure that the PELV requirements are met.
- e) Connections with higher voltages must be excluded.

3 Product description

The C6 COMPACT 3 is an integrated control for the automation of applications with low to medium complexity. The control concept is based on the Linux operating system and offers an open microservice architecture. Docker technology can be used to integrate and organise various software functions. The system is future-proof thanks to the use of the latest multicore technology and real-time-capable motion control - programmable via IEC 61131-3.

The C6 COMPACT 3 can be used for other tasks in addition to the actual machine automation. It can

- act as a gateway between a higher-level control and a programmable control system with KEB Motion functionality. among other things, an OPC UA server serves as an interface.
- be used as HMI server device. It realises communication with one or more third-party systems and enables browsers to provide content via a HMI server. The microservice architecture of the COMPACT 3 offers simple integration of various software components.

The basic version can be ordered in different hardware and software variants.

3.1 Scope of delivery

The scope of delivery consists of:

C6 COMPACT 3

Terminal block X6

Check the contents of the packaging for visible transport damage and completeness.

If parts are damaged, contact your KEB representative. Do not install any parts damaged by the delivery.

3.2 Product features

C6 COMPACT 3	Model 1	Model 2	Model 3	Model 4 INTERBUS	Optional variants
CPU	64-bit ARM® Cortex®-A53 1GHz Dual Core, single-core Cortex-R5F 800MHz, Single-core Cortex-M4F MCU 400MHz				
Operating system	Linux compact-v3				
Main memory (RAM)	1 GB LPDDR4				up to 2 GB
Internal memory (flash)	eMMC 4 GB				up to 128 GB
Memory card slot	microSD for memory expansion, backup and restore				
X1 10/100 Mbit/s	yes				
X2 10/100 Mbit/s	yes				
X3 10/100/1000 Mbit/s	-	yes	-	-	Option
CAN master/slave	-	-	yes	-	Option
INTERBUS interface	-	-	-	yes	Option
RS232	-	-	-	-	Option
RS485	-	-	-	-	Option
TPM	-	-	-	-	Option
Real-time clock - up to 30 days buffering	-	yes	yes	-	Option
Retentive memory	-	32 kByte	32 kByte	-	Option
EEPROM	32 kB				

C6 COMPACT 3	Model 1	Model 2	Model 3	Model 4 INTERBUS	Optional variants
Program memory	32 MB (CODESYS V3)				
Data storage	128 MB (CODESYS V3)				
Material number	00C6BE1-1 001	00C6BE1-1 002	00C6BE1-1 004	00C6BE1-2 001	upon re- quest

3.2.1 Fieldbus interfaces

X1 socket RJ45

- EtherCAT master 100 Mbit/s

X2 socket RJ45

- Ethernet TCP/IP for diagnostics, configuration, update, HMI server and IIOT, 10/100 Mbit/s

X3 socket RJ45 (variant-dependent)

- Ethernet TCP/IP for diagnostics, configuration, update, HMI server and IIOT, 10/100/1000 Mbit/s

X10 socket D-Sub DE9 (variant-dependent)

- INTERBUS-IN

X11 socket D-Sub DE9 (variant-dependent)

- INTERBUS-OUT

X6 terminal block Push-in terminals (variant-dependent)

- Power Supply; no fieldbus (4 pole)
- Power Supply + CAN (8 pole)
- Power Supply + CAN + RS485 (12 pole)
- Power Supply + CAN + RS232 (16 pole)

3.2.2 Ethernet protocols

- DHCP
- DNS
- NTP
- FTP
- FTPS
- SNMP
- HTTP
- HTTPS
- SSH

3.2.3 Programming and visualisation

Programming environment

- CODESYS V3
- COMBIVIS studio 6

Programming languages in accordance with IEC 61131-3.

- Ladder diagram (LD)
- Function block diagram (FBD)
- Continuous func
- Structured text (ST)
- Sequential function cha

NOA Core

- System Manager (Web-Based)
- App Manager
- Licence Manager
- System Manager
- Message Bus
- NOA Cloud Connector

Visualisation

- HELIO - HMI (Human-Machine Interface) Management System for industrial applications

3.2.4 Flash memory

The internal memory of the C6 COMPACT 3 is based on an eMMC.

With frequent write access, you can also use an external memory to extend the lifetime of the read-only memory.

Make regular backups so that you can access your data in the event of an error.

3.3 Product identification

3.3.1 Nameplate

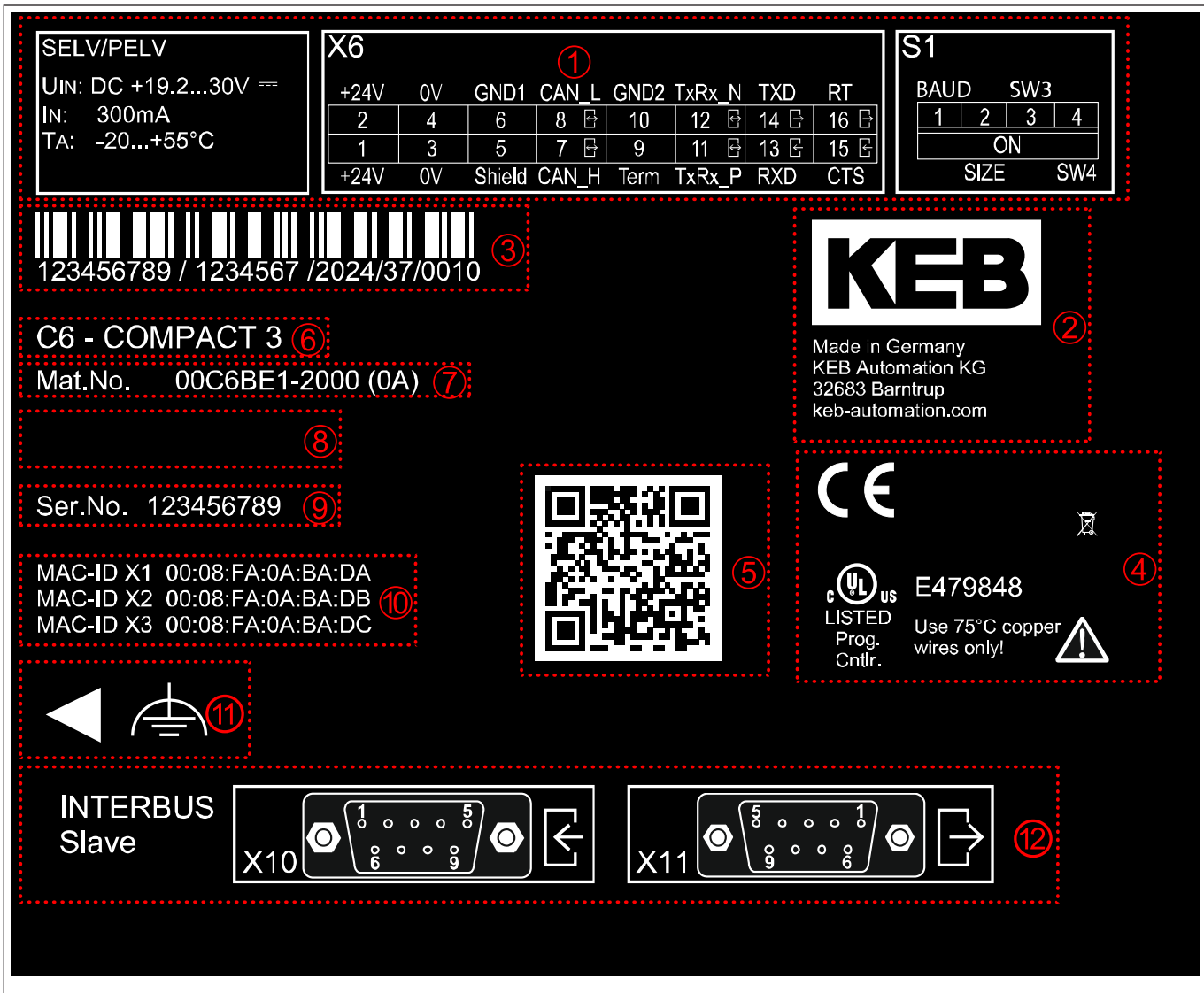

Fig. 1: Nameplate

- | | |
|---|------------------------------------|
| ① Description of the connection elements | ② Manufacturer details |
| ③ Barcode with serial number, order number, year/week of manufacture, plant | ④ Certifications |
| ⑤ Barcode for device identification | ⑥ Series / device designation |
| ⑦ Material number (revision) | ⑧ reserved |
| ⑨ Serial number | ⑩ MAC-Ids (variant-dependent) |
| ⑪ Connection functional earth | ⑫ Description of optional hardware |

3.3.2 Type code

1st and 2nd place	Size or design
00	Standard
3. and 4. digit	Series
C6	Industry automation
5th position	Product type
B	Control
6th position	Control type
E	COMPACT 3
7th position	Configuration
1	Standard
A-Z	Customer version
7th position	Configuration
1	Base device
2	Base device plus expansion card
9./10./11. position	Variant
000	Maximum design
001 ... xxx	See configurable material

3.4 Release notes

The following list describes the validity of the user manual in relation to the hardware.

From revision (=> nameplate)	Description of hardware/change	Instructions	
		from	until
0A	Pre-series.	V00	V04
0B	2A fuse replaced by 0.5 A eFuse. The output current of the supply voltage can thus be significantly reduced.	V05	-

Tab. 1: Release notes

3.5 Intended use

The device is intended for use as an industrial control for processes and machines in a typical industrial environment. The instructions for assembly and installation and compliance with the specified limit values for storage, transport and operation must be observed.

When used as intended, the product does not pose any foreseeable hazards.

3.6 Unintended use

Operating the devices outside the limits specified in the technical data, as well as using them in explosion-endangered areas or in an environment with aggressive corrosive gases, will result in the loss of any claims for damages and the specified approvals/acceptances.

3.7 Description of the device

3.7.1 Front view

3.7.1.1 Model 1 and 3

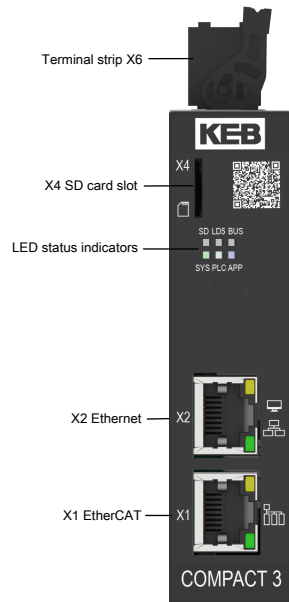

Fig. 2: C6 COMPACT 3 front view of models 1 and 3

3.7.1.2 Model 2

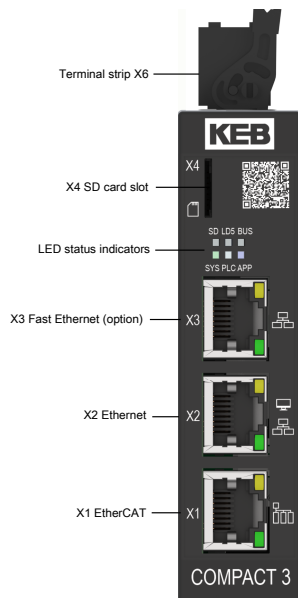

Fig. 3: C6 COMPACT 3 front view model 2

3.7.1.3 Model 4

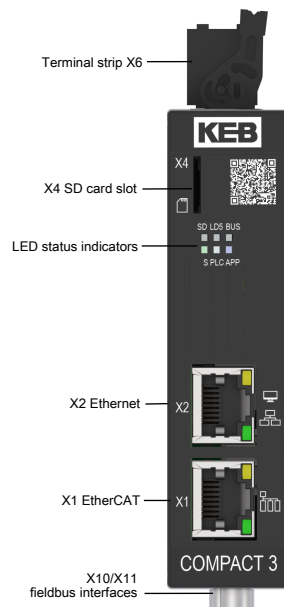

Fig. 4: C6 COMPACT 3 front view model 4

3.7.2 Top view

The displayed view shows the COMPACT 3 with 4-pole connector. Depending on the ordered variant, an 8/12 or 16-pole connector may be installed here.

3.7.2.1 Model 1 and 2

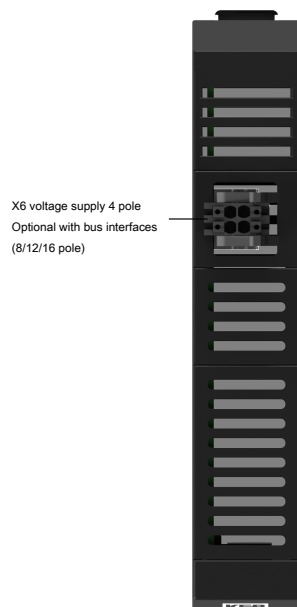

Fig. 5: C6 COMPACT 3 top Model 1 and 2

3.7.2.2 Model 3

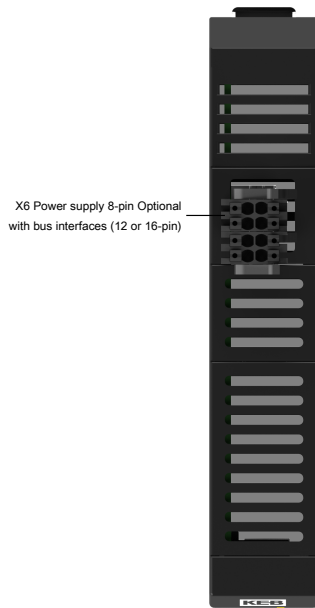

Fig. 6: C6 COMPACT 3 top Model 3

3.7.2.3 Model 4

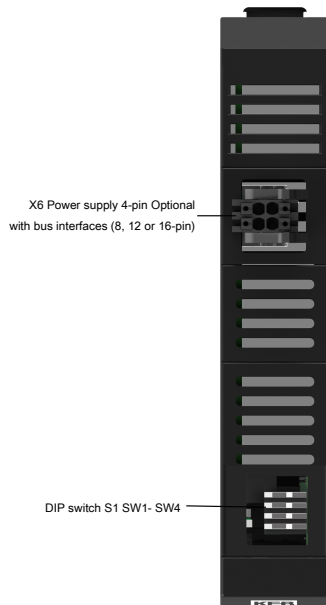

Fig. 7: C6 COMPACT 3 top Model 4

3.7.3 View from below

The variant shown here is the INTERBUS version. No interfaces are installed here for all other variants.

3.7.3.1 Model 1, 2 and 3



Fig. 8: C6 COMPACT 3 bottom Model 1, 2 and 3

3.7.3.2 Model 4

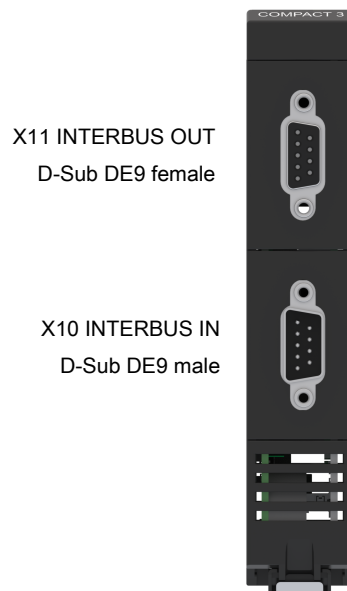

Fig. 9: C6 COMPACT 3 bottom Model 4

3.7.4 Rear view all models

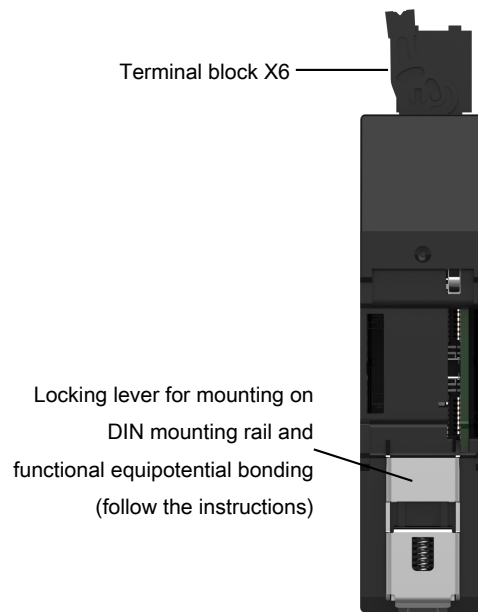

Fig. 10: C6 COMPACT 3 rear view

4 Technical data

4.1 Operating conditions

4.1.1 Climatic ambient conditions

Storage	NORM	Value	Notes
Ambient temperature	EN 61131-2	-40...70 °C	-
Relative humidity	EN 61131-2	10...95 %	without condensation
Transport	Norm	Value	Notes
Ambient temperature	EN 61131-2	-40...70 °C	
Relative humidity	EN 61131-2	10...95 %	without condensation
Operation	Norm	Value	Notes
Ambient temperature	-	-20...55 °C	
Relative humidity	EN 61131-2	10...95 %	without condensation
Degree of protection	EN 60529	IP20	Only suitable for indoor use
Site altitude	-	4000 m	From 2000 m above NHN, the ambient temperature during operation must be reduced by 0.5°C per 100 m.
Pollution degree	EN 61131-2	2	May require installation of the control in a housing with appropriate degree of protection, e.g. IPx4

4.1.2 Mechanical ambient conditions

Operation	Norm	Class	Notes
Vibration limits	EN 61131-2	5...8.4 Hz	7 mm p-p (all 3 axes)
		8.4...150 Hz	1 g (all 3 axes)
Shock limit values	EN 61131-2	15 g, 11 ms	3 pulses per axis and direction

4.1.3 Electrical operating conditions

4.1.3.1 Device classification

Requirement	Norm	Value	Notes
Overvoltage category	EN 61131-2	Cat. II	-
Protection class	IEC 61010-2	III	-

4.2 Electrical data

C6 COMPACT 3	Notes
Rated input voltage	DC 24 V SELV/ PELV protected against polarity reversal
Input voltage range	DC 19,2 V bis 30 V EN 61131-2 und besser)
Rated input current	300 mA
Power input	7.2 W
Internal fusing	2A (slow) Revision 0A 0.5 A (eFuse) from revision 0B onwards
Overvoltage protection	internal
Protection against transient overvoltages	internal
Potential separation 24 V to communication interfaces	DC 1200 V
Basic insulation between 0 V and functional earth	32 V
Real-time clock (RTC)	Charging time (2 h when fully discharged) Buffer time up to 30 days

5 Assembly

5.1 Assembly instructions

To prevent damage to the product, observe the following instructions:

- Make sure that no components are bent and/or isolation distances are changed.
- The product must not be put into operation in case of mechanical defects. Non-compliance with the applicable standards.
- Do not allow moisture, mist or toxic gas to penetrate the product.
- Avoid dust permeating the device. Allow for sufficient heat dissipation if installed in a dust-proof housing.
- Observe minimum installation distances to surrounding elements.
- Do not cover the ventilation openings.
- Install the product in accordance with the required degree of protection (e.g. control cabinet).
- Make sure that no small parts fall into the product during assembly and wiring (drilling chips, screws etc.). This also applies to mechanical components, which can lose small parts during operation.
- Secure the connection cable against mechanical influences (tension, vibrations).

5.2 Dimensions

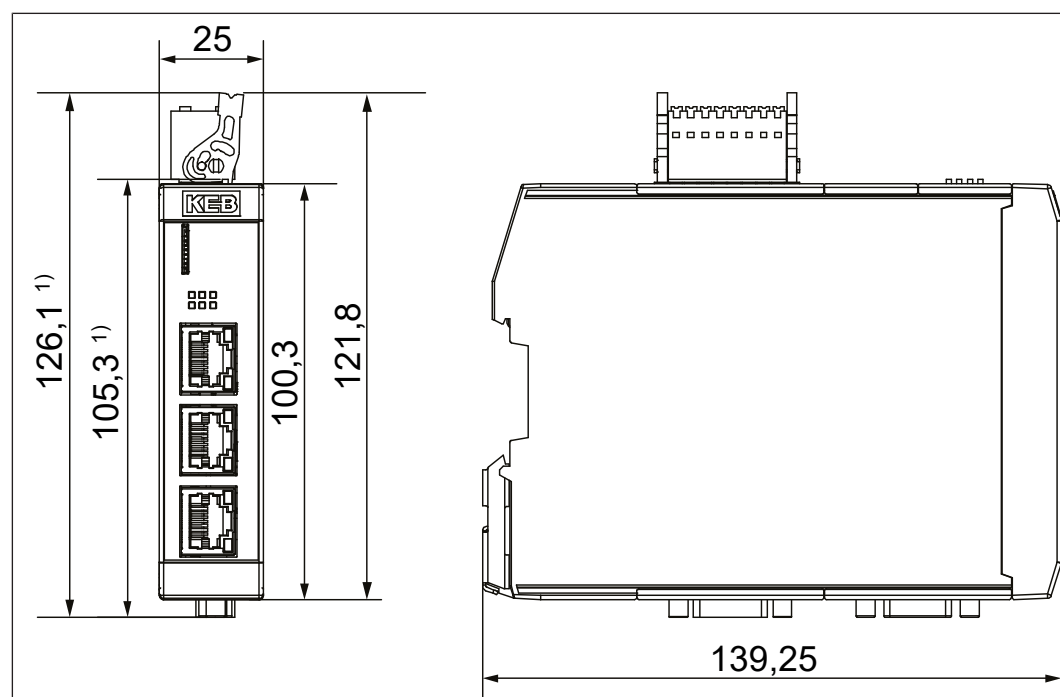

Fig. 11: Dimensions COMPACT 3

1) Model 4 only (INTERBUS)

5.3 Mounting direction

The following mounting orientations are possible without derating:

- typical for control cabinets (mounting rail horizontally on the wall).

5.4 Minimum installation distances

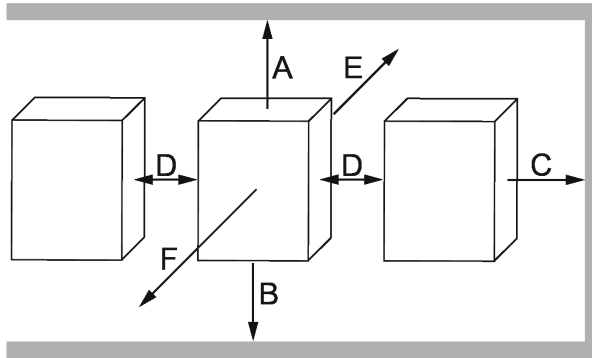

Fig. 12: Installation distances

Dimension	Distance	
A	100 mm	4 inch
B	100 mm	4 inch
C	0 mm	0 inch
D	0 mm	0 inch
E	0 mm	0 inch
F ¹⁾	50 mm	2 inch
1) Distance to upstream control elements in the control cabinet door.		

5.5 Mounting of the control

The control is designed for mounting on a mounting rail. The mounting rail is part of the EMC concept and is therefore **mandatory**. Requirements on the mounting rail:

- The mounting rail must be made of conductive metal.
- Permissible types are TH35/7,5 and TH35/15 in accordance with EN 60715.
- The mounting rail serves as functional earth and must be mounted on a metallic, earthed place (e.g. rear wall of the control cabinet). If this is not possible, the mounting rail must be connected to the functional equipotential bonding via separate connection. The conductor should have a cross section of at least 4 mm².
- To prevent vibration problems, the mounting rail should be connected to the mounting bracket maximally every 200 mm.
- Ensure that there is no heat build-up in a multi-level structure.

5.5.1 Mounting on a mounting rail

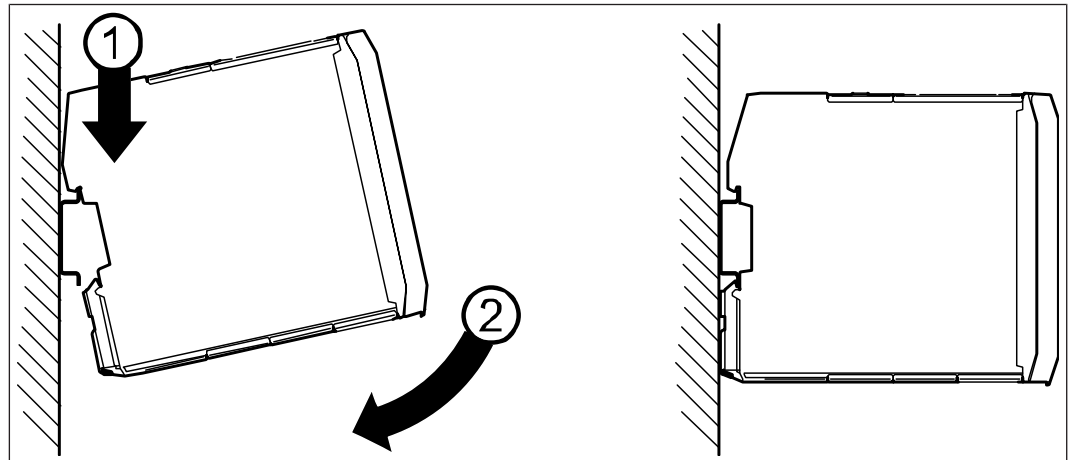

Fig. 13: Mounting on a mounting rail

- 1 Hook the housing groove from above onto the mounting rail.
- 2 Press the housing towards the mounting surface until the latch engages. Then check for tightness.

5.5.2 Disassembly of the mounting rail

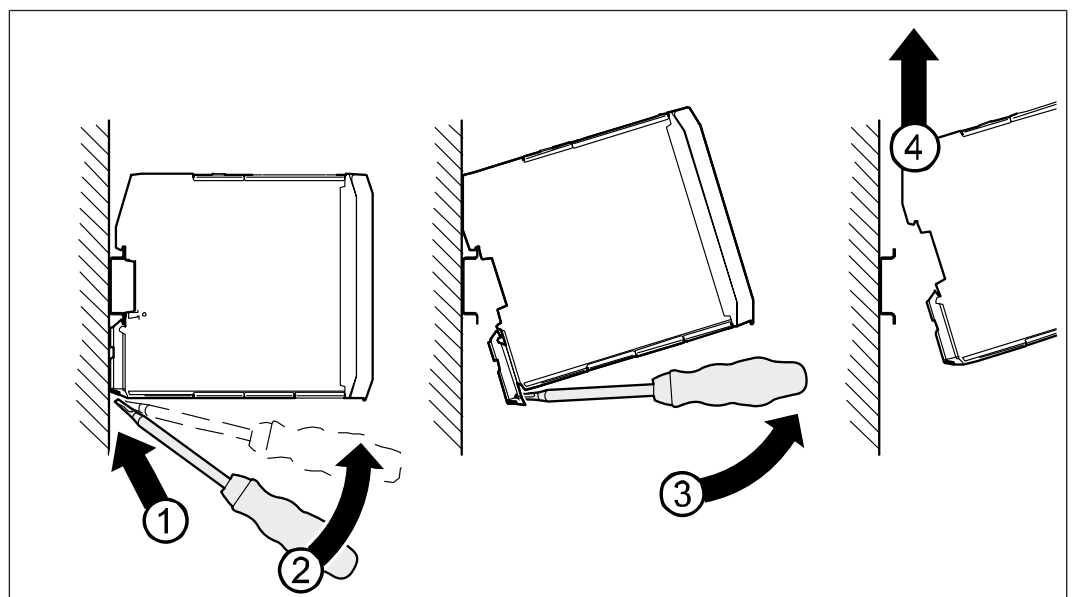

Fig. 14: Disassembly of the mounting rail

- 1 Insert screwdriver into the locking device.
- 2 Tilt the screwdriver towards the housing to release the locking device.
- 3 Tilt the device up with the released locking device.
- 4 Carefully lift the device upwards.

6 Electrical installation

- Lay control and power cables separately (approx. 10...20 cm distance).
- Lay power cable crossings at right angles.
- The following measures can be taken to prevent electromagnetic interferences:
 - Always connect the shielding with the greatest possible surface.
 - Position the shield as close as possible to the terminal.
 - Always use twisted and shielded cables for analog control cables. Connect shielding to source on one side only.
 - Twist digital control cables. Shielding may be required from 3 m. In this case, place on both sides.
- The device is protected against reverse polarity of the input voltage.
- The 24 V supply must not fall below or exceed the input voltage range specified in the technical data, independent of the operating conditions.
- If power interruptions need to be bridged, an external UPS must be used.

6.1 Assembly of wires

NOTICE

Loose and slack cable connections!

Malfunctions due to loose contacts.

- Observe metal sleeve length and stripping length according to table.
- Use a suitable pressing tool.
- Make sure that all wires are inserted into the wire-end sleeve.
- After inserting the cable into the terminal, check that it is firmly seated.

Cross section	Wire end ferrule	Metal sleeve length	Stripping length
0.5...1 mm ² (20...17 AWG)	With plastic collars	10 mm	12 mm
0.5...1,5 mm ² (20...16 AWG)	Without plastic collars	10 mm	10 mm
0.2...1.5 mm ² (24...16 AWG) Solid or fine strand	Without wire end ferrule	-	10 mm

Tab. 2: Wire end ferrules and stripping length

6.2 Voltage supply



Thanks to the device's internal protection with an eFuse, no voltage source with fourfold overload is required for line protection. A power source capable of driving the maximum input current of the device is sufficient.

NOTICE

Use of suitable voltage sources!
Electric Shock!

- a) Only voltage sources with safe extra-low voltage in accordance with HD 60364-4-41 may be used.
- b) Ensure that the used voltage supplies have the appropriate overvoltage category for the application.
- c) The requirements listed for SELV and PELV circuits in HD 60364-4-41 must be complied with.
- d) With existing or newly-wired circuits the person installing the device or machine must ensure that the PELV requirements are met.
- e) Connections with higher voltages must be excluded.

6.2.1 Terminal block X6

Voltage supply occurs via terminal block X6. Depending on the variant, a 4-, 8-, 12- or 16-pole pluggable terminal block is used.

X6	PIN	Designation	Notes
	1	24V	DC 24 V supply voltage (internally connected to pin 2)
	2	24V	DC 24 V supply voltage (internally connected to pin 1)
	3	0V	Reference potential to 24 V (internally connected to pin 4)
	4	0V	Reference potential zu 24 V (internally connected to pin 3)
	5-8	-	(⇒ CAN [▶ 31])
	9-12	-	(⇒ RS485 [▶ 33])
	13-16	-	(⇒ RS232 [▶ 34])
	1		
	2		

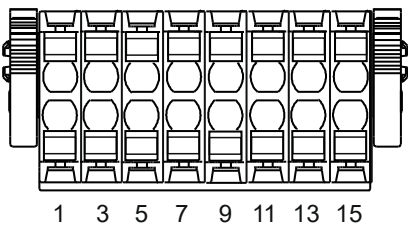
X6	PIN	Designation	Notes
			

Tab. 3: Assignment of terminal block X6

The terminals for the voltage supply are always identical, independent of the above design.

Notes

The connection terminals X6.1/X6.2 and X6.3/X6.4 are connected internally to create a daisy chain if required.

The 0 V terminals are **not** internally connected to earth.

The maximum permissible current via the terminal is 9.5 A and must not be exceeded.

The cables must be designed according to the current.

6.3 Earthing

A connection to the protective earth conductor is not required, because the device is operated with ELV (SELV/PELV)..

6.4 Equipotential bonding

The C6 Compact is designed to discharge EMC interference via the mounting rail.

This must therefore be connected to the functional equipotential bonding (can also be the

equipotential bonding). The following points must be observed:

- a) Good, large-surface connection from the mounting rail to the support (if it is conductive)
- b) Low-impedance connection of the support for potential equalisation (e.g. min. 4 mm² cable or ribbon cable)

Information on equipotential bonding conductors can be found at HD 60364-5-54!

6.5 EtherCAT Master X1

Specification	Fieldbus type	EtherCAT®
	Socket	X1 RJ45
	Transmission level	100Base-Tx according to IEEE802.3 with autonegotiation and auto-crossover
	Transmission speed	100 Mbit/s
	Transmission medium	Twisted Pair S-UTP; Cat. 5 maximum cable length 100 m
	Potential separation	Functional isolation to the control potential.

Connection

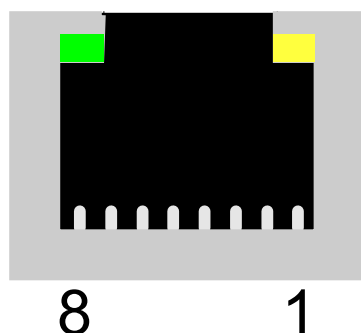

Fig. 15: RJ45 socket front view

PIN	RJ45 without supply voltage (Viewing with Auto-Cross Over)	
1	TX+	RX+
2	TX-	RX-
3	RX+	TX+
4	Reserved	
5	Reserved	
6	RX-	TX-
7	GND	
8	GND	

Tab. 4: PIN assignment RJ45 EtherCAT

LED / light pattern	Function
Yellow	without function
Green	Link/Activity
Off	Port closed
On	Port open; no data traffic
Flicker	Port open; with data traffic

Tab. 5: Function of the LEDs

6.6 Ethernet X2

Specification	Fieldbus type	Ethernet
	Socket	X2 RJ45
	Transmission level	100Base-Tx according to IEEE802.3 with autonegotiation and auto-crossover
	Transmission speed	10/100 Mbit/s
	Transmission medium	Twisted Pair S-UTP; Cat. 5 maximum cable length 100 m
	Potential separation	Functional isolation to the control potential.

Connection

PIN	RJ45 without supply voltage (Viewing with Auto-Cross Over)	
1	TX+	RX+
2	TX-	RX-
3	RX+	TX+
4	reserved	
5	reserved	

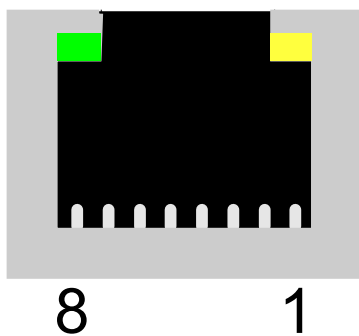

Fig. 16: RJ45 socket front view

PIN	RJ45 without supply voltage (Viewing with Auto-Cross Over)	
	6	RX-
7	GND	
8	GND	

Tab. 6: PIN assignment RJ45 Ethernet

LED / light pattern	Function
Yellow (flashing)	Port available
Green	Link/Activity
Off	Port closed or not connected
On	Port opened; no data traffic
Flickering	Port opened; with data traffic

Tab. 7: Function of the LEDs

6.7 Ethernet X3

Specification

Fieldbus type	Ethernet
Socket	X3 RJ45
Transmission level	1000Base-Tx according to IEEE802.3 with autonegotiation and auto-crossover
Transmission speed	10/100/1000 Mbit/s
Transmission medium	Twisted Pair S-UTP; Cat. 6 maximum cable length 100 m
Potential separation	Functional isolation to the control potential.

Connection

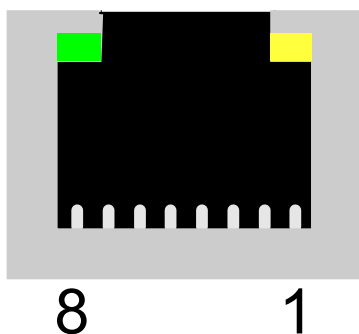

Fig. 17: RJ45 socket front view

PIN	RJ45 without supply voltage (Viewing with Auto-Cross Over)	
	1	TX+
2	TX-	RX-
3	RX+	TX+
4	reserved	
5	reserved	
6	RX-	TX-
7	GND	
8	GND	

Tab. 8: PIN assignment RJ45 Ethernet

LED / light pattern	Function
Yellow (flashing)	Port available
Green	Link/Activity
Off	Port closed or not connected
On	Port opened; no data traffic
Flickering	Port opened; with data traffic

Tab. 9: Function of the LEDs

6.8 CAN

The CAN bus is connected via terminal block X6. Depending on the variant, an 8, 12 or 16-pole plug-in terminal block is used.

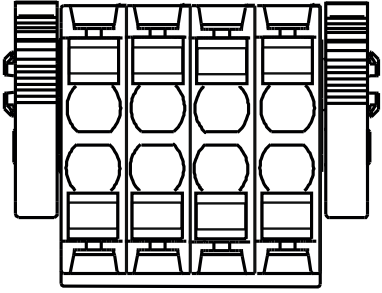
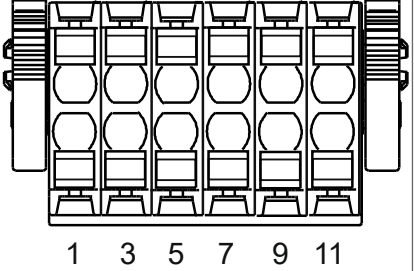
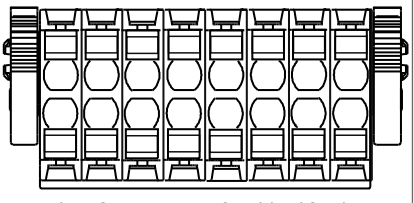
X6	PIN	Designation	Notes	
	1-4	-	Voltage supply	
	5	Shielding	Shield connection (FE)	
	6	CAN_GND	Reference potential CAN (galvanically isolated)	
	7	CAN_H	CAN data signal high	
	8	CAN_L	CAN data signal Low	
	9-12	-	(⇒ RS485 [33])	
		13-16	-	(⇒ RS232 [34])
				

Tab. 10: Assignment of terminal block X6

The terminals for the CAN bus are always identical, independent of the above design.

Specification

Fieldbus type

CAN

Transmission level

In accordance with DIN ISO 11898; ISO High Speed

Transmission speed

20, 25, 50, 100, 125, 250, 500, 800, 1000 kbit/s; adjustable via CN01

Transmission medium

Twisted pair
maximum cable length 40 m

Potential separation

Functional isolation between CAN terminals and control potential.

Bus termination

120 Ω external between (CAN High and CAN Low) at both ends of the bus cable.

Connection

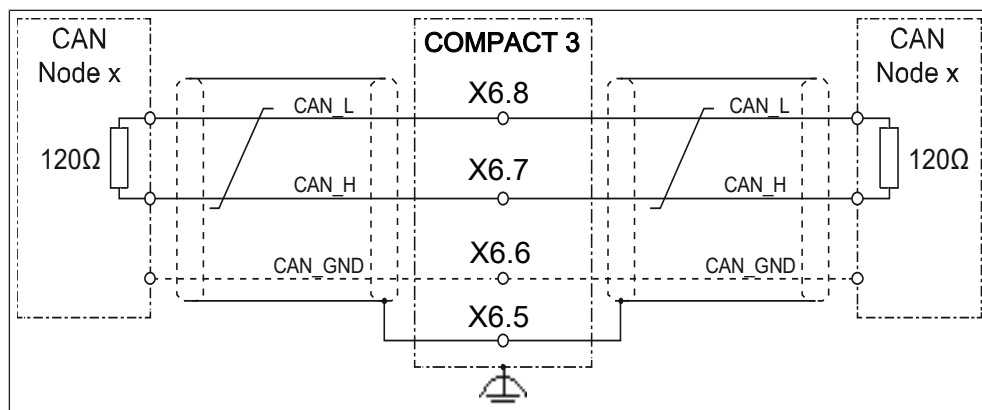

Fig. 18: Connection CAN bus

Terminal X6	Designation	Note
5	Shielding	Total shield
6	CAN GND	CAN ground (can be wired depending on the customer participant)
7	CAN High	Data cable CAN_H and CAN_L twisted;
8	CAN Low	no internal bus termination

see also

📄 Terminal block X6 [► 27]

6.9 RS485

The RS485 interface is connected via the X6 terminal block. Depending on the variant, a 12- or 16-pole pluggable terminal block is used.

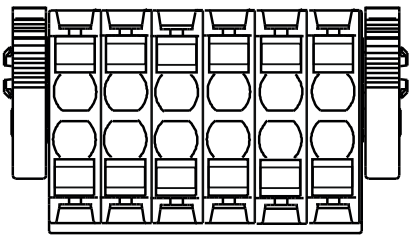
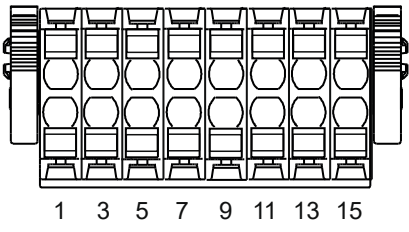
X6	PIN	Designation	Notes
	1-4	-	(⇒ Voltage supply [▶ 27])
	5-8	-	(⇒ CAN [▶ 31])
	9	VCC+5V	Termination potential for RS485
	10	GND_RS	Reference potential for serial interfaces (galvanically isolated)
	11	RxD/TxD-P	RS485 data signal
	12	RxD/TxD-N	RS485 data signal inverted
	13-16	-	(⇒ RS232 [▶ 34]) interface

Tab. 11: Assignment of terminal block X6

The terminals for the RS485 interface are always identical, independent of the above design.

Specification

Fieldbus type	RS485 2W
Common-ode voltage range	0... 12 V to the reference potential.
Transmission speed	20, 25, 50, 100, 125, 250 kbit/s; adjustable via CN01
Transmission medium	Twisted pair maximum cable length 1200 m depending on the transmission speed
Potential separation	Functional insulation between terminals and device potential.
Bus termination	120 Ω external (between RxD/TxD-P and RxD/TxD-N) at both ends of the bus cable.

6.10 RS232

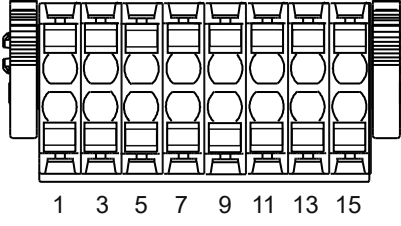
X6	PIN	Designation	Notes
	1-4	-	Voltage supply
	5-8	-	(⇒ CAN [▶ 31])
	9, 11, 12	-	RS485
	10	GND_RS	Reference potential for serial interfaces (galvanically isolated)
	13	RxD	RS232 receive signal
	14	TxD	RS232 transmission signal
	15	CTS	Ready to receive (clear to send)
	16	RTS	Ready to send (request to send)

Tab. 12: Assignment of terminal block X6

6.11 INTERBUS interface X10, X11

Optionally, the C6 COMPACT 3 can be ordered with an INTERBUS slave interface. The word and size parameters are configured via DIP switch S1.

Input:

D-SUB DE-9 (socket)

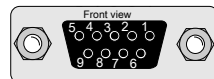

Fig. 19: X10 INTERBUS input

1 DO (Data Out)	2 DI (Data In)
3 COM (signal ground)	4 - (reserved)
5 - (reserved)	6 /DO (Data Out inverted)
7 /DI (Data In inverted)	8 - (reserved)
9 - (reserved)	

Output

D-SUB DE-9 (connector)

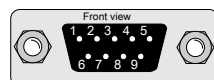
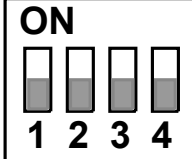

Fig. 20: X11 INTERBUS output

1 DO (Data Out)	2 DI (Data In)
3 COM (signal ground)	4 - (reserved)
5 - (reserved)	6 /DO (Data Out inverted)
7 /DI (Data In inverted)	8 - (reserved)
9 - (reserved)	

6.11.1 INTERBUS DIP switch S1

	<p>SW1 - SW4 Individually programmable in the IEC programme.</p>
---	---

Tab. 13: DIP switch 4-fold

6.11.2 INTERBUS remote bus cable

Specification

Number of conductors	3x 2-pair (twisted) with overall shielding
Conductor cross-section	min. 0.2 mm ²
Conductor resistance per 100 m	max. 9.6 Ω

Tab. 14: Specification INTERBUS remote bus cable

Further specifications can be found in the cable manufacturer's data sheet.

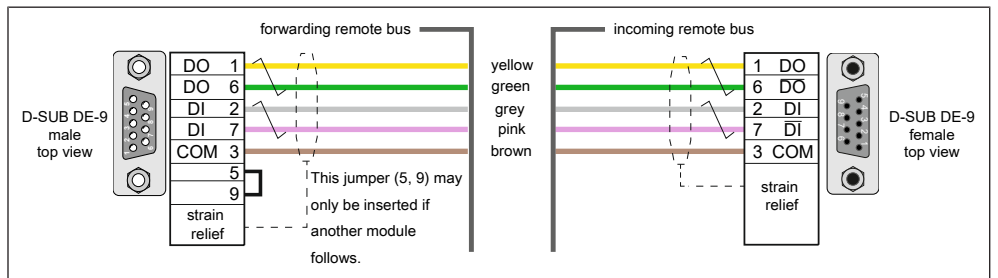

Fig. 21: INTERBUS remote bus cable assignment

6.11.3 INTERBUS extension

The INTERBUS interface of the C6 Compact 3 is implemented through a combination of several software components:

- INTERBUS firmware
- CODESYS© KEB INTERBUS component
- IEC programme (sample programme available, provision and commissioning on request)

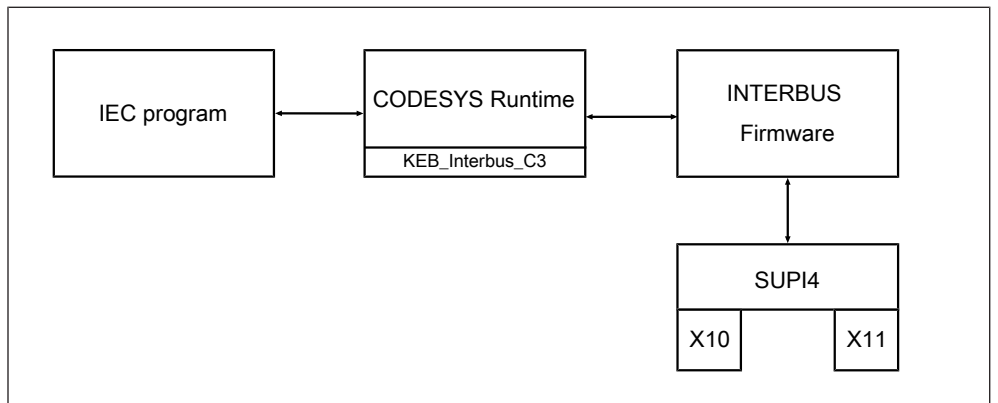

Fig. 22: Software structure INTERBUS extension

Software component	Description
INTERBUS firmware	Communication with SUPI4. Reading and writing process data (PDO) and parameterisation data (PCP) from the SUPI. Configuration of the SUPI4 protocol chip via object directory (CFG) by the user via the IEC programme.
KEB INTERBUS CoDeSys component	External Codesys library. Communication with INTERBUS firmware. Provision of INTERBUS access functions for IEC programme. Not for the user.
IEC program	IEC program. Calling the INTERBUS access functions using the KEB_Interbus_C3 library. IEC object directory for PCP. User program. INTEBRUS sample IEC programme available on request. Demonstrates how to call the INTERBUS access functions.

Tab. 15: Software components of the INTERBUS extension

6.11.3.1 Data channels

The INTERBUS extension has three channels available to the user. The use of all three channels is demonstrated in the IEC INTERBUS sample project.

Process data channel (PDO)

Data channel for cyclic process data. Receiving PDIN data and sending PDOOUT data by calling an IEC function block of type `IbsC3PdoHandler`.

The process data length is set via the parameter `pd length` and is a maximum of 62 bytes (see parameters for the INTERBUS connection).

Parameterisation channel (PCP)

INTERBUS parameterisation channel. To use the PCP channel, an object directory must be created in the IEC program. This object directory can be accessed via PCP using a function block of type `KebChannelHandler` in conjunction with a function block of type `IbsC3PcpHandler`.

Configuration channel (CFG)

INTERBUS configuration channel for reading and writing the object directory of the INTERBUS firmware. This displays the status and configuration of the SUPI4 protocol chip.

Similar to the use of the parameterisation channel (PCP), the object directory is accessed via a function block of the type `KebChannelHandler` in conjunction with a function block of the type `IbsC3CfgHandler`.

Alternatively, the parameters can also be read and written with COMBIVIS via an IEC-DIN66019 slave of type `Din_Slave_Udp`. This must also be registered with the function block of type `KebChannelHandler`.

6.11.3.2 Parameters of the INTERBUS connection

Name	password
Significance	Set password level to write parameters.
Index	2001h
Sub-index	0

Data length	4 bytes
Coding	100: cp_ro 440: application
Access	Read_Write
Standard	0
Note	

Name	pd length
Significance	INTERBUS process data length in bytes.
Index	2002h
Sub-index	0
Data length	2 bytes
Coding	0: 0 byte 2: 2-byte 4: 4-byte 6: 6-byte 8: 8-byte 10: 16-byte 12: 12-byte 14: 14 Byte 16: 16-byte 18: 18-byte 22: 22 bytes 26:26 bytes 30: 30 bytes 46: 46 bytes 50: 50 bytes e 62: 62 bytes
Access	Read_Write
Standard	8
Note	

Name	Bus speed
Significance	INTERBUS bus speed.
Index	2003h
Sub-index	0
Data length	4 bytes
Coding	0: 500 kBaud/s 1: 2 Mbaud/s 2: 8 MBaud/s 3: Mbaud/s 255: autodetect
Access	Read_Write
Standard	255
Note	

Name	Bus state
Significance	INTERBUS bus state.

Index	2004
Sub-index	0
Data length	2 bytes
Coding	2: reset 4: check sequence 8: active 16: Remote bus disabled 32: crc error 64: crc status
Access	Read
Standard	0
Note	

6.11.3.3 Object directory of the IEC program (PCP)

The object directory in the IEC programme for PCP access must be filled in by the user. This case is demonstrated in the sample project.

7 Operation

7.1 Status displays

A total of 6 LEDs are available to display the status.

The following LEDs show the system status:

SYS for general system states of the device

PLC for the CODESYS application (RUN / STOP / ERROR)

APP for the states of the microservices

SD for access to the MicroSD

2 (3) LEDs are available for function extensions (fieldbus-specific)

LD5 for Interbus slave or other fieldbuses

BUS for EtherCAT master or freely available

Flashing pattern of the LEDs

SYS LED flashing pattern during boot process

Colour/ flashing pattern	Type	Code	Message	Description
red / static	Info	-	-	Supply voltage is present. Kernel not yet booted.
red / static	Error	E-SYS4	Boot error	Kernel could not be started within 10 s.
yellow / flashing	Info	I-SYS4	System start	System is booted.
off	-	-	-	No voltage supply

Tab. 16: SYS LED flashing pattern during boot process

Flashing pattern SYS LED in operation

Colour/ flashing pattern	Type	Code	Message	Description
green / static	Info	I-SYS1	System is running	System is running. No error reported.
red / flashing	Error	E-SYS2	Operating system error	System error occurred.
red / yellow flashing	Warn- ing	W-SYS1	System update in progress	Do not switch off the device!
yellow / static	Warn- ing	W-SYS2	System warning	With error output, e.g. memory almost full.
green / yellow flashing	Info	I-SYS3	Wink function	The Wink function has been activated in the System Manager. The device can be localised via the flashing LED.

Tab. 17: Flashing pattern SYS LED in operation

Flashing pattern PLC LED

Colour/ flashing pattern	Type	Code	Message	Description
green / static	Info	I-PLC1	CODESYS applic- ation is running	The CODESYS application is fully loaded and is running.
red / static	Error	E-PLC1	CODESYS applic- ation is stopped	The CODESYS application is not running.
red / flashing	Error	E-PLC2	Licence errors	Application stopped due to licence error.

Tab. 18: Flashing pattern PLC LED

Flashing pattern APP LED

Colour/ flashing pattern	Type	Code	Message	Description
green / static	Info	I-APP1	Application is run- ning	App Manager does not report any applications with errors.
yellow / static	Warn- ing	W-APP1	Some applications have been stopped	Check in the App Manager.
red / static	Error	E-APP1	Application error	The App Manager has reported an error.
red / yellow flashing	Info	I-APP2	Applications are updated	The App Manager is busy.

Tab. 19: Flashing pattern APP LED

Flashing pattern SD LED

Colour/ flashing pattern	Type	Code	Message	Description
yellow / pulsat- ing	Info	-	SD activity	Read/write access to the SD card.

Tab. 20: Flashing pattern SD LED

Flashing pattern LD5 LED

Colour/ flashing pattern	Type	Code	Message	Description
red / static	Error	E-IBS1	Fieldbus error	Error in the INTERBUS slave.

Tab. 21: Flashing pattern LD5 LED (USER mode)

Flashing pattern BUS LED

Colour/ flashing pattern	Type	Code	Message	Description
red / static	Error	E-BUS1	Fieldbus error	Error on the EtherCAT bus.
green / static	Info	-	Bus running	Bus does not report any errors.

Tab. 22: Flashing pattern BUS LED

7.2 Start-up

7.2.1 Requirements for start-up

To start-up the COMPACT 3, the following minimum requirements apply to the browser:

IDE	HMI	Mobile
Google Chrome from version 106	Google Chrome from version 106	Google Chrome (Android) from version 113
Microsoft Edge from version 106	Microsoft Edge from version 106	Safari (iOS) from version 16
	Safari (macOS) from version 16	

Tab. 23: Browser depending on the device

7.2.2 Find COMPACT 3 in the network

If only one COMPACT 3 is available in the same network segment, it can be found using the ping command.

To do this, the following command is typed into the command line interpreter:

```
ping c6c3 -4
```

the following result should appear:

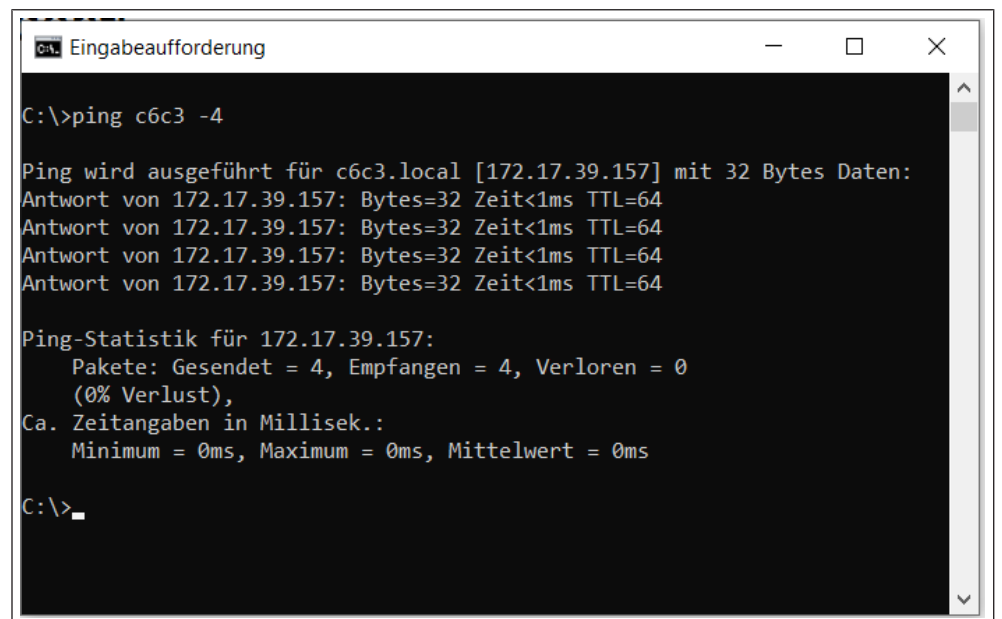

Fig. 23: find IP address

Alternatively, an IP scanner can be used to search for devices.

7.2.2.1 Link-Local Addressing

Link-local addressing enables devices in the same local network segment to communicate without requiring a DHCP server.

IPv4 uses the range 169.254.x.x

IPv6 uses the range fe80::/10.

If a device is set to automatic addressing, it assigns itself a link-local address if no IP is configured.

Example of a P2P connection:

- **C6 device (port x2):** Automatically assigns 169.254.1.1.
- **Windows PC network adapter (Automatic/APIPA):** Automatically assigns 169.254.1.2.
- Both devices can communicate directly via these addresses without additional network configuration.

7.2.2.2 Avahi hostname resolution

Avahi provides configuration-free network discovery and hostname resolution using the mDNS (multicast DNS) protocol. This allows devices on the same local network to communicate using readable host names instead of IP addresses without a DNS server. Host names are automatically supplemented with ".local".

Example of a P2P connection:

- **C6 device (port x2):** Full hostname c6c3.local
- **Windows PC:** Can resolve c6c3.local using an mDNS client (e.g. Bonjour for Windows)
- Communication is possible without manually entering IP addresses; the host name automatically maps to the link-local IP of the device.

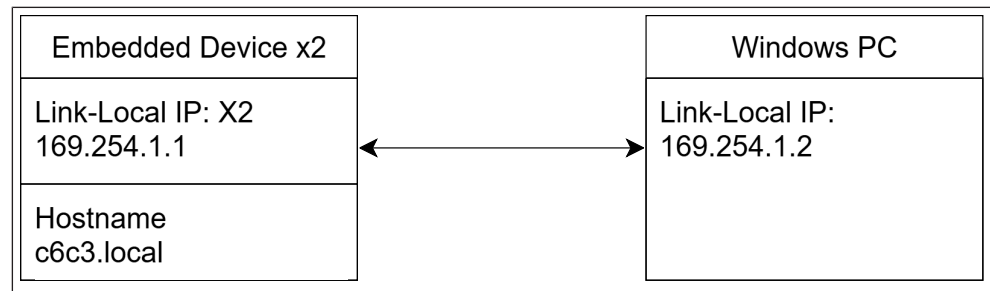

Fig. 24: Peer-to-peer connection

If several devices with the same hostname are located in the same network, the Avahi hostname is incremented dynamically:

Device 1: c6c3.local

Device 2: c6c3-2.local

Device 3: c6c3-3.local

7.2.2.3 Initialisation of communication

1. **Link-local addressing:**
Both devices automatically assign themselves an IP address in the range 169.254.x.x, as no DHCP server is available. This allows direct communication.
2. **Avahi (mDNS) hostname resolution:**
 - The embedded device announces its host name c6c3.local via the local connection.
 - The Windows PC can resolve c6c3.local to 169.254.1.1 using an mDNS client (e.g. Bonjour).
3. **Result:**
The devices can communicate directly with each other without manual IP configuration, either via the IP address (169.254.1.1) or the host name (c6c3.local).

7.2.3 Starting the web interface

The operation is carried out with the web interface NOA UI Hub via the web browser.

The NOA UI Hub can be accessed as follows:

With the IP address of the COMPACT 3 via port 8515 (e.g:
172.168.2.151:8515)

With access via local hostname link (( <http://c6c3.local:8515>))

With access via host name (( <http://c6c3:8515>))

Then the NOA UI Hub appears with the currently installed apps.



Fig. 25: Starting the NOA UI Hub

The respective app can now be opened by clicking on the tile or via the menu in the top left-hand corner.

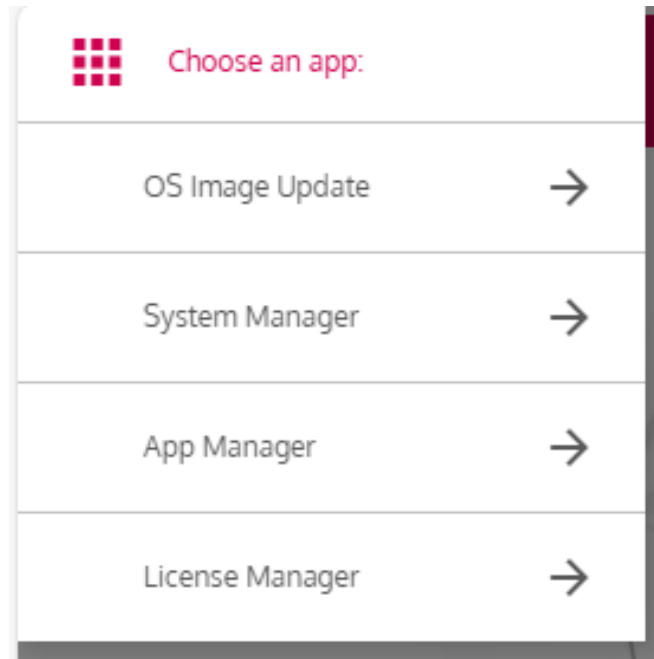

Fig. 26: Select the app and start

7.2.4 Login

After entering the IP address and port, the login screen appears.

To log in, enter the following user data:

User name: `service`

Password: `kebadmin`

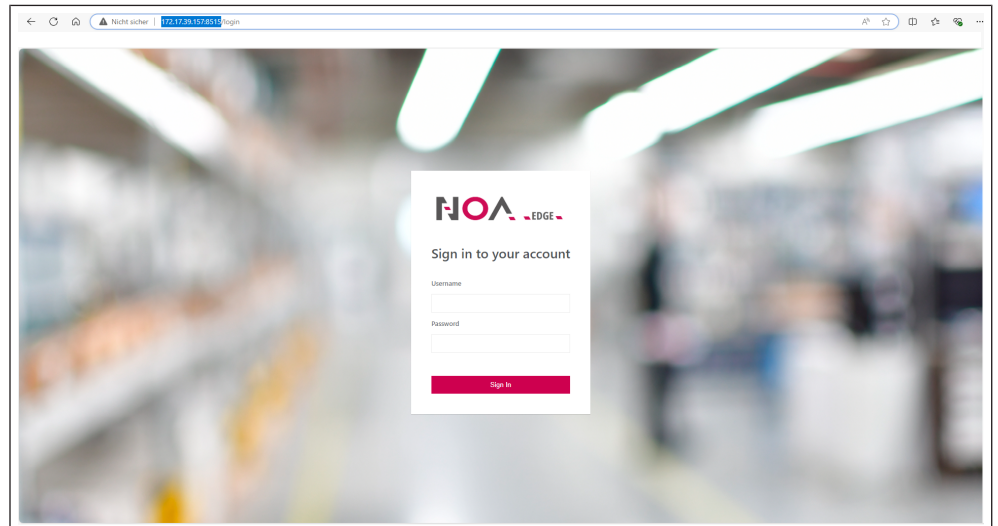

Fig. 27: Login NOA Edge

7.2.5 Logout

If no entries are made for 10 minutes, the user is automatically logged out.

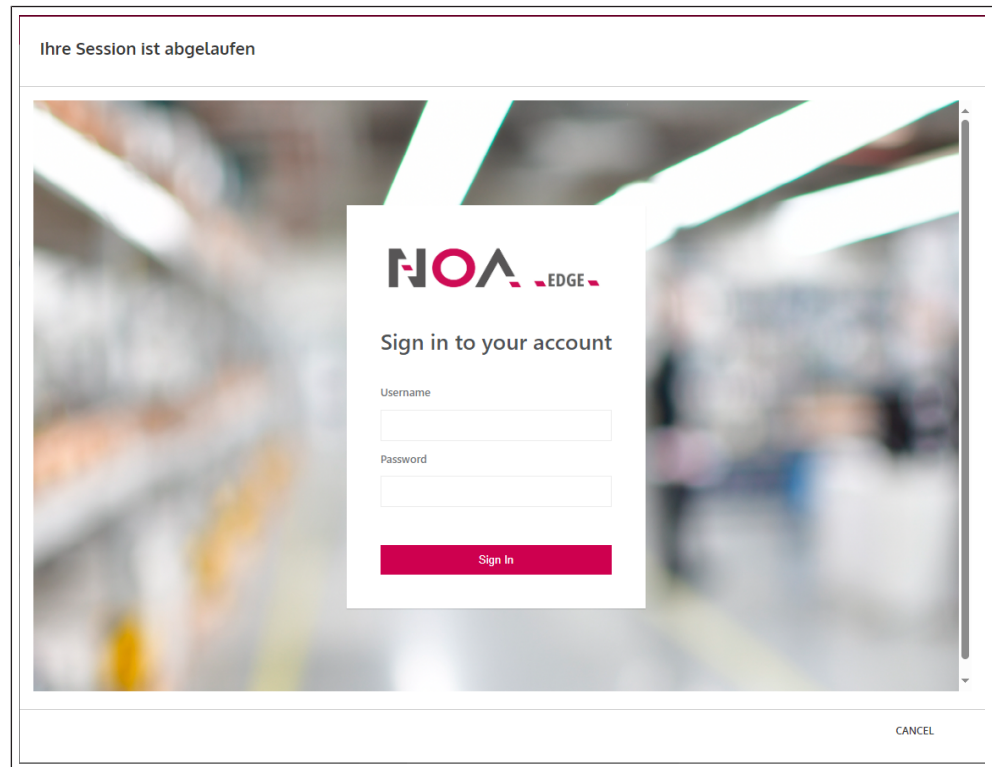

Fig. 28: Automatic logout

You can log in again by entering your username and password.

7.3 System Manager

7.3.1 Overview

The overview shows all information on the selected COMPACT 3. By clicking on the button **Wink**, the status LED "SYS" flashes to identify the selected COMPACT 3 in the control cabinet.

Click on the **Restart** button in the operating system field to restart the COMPACT 3.

An encrypted network connection is activated with the switch **SSH access**.

CAUTION! Expert setting! Changes to the device via SSH can have a negative impact on the device function. Only use this access in a secure environment. For security reasons, access is closed again 5 minutes after the next restart.

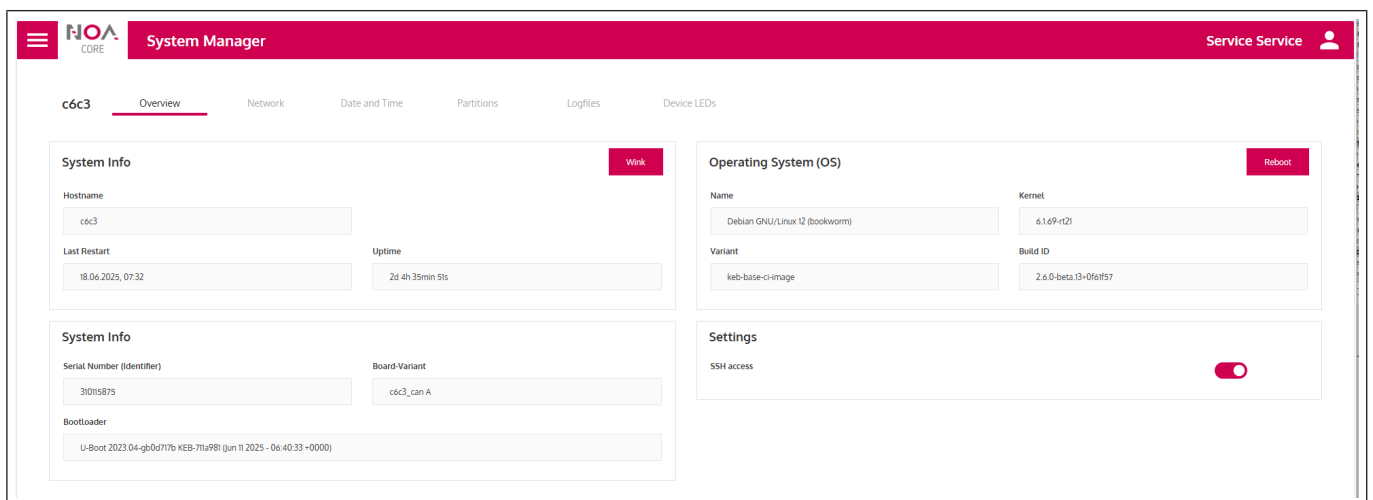

Fig. 29: System Manager overview

7.3.2 Network

- Hostname - Name of the control in the network. The pen can be used to change the host name.
- X1, X2, X3 – Settings of the respective interface.
- Manual IP assignment. With this switch, the IP address is no longer assigned automatically via the DHCP server. The settings below can be specified manually.
Attention! A changed IP address becomes active with **Activate now**. The system manager is now no longer connected to the control. It must be restarted with the new IP address.
- **Save** saves the settings statically. These are always activated when the system is restarted.

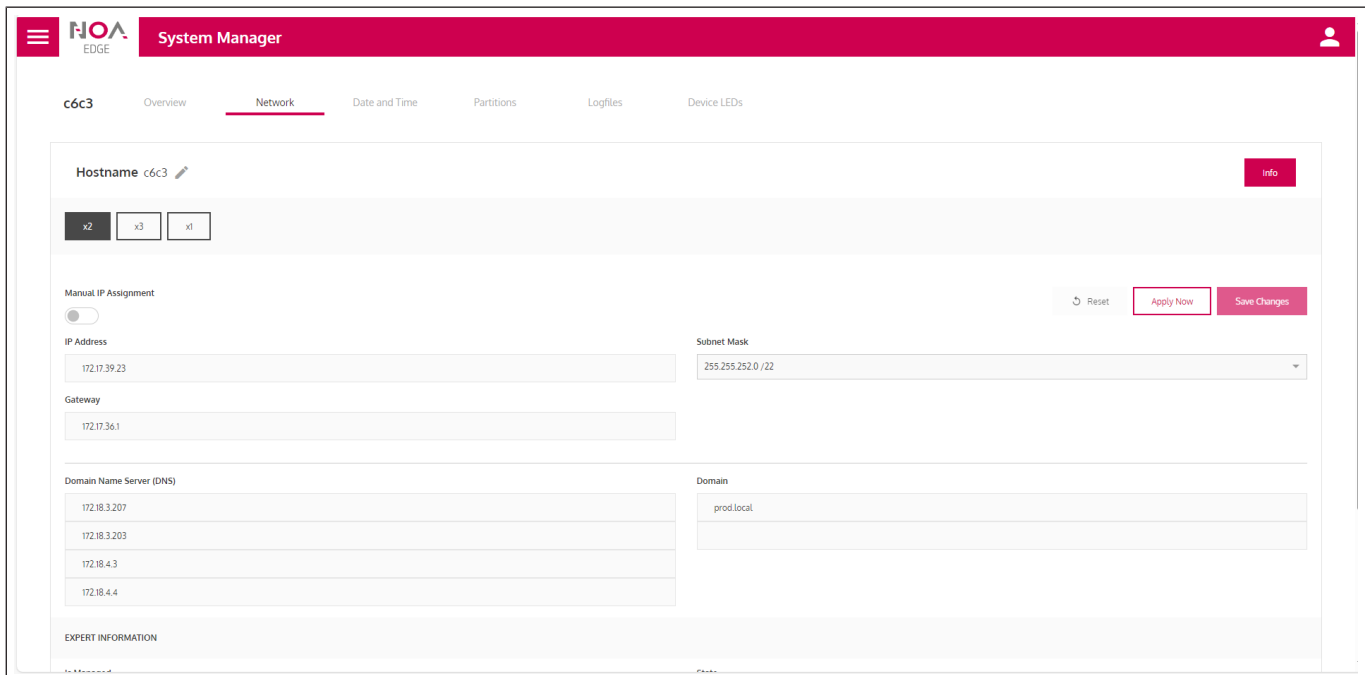

Fig. 30: System Manager - Network

7.3.3 Date and time

Switch **Manual date and time**:

- Off - Date and time are obtained automatically via the network.
- On - Date, time and time zone can be set manually.

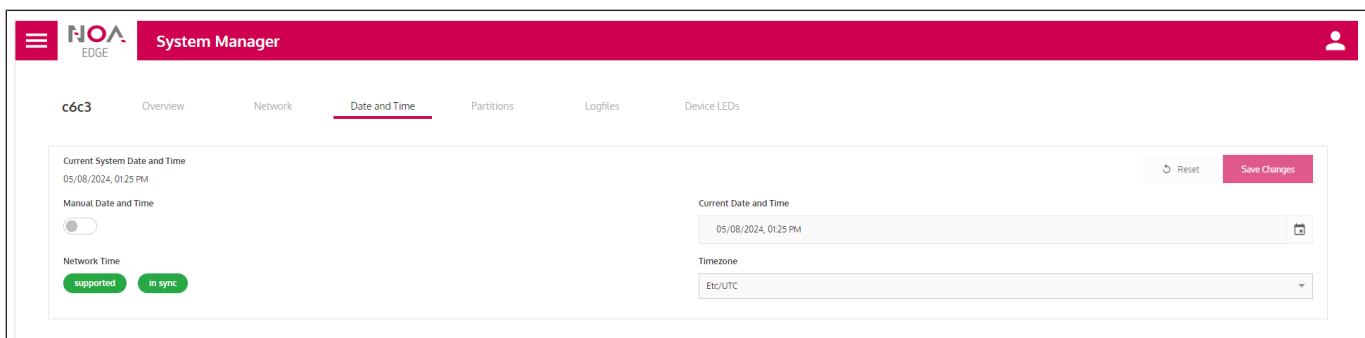

Fig. 31: System Manager date and time

7.3.4 Partitions

Display of the partitions created on the COMPACT 3.

Name	Mount Point	Type	Size Total	Size Free	Size Used	Size Used Percent
/dev/mmcblk1p6	/app/sharedData	ext2/ext3	28313595904	27286994944	438329344	1
/dev/mmcblk1p2	/etc/localtime.ro	ext2/ext3	1521885184	667017216	757563392	53
/dev/mmcblk1p5	/var/log	ext2/ext3	61820928	54448128	2678784	4
/dev/mmcblk1p6	/etc/resolv.conf	ext2/ext3	28313595904	27286994944	438329344	1
/dev/mmcblk1p6	/etc/hostname	ext2/ext3	28313595904	27286994944	438329344	1
/dev/mmcblk1p6	/etc/hosts	ext2/ext3	28313595904	27286994944	438329344	1

Fig. 32: System Manager - Partitions

7.3.5 Log files

Display of the different log files. Click on ⋮ for further options regarding the log file.

Name	Change Date	Size	Is Dir
README	2024-01-26T21:48:52.454Z	39	false
auth.log	2024-05-08T08:42:12.34357528Z	29402	false
auth.log.1	2024-05-04T08:37:58.20695826Z	39225	false
btmtp	2024-05-08T08:42:10.861562447Z	2000	false
btmtp.1	2024-01-26T21:48:52.496Z	0	false
chrony	2024-01-26T21:48:57.513Z	4096	false
kern.log	2024-05-08T11:02:51.318927105Z	259656	false
kern.log.1	2024-05-02T13:25:53.569751083Z	337506	false
lastlog	2024-05-06T11:34:25.766621731Z	296296	false
lost+found	2024-04-24T12:08:49Z	16384	false
private	2024-05-06T12:10:05.112266249Z	4096	false
evsel.log	2024-05-08T11:06:38.065027301Z	701047	false

Fig. 33: System Manager - Log-files

7.3.6 Device LEDs

The status of the device LEDs is displayed here, analog to the device. (⇒ [Status displays \[▶ 39\]](#)).

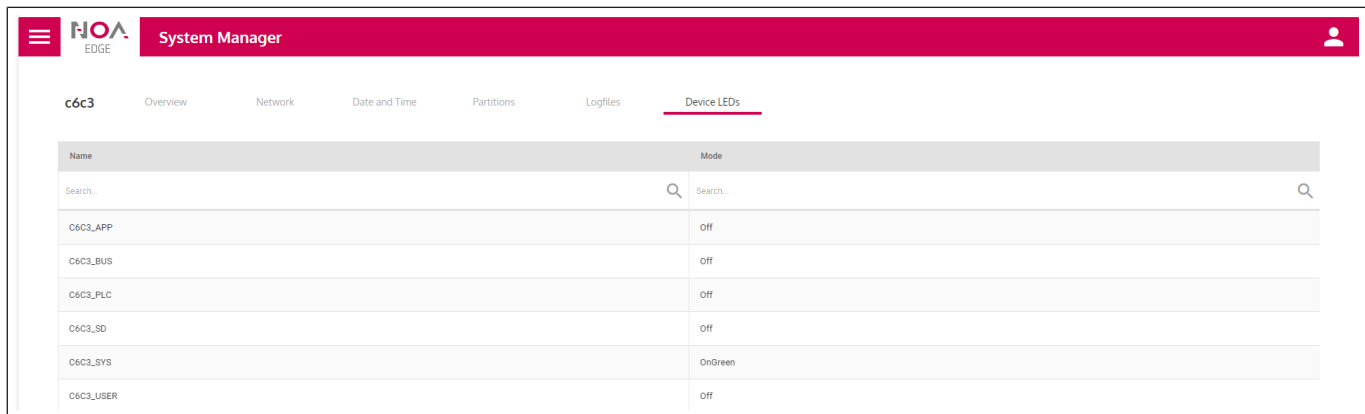

Name	Mode
Search...	Search...
C6C3_APP	off
C6C3_BUS	off
C6C3_PLC	off
C6C3_SD	off
C6C3_SYS	OnGreen
C6C3_USER	off

Fig. 34: System Manager - Device LEDs

7.4 Licence Manager

7.4.1 My licences

The currently installed licenses are displayed here. Additional licenses can be added using the “+ Add License” button.

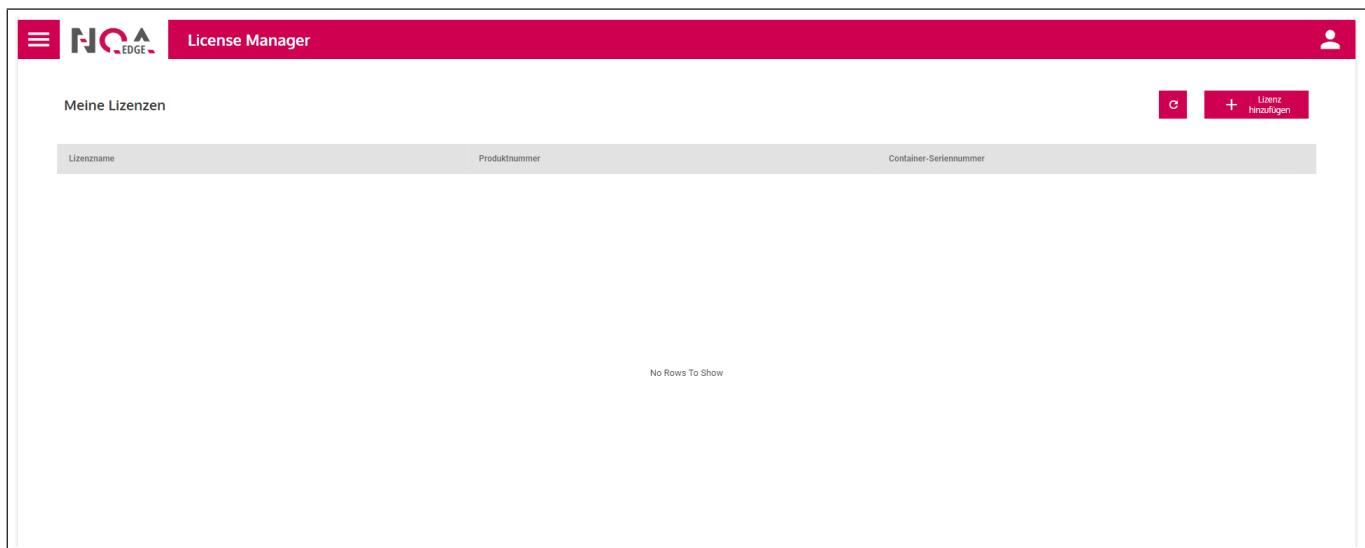

Lizenzname	Produktnummer	Container-Seriensummer
No Rows To Show		

Fig. 35: Licence Manager - My licences

7.5 App Manager

⚠ DANGER



Installing, updating or deleting apps during operation.

This can lead to undefined system states and poses an immediate danger to the operator and the plant.

✓ Before you start work:

- a) Shut down connected machines in a controlled manner.
- b) Set the control system to a safe operating state.
- c) Now you can start installing, updating or deleting apps.

7.5.1 Installed apps

The App Manager is used to display the installed apps. The status, current version and any available updates for the respective apps are also displayed.

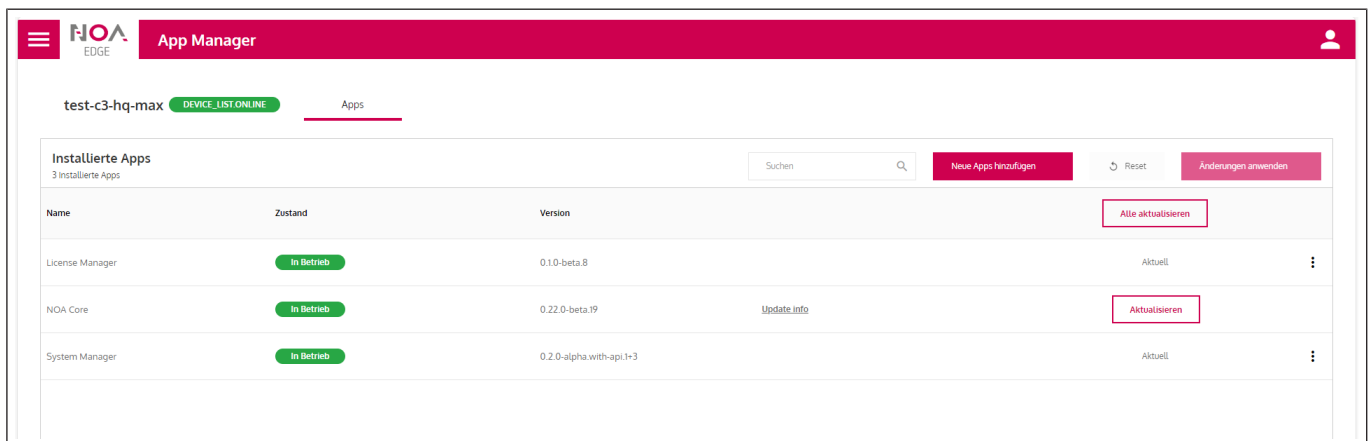

Fig. 36: App Manager - Installed apps

7.5.1.1 Install apps

Click on **Add new apps** to open a catalog with the available apps.

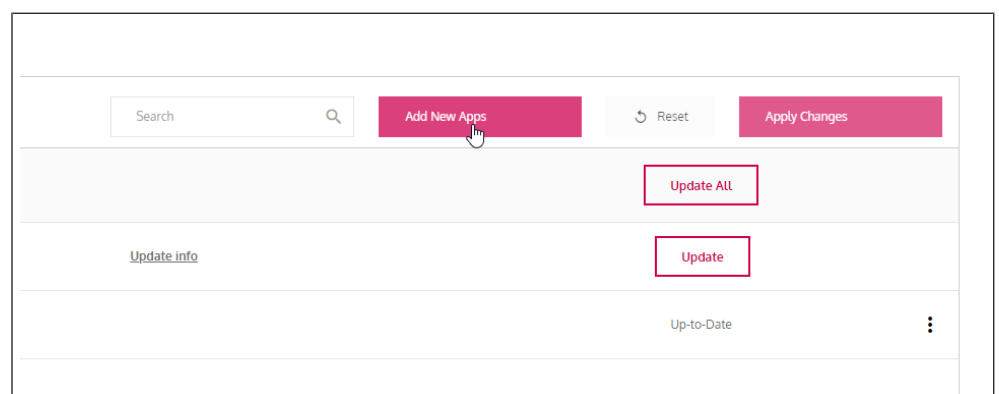

Fig. 37: Open the app catalog

By clicking on Add, one or more apps can be selected for installation. Click the Finished button to confirm the selection.

Click on **Apply changes** to install the app(s).

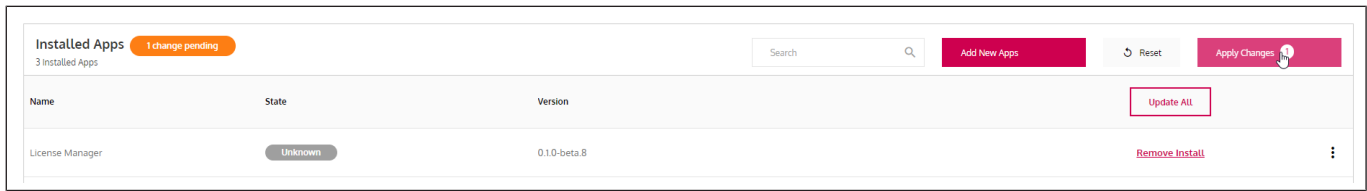

Fig. 38: Start installation of new apps

7.5.1.2 Delete apps

Apps are deleted in two steps:

- Mark the app(s) to be deleted.

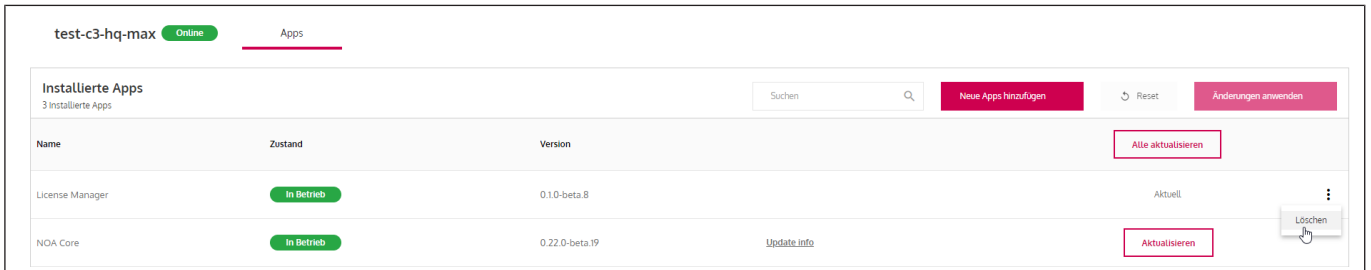

Fig. 39: Mark the app to be deleted

The number of selected apps is displayed in the button **Apply changes**.

- Delete
Clicking on the button **Apply changes** starts the deletion.

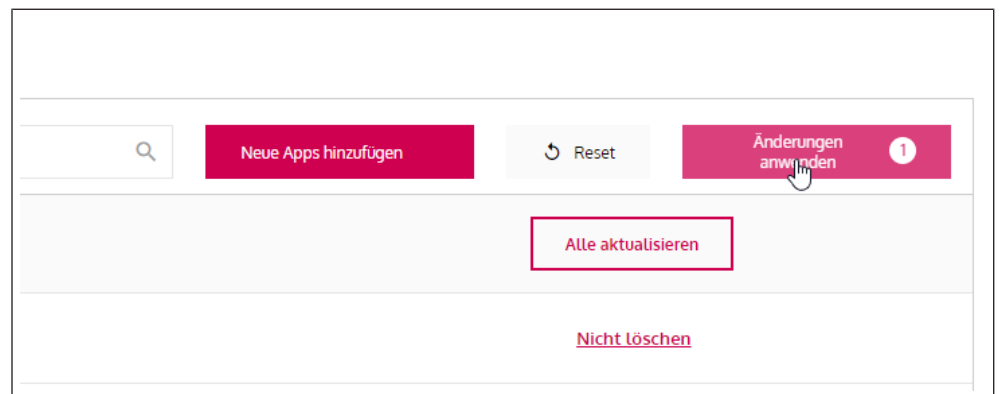

Fig. 40: Delete apps

7.6 OS and bootloader update

Preparation:

- ✓ Download the desired device update bundle (C6 COMPACT 3 Image x.x.x. + Bootloader.zip) from (🌐) ► <https://keb-automation.com/compact3>.
 - ✓ Unpack the ZIP file.
 - ✓ Ensure that the power supply is not interrupted during the update.
 - ✓ Stop all machine functions before the update.
- a) Start the "OS Image Update" app via the tile on the web interface or from the system menu.

7.6.1 OS Image update

Info! The device provides an A/B update mechanism for the device software. The inactive partition is updated in the background and only becomes active after the automatic restart.

This does not apply to the bootloader. Particular attention must be paid here to a safe power supply.

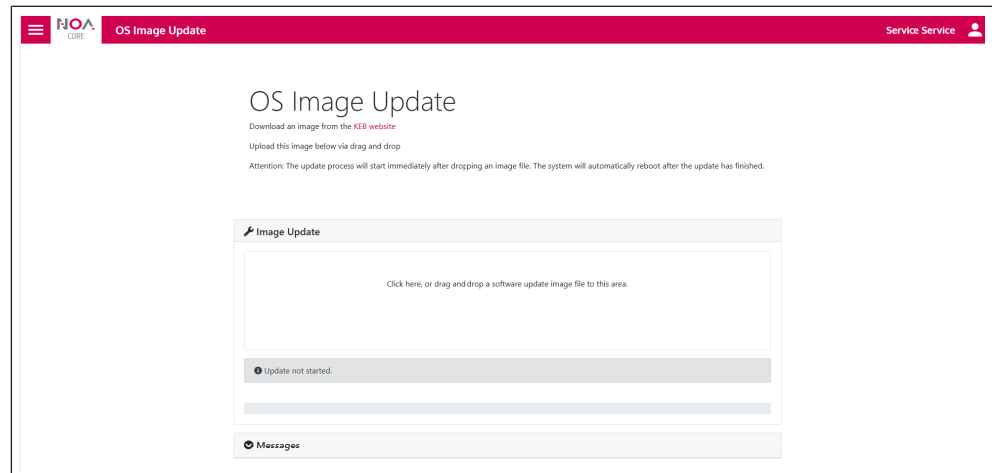

Fig. 41: OS Image Update

- After unzipping the zip file, two files are available for the update:
 keb-base-image-debian-bookworm-compact-v3-xxxxx.swu
 keb-base-image-debian-bookworm-compact-v3-u-boot-xxxxx.swu
- To start the update, first drag the device update bundle (.swu) with the suffix "u-boot" into the designated area.
- The update starts immediately after the device update bundle has been stored.
- After the update is complete, the system automatically reboots.
- Then repeat the process with the second file.

7.7 SD card handling

This function is integrated from software version 2.7 onwards.

The following section explains how to use an SD card to manage the network settings of the C6 COMPACT 3 system.

Functions:

- Backup: Automatically saves the current network settings and information to the SD card.
- Restore/Apply: Enables new network settings to be applied from the SD card.
- Logging: Stores logs for troubleshooting purposes.

Warning

- All new network settings found on the SD card will be applied immediately.
- Do NOT use this function while the device is in operation or during critical operations, as the network connection may change without further confirmation.
- Do not remove the SD card during the process (SD LED indicates activity) to avoid damaging the files.

7.7.1 Preparing the SD card

1. Format the SD card (recommended: FAT32 or ext4 for Linux workstations).
2. Create the following folder structure on the SD card:
 - /newSettings/NetworkManager/system-connections/
3. Add your network configuration files to the "system-connections" folder.
 - Use the sample connection files provided below as a reference.
 - Ensure that the files for NetworkManager are correctly formatted (see <https://networkmanager.dev/docs/api/latest/nm-settings-keyfile.html>).

- Use x1, x2, x3 as file names, "id" as field names, and as interface names.

7.7.2 Overview of folder structure

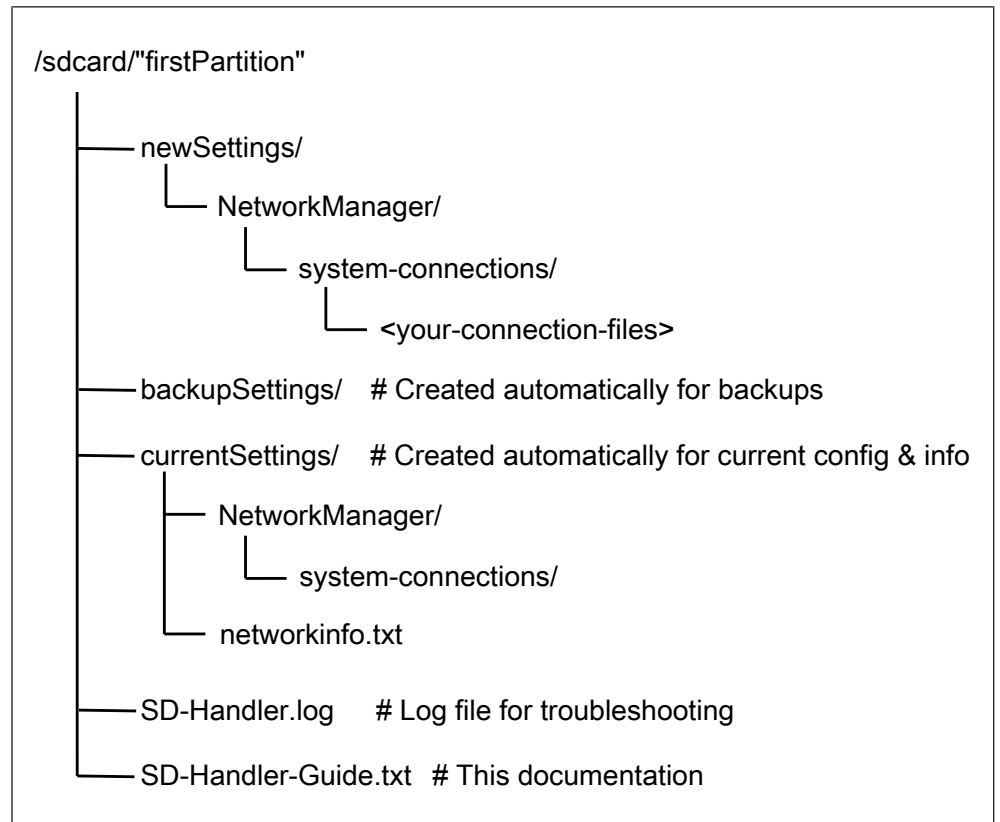

Fig. 42: Folder structure overview

7.7.3 Sample files

1. Static IP configuration (save this as "x2" for the engineering port, for example):

```
[connection]
id=x2
type=ethernet
interface-name=x2
```

```
[ipv4]
method=manual
address1=192.168.0.100/24
gateway=192.168.0.1
dns=8.8.8.8;8.8.4.4;
```

2. DHCP configuration (save this as "x2" for the engineering port, for example):

```
[Connection]
id=x2
type=ethernet
```

```
interface-name=x2
```

```
[ipv4]
```

```
method=auto
```

7.7.4 Step by step

1. Insert the prepared SD card into the device.
2. The system will:
 - Save the current settings to the SD card.
 - Apply new settings from your SD card, if available.
 - Save logs and network information for review.
 - The system LED flashes green/yellow during the process and lights up green when complete or flashes red if an error occurs.
 - The SD LED flashes according to the access to the SD card.
 - After successful application, rename the folder "newSettings" to "newSettings-done".

Notes:

- If a file is invalid, the process is cancelled and the SD card folder is renamed to indicate an error.
- After the process, you can check the logs and current settings on the SD card.
- You can use the files from the folder "currentSettings" as examples for new configurations.
- **NOTICE! x1 is reserved for the fieldbus interface. By default, this interface is not managed. Changes to x1 may affect the behaviour of the fieldbus.**

7.8 Device recovery

Rescue mode

In this mode, the system is loaded from the SD card and executes the corresponding rescue mode.

u-boot

u-boot tries to restore the system environment from the file "rescue.env" to the first (FAT32) volume of the SD card.

Beispiel von "rescue.env":

```
...
```

```
bootpart=1:2
```

```
## KEB Rescue Image
```

```
## In this mode system loads from SD card and runs corresponding rescue mode
```

```
##
```

```
## Available modes: ´reset_network´,´set_network´,´flash_image´
```

```
##
```

```

## Mode 'reset_network' : Removes all changes to network connections.
## Before the reset a backup of the network settings is stored to the sd card.
##
## Mode 'set_network' : Set network connections to given values from `rescue.env`.
##
## Mode 'flash_image' : Initializes eMMC partitions from the
## file `keb-*-image-debian-*-compact-v3*.wic.zst` placed near `rescue.env`.
## Before flashing a backup of the cloud connection configuration and network settings are stored to the sd card.
## ATTENTION: All data on the partitions will be overwritten!
##
## User feedback:
## - All leds will be set to static yellow on beginning of rescue mode
## - All leds will be set to fast blink red_yellow when flashing is active
## - SYS led will be set to blink red on error
## - SYS led will be set to green on success shortly before the device reboots
## - System will disable rescue mode by renaming rescue.env to rescue.env.done after success and reboots automatically from emmc.
## - To enable rescue mode again, rename rescue.env.done to rescue.env
## - Logs are stored to log.txt on the sd-card
##
## Choose exactly one 'rescue_mode=' and comment out others(#):
rescue_mode=reset_network
#rescue_mode=set_network
#rescue_mode=flash_image

# Parameters for mode `set_network`
x2_method=manual # X2 ip4 assignment method: `auto`, `manual`
x2_ip=192.168.0.100/24 # X2 ip4 address with cidr notation (/xx)
x2_gateway=192.168.0.1 # X2 gateway address
x2_dns=8.8.8.8 # X2 dns addresses

...

## Images
The following image file is used for the rescue mode:
- `keb-rescue-image-debian-bookworm-compact-v3.wic.zst` - the image for SD card. It also contains the "rescue.env" file on the first FAT32 volume.
The image can be received from the KEB homepage or via the Support Service.

```

7.9 IIoT Cloud

With NOA Core, the C6 COMPACT 3 has an optional interface to the IIoT cloud NOA Portal from KEB. With NOA Portal, you can enable further use cases for your machines. Possible use cases:

- Condition monitoring and alarming.

- Fleet and asset management.
- Remote maintenance via a VPN connection to the C6 COMPACT 3.

A special feature of NOA Portal is that you can individually configure your IIoT solution and only use the features that you really need for your application.

As an OEM, you have the option of providing your end customers with an instance of NOA Portal and allowing them to benefit from the features of NOA Portal.

Further information on NOA Portal can be found on the KEB website:

(🌐) <https://www.keb-automation.com/products/automation-iiot-plattform>

Contact us if you are interested in NOA Portal and would like access:

(🌐) <https://www.keb-automation.com/forms/contact-form-noa>

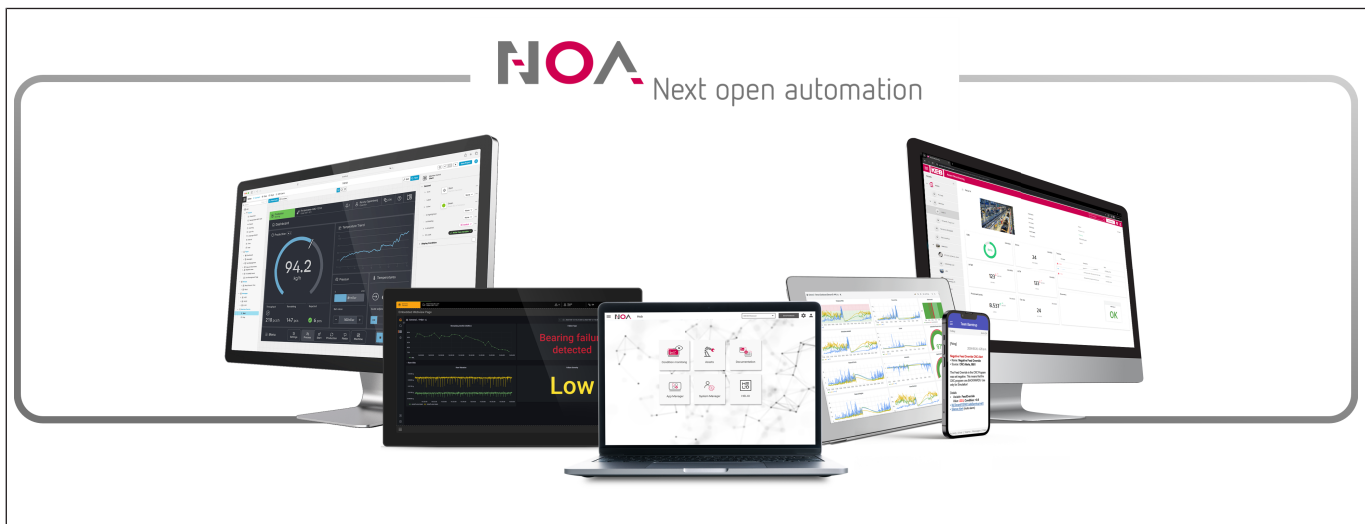

Fig. 43: NOA Portal

7.9.1 Device manager

Click on the **cogwheel** and **devices** to open the device manager.

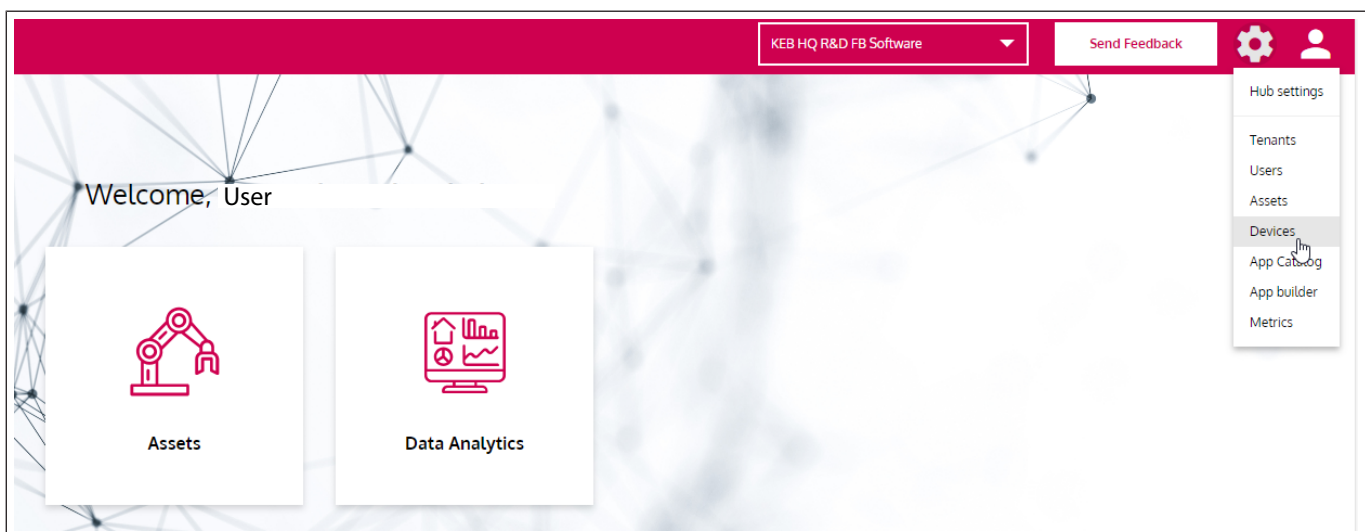

Fig. 44: Open the device list

The device manager lists all installed devices with their name, serial number and location. Clicking on a row allows the corresponding device to be managed.

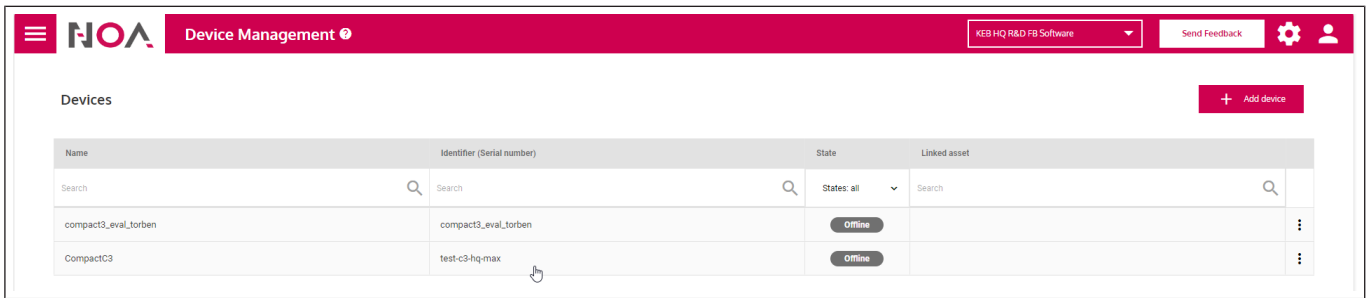

Fig. 45: Device manager with all installed devices

Further options can be selected by clicking on the three dots at the end of the line.

7.9.1.1 General information

General information such as the device name can be changed here. Notes about the device can also be noted.

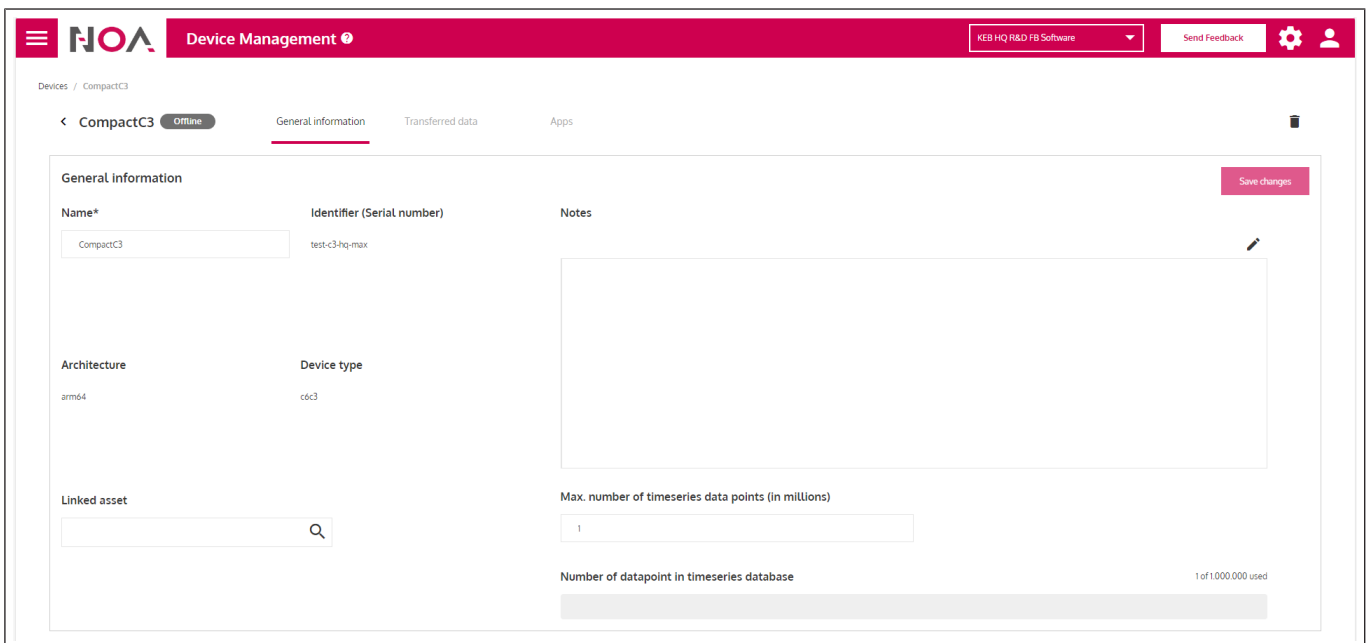

Fig. 46: Editing general information about the device

7.9.1.2 Transferred data

7.9.1.3 Apps

Cloud apps can be installed, removed and updated here. Operation is as in the App Manager.

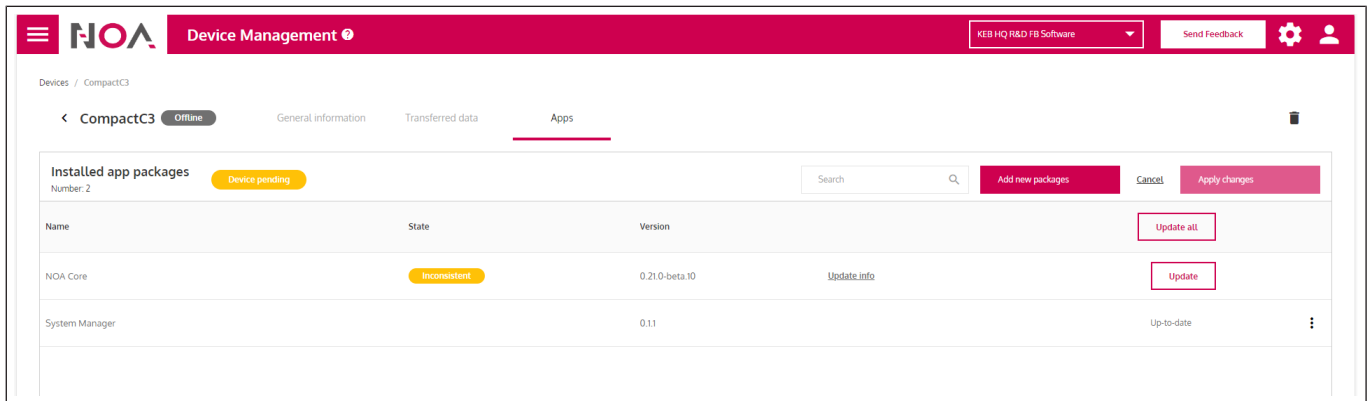

Fig. 47: Install, remove and update apps

8 Maintenance, service and disposal

DANGER



Electrical voltage in the vicinity of the device!

Danger to life due to electric shock !

- ✓ This device is intended for installation in control cabinets or machines that can be operated under dangerous voltages. For any work on the device
 - a) Switch off the supply voltage of the control cabinet or machine.
 - b) Secure it against switching on.
 - c) Wait until all drives has been stopped in order that no regenerative energy can be generated.
 - d) Never bridge upstream protective devices. Also not for test purposes.

8.1 Maintenance

The following maintenance work is to be carried out as required, but at least once a year, by authorised and trained personnel.

- Check unit for loose screws and plugs and tighten if necessary.
- Clean dirt and dust from the devices.
- Checking and cleaning the ventilation inlets and outlets.
- Examine and clean extracted air filter and cooling air filter of the control cabinet.

8.1.1 Cleaning

- Switch off the power before any cleaning operation.
- Clean the front panel of the system with a soft damp cloth.
- Do not use cleaning agents or solvents or other objects that could attack or scratch the surface.

8.1.2 Flash memory

The internal memory of the C6 COMPACT 3 is based on an eMMC.

With frequent write access, you can also use an external memory to extend the lifetime of the read-only memory.

Make regular backups so that you can access your data in the event of an error.

8.2 Service

In case of malfunction, unusual noises or smells inform a person in charge!

DANGER

Unauthorized exchange, repair and modifications

Unpredictable malfunctions

- a) The function of the drive controller is dependent on its parameterisation. Never replace without knowledge of the application.
- b) Modification or repair is permitted only by KEB Automation KG authorized personnel.
- c) Only use original manufacturer parts.
- d) Infringement will annul the liability for resulting consequences.

In case of failure, please contact the machine manufacturer. He can

- supply a corresponding original device.
- supply an authorised replacement part.
- organise the maintenance.

Technical support and repairs

KEB offers wide-ranging, complete after-sales technical support. The staff who deal with this handle questions on the entire range of products skilfully, quickly, and efficiently.

You can phone our staff in the service department, and they will give you complete, prompt advice on how to resolve your problems.

Telephone: +49 (0) 5263 401-0

Fax: +49 (0) 5263 401-116

E-Mail:  service@keb.de

8.3 Disposal

Electronic devices of KEB Automation KG are intended for professional, commercial processing (so-called B2B devices).

Manufacturers of B2B devices are obliged to take back and recycle devices manufactured after 14.08.2018. In principle, these devices may not be left at public or communal recycling or collection points.



Unless otherwise agreed between the customer and KEB or unless there is a deviating mandatory legal regulation, KEB products labelled in this way can be returned. Company and keyword for the return point can be found in the list below.

Shipping costs are at the expense of the customer. The devices are then professionally recycled and disposed of.

The entry numbers are listed country-specifically in the following table. KEB addresses can be found on our website.

Withdrawal by	WEEE registration no.	Keyword
Germany		
KEB Automation KG	EAR: DE12653519	Keyword: "Withdrawal WEEE"
France		
RÉCYLUM – Recycle point	ADEME: FR021806	Mots clés "KEB DEEE"
Italy		
COBAT	AEE: (IT) 19030000011216	Parola chiave "Ritiro RAEE"
Austria		
KEB Automation GmbH	ERA: 51976	Keyword: "Withdrawal WEEE"
Spain		
KEB Automation KG	RII-AEE: 7427	Palabra clave "Retirada RAEE"
Czech republic		
KEB Automation KG	RETELA: 09281/20-ECZ	Klíčové slovo "Zpětný odběr OEEZ"
Slovakia		
KEB Automation KG	ASEKOL: RV22EEZ0000421	Kľúčové slovo: "Spätný odber OEEZ"

The packaging must be sent for paper and cardboard recycling.

9 Certification

Current certificates, declarations and revision lists for your product can be viewed or downloaded from our website at the following link:

( keb-automation.com/search)

By entering the article number, you will receive a list of the corresponding documents in the "Certificates" drop-down menu.

If you need help or further documentation, please contact our customer service.

9.1 CE marking

Conformity with the EU directives and guidelines applicable on the production date is confirmed by the CE mark on the nameplate.

The current EU Declaration of Conformity for this product is available via the link above.

9.2 UL certification

UL (Underwriters Laboratories) approval ensures that a product fulfils the safety-related requirements for the North American market. UL is an independent organisation that tests and certifies products, components and systems for safety, quality and conformity with applicable standards.

Products that have received UL approval are marked with the UL logo on the nameplate. This symbol indicates that the product has been successfully tested in accordance with UL specifications and is approved for use in the USA or Canada. Depending on the type of approval, the logo with the UL file can also be marked with additional information (e.g. "cULus" for Canada and the USA).

The approval is linked to certain requirements. These are marked accordingly in this and/or further instructions. Only the assemblies/components described in the approval may be used.

A deviation from the tested specifications or the use of non-certified parts can lead to the loss of UL approval and thus jeopardise the operating permit in the target market.

9.3 Further markings

Other markings and approvals not listed here are identified by a corresponding logo on the rating plate or device, if applicable. The corresponding certificates are available on our website.

10 Revision History

Edition	Ver.	Note	FS
-	00	Prototype	N
2025-01	01	Pre-series version	N
2025-02	02	Terminal strip X5 renamed to X6. Series version created.	N
2025-04	03	Assignment of terminal strip X6 changed.	N
2025-05	04	Login name for NOA changed.	N
2025-07	05	Product information changed; light pattern removed in CAN mode; status display changes; added examples for calling the NOA UI Hub; description Network extended; App Manager revised. Chapter OS and bootloader update and device recovery added. Certification section revised. Technical data protection changed. Type plate changed. Chapter on SD card handling added. Editorial changes.	N
2025-12	06	Bootloader update revised.	N

FS: (J) Version contains safety-related changes; (N) Version contains changes for product improvement or troubleshooting.

List of figures

Fig. 1	Nameplate.....	14
Fig. 2	C6 COMPACT 3 front view of models 1 and 3.....	16
Fig. 3	C6 COMPACT 3 front view model 2.....	16
Fig. 4	C6 COMPACT 3 front view model 4.....	17
Fig. 5	C6 COMPACT 3 top Model 1 and 2.....	17
Fig. 6	C6 COMPACT 3 top Model 3.....	18
Fig. 7	C6 COMPACT 3 top Model 4.....	18
Fig. 8	C6 COMPACT 3 bottom Model 1, 2 and 3.....	19
Fig. 9	C6 COMPACT 3 bottom Model 4.....	19
Fig. 10	C6 COMPACT 3 rear view.....	20
Fig. 11	Dimensions COMPACT 3.....	23
Fig. 12	Installation distances.....	24
Fig. 13	Mounting on a mounting rail.....	25
Fig. 14	Disassembly of the mounting rail.....	25
Fig. 15	RJ45 socket front view.....	29
Fig. 16	RJ45 socket front view.....	30
Fig. 17	RJ45 socket front view.....	30
Fig. 18	Connection CAN bus.....	32
Fig. 19	X10 INTERBUS input.....	34
Fig. 20	X11 INTERBUS output.....	34
Fig. 21	INTERBUS remote bus cable assignment.....	35
Fig. 22	Software structure INTERBUS extension.....	35
Fig. 23	find IP address.....	41
Fig. 24	Peer-to-peer connection.....	42
Fig. 25	Starting the NOA UI Hub.....	43
Fig. 26	Select the app and start.....	44
Fig. 27	Login NOA Edge.....	45
Fig. 28	Automatic logout.....	46
Fig. 29	System Manager overview.....	47
Fig. 30	System Manager - Network.....	48
Fig. 31	System Manager date and time.....	48
Fig. 32	System Manager - Partitions.....	49
Fig. 33	System Manager - Log-files.....	49
Fig. 34	System Manager - Device LEDs.....	50
Fig. 35	Licence Manager - My licences.....	50
Fig. 36	App Manager - Installed apps.....	51
Fig. 37	Open the app catalog.....	51
Fig. 38	Start installation of new apps.....	52
Fig. 39	Mark the app to be deleted.....	53
Fig. 40	Delete apps.....	53
Fig. 41	OS Image Update.....	54

Fig. 42	Folder structure overview	55
Fig. 43	NOA Portal	58
Fig. 44	Open the device list.....	58
Fig. 45	Device manager with all installed devices.....	59
Fig. 46	Editing general information about the device	59
Fig. 47	Install, remove and update apps	60

List of tables

Tab. 1	Release notes	15
Tab. 2	Wire end ferrules and stripping length	26
Tab. 3	Assignment of terminal block X6	27
Tab. 4	PIN assignment RJ45 EtherCAT	29
Tab. 5	Function of the LEDs.....	29
Tab. 6	PIN assignment RJ45 Ethernet.....	29
Tab. 7	Function of the LEDs.....	30
Tab. 8	PIN assignment RJ45 Ethernet.....	30
Tab. 9	Function of the LEDs.....	30
Tab. 10	Assignment of terminal block X6.....	31
Tab. 11	Assignment of terminal block X6.....	33
Tab. 12	Assignment of terminal block X6.....	34
Tab. 13	DIP switch 4-fold	35
Tab. 14	Specification INTERBUS remote bus cable.....	35
Tab. 15	Software components of the INTERBUS extension.....	36
Tab. 16	SYS LED flashing pattern during boot process.....	39
Tab. 17	Flashing pattern SYS LED in operation	39
Tab. 18	Flashing pattern PLC LED	40
Tab. 19	Flashing pattern APP LED	40
Tab. 20	Flashing pattern SD LED	40
Tab. 21	Flashing pattern LD5 LED (USER mode)	40
Tab. 22	Flashing pattern BUS LED	40
Tab. 23	Browser depending on the device.....	41

Glossary

2W

2-Wire; is used in the field of network technology for serial full duplex operation.

A/B Update

An A/B update uses two partitions (one active and one inactive partition). During the update, the system will be installed on the inactive partition. If an error occurs during the update, you can switch back to the old working partition.

Application

The application is the intended use of the KEB product.

Autonegotiation

Procedure for determining the max. transmission speed.

CAN®

Serial bus system running protocols such as CANopen, Devicenet or J1939. CAN is a registered trademark of the CAN in AUTOMATION - International Users and Manufactures Group e.V.

COMBIVERT

Proper name for a KEB Drive Controller.

Customer

The customer has purchased a product from KEB and integrates the KEB product into his product (customer product) or resells the KEB product (reseller).

eFuse

Very fast electronically programmable fuse.

eMMC

Embedded Multi Media Card consisting of flash memory and memory controller.

EN 60529

Degrees of protection provided by enclosures (IP-Code).

EN 61131-2

Programmable controllers - Part 2: Equipment requirements and tests. German version VDE 0411-500.

EN IEC 61010-2-201

Safety requirements for electrical equipment for measurement, control, and laboratory use - Part 2: Particular requirements for control equipment. German version VDE 0411-2-201.

EN 60715

Dimensions of low-voltage switchgear and controlgear -Standardized mounting on rails for mechanical support of electrical devices in switchgear and controlgear installations. German version VDE 0660-520.

EtherCAT®



EtherCAT®

EtherCAT is a real-time Ethernet bus system. EtherCAT is a registered trademark and patented technology, licensed by Beckhoff Automation GmbH, Germany.

Ethernet

Real-time bus system - defines protocols, plugs, types of cables

HD 60364-4-41

Electrical installations of buildings Part 4-41 Protection for safety; Protection against electric shock. German version VDE 0100-410.

HD 60364-5-54

Low-voltage electrical installations - Part 5-54: Selection and erection of electrical equipment - Earthing arrangements, protective conductors and protective bonding conductors. German version VDE 0100-540.

HMI

Human-Machine-Interface describes a visual user interface (touchscreen).

IDE

Integrated Development Environment

IEC 61131-3

Programmable controllers - Part 3: Programming languages (German version DIN EN 61131-3)

NHN

Standard altitude zero; related to the established height definition in Germany (DHHN2016). The international data usually deviate from this by only a few cm to dm, so that the value is given can be taken from the regionally applicable definition.

PELV

Safe protective extra-low voltage (earthed).

RS485

RS-485 is an industry standard according to EIA-485 for a physical interface for asynchronous, serial data transmission.

RTC

Real Time Clock

SELV

Safe extra-low voltage (unearthed).

UPS

Uninterruptible power supply for bridging power failures or to bring the device into a defined state.

Index

M

Maintenance work	61
------------------	----

P

Packaging	62
-----------	----

R

Return point	62
--------------	----



MORE KEB PARTNERS WORLDWIDE:
www.keb-automation.com/contact





Automation with Drive

www.keb-automation.com

KEB Automation KG • Suedstraße 38 • D-32683 Barntrup • Tel: +49 5263 401-0 • E-Mail: info@keb.de