

USING THE QUICK GUIDE

- Serves for safe handling with the KEB drive controller.
- Provides information on handling, assembly and installation.
- Remains for later use at the drive controller.
- Does **not** replace the electronically provided instructions for use.

This manual is intended exclusively for persons who are familiar with the logistics and installation. The person must have the following qualifications:

- Knowledge and understanding of the safety instructions.
- Skills for installation and assembly.
- Understanding of the function in the used machine.
- Detection of hazards and risks of the electrical drive technology.
- Knowledge of IEC 60364-5-54.
- Knowledge of national safety regulations (e.g. DGUV Regulation 3).

SAFETY INSTRUCTIONS

⚠ DANGER Interventions by unauthorised personnel!



Danger to life by electric shock and malfunction!

- Modification or repair is only permitted by KEB authorised personnel.

NOTICE



Getting more documentation

Hazards and risks through ignorance.

- Open the KEB homepage at www.keb-automation.com.
- By entering the material number in the search field, you will get the corresponding parts of the instructions for use.
- Read the instructions for use carefully!
- Observe the safety and warning instructions!
- If you have any questions, please contact service@keb.de!

TRANSPORT

The transport must be carried out by instructed persons, observing the following instructions.

⚠ CAUTION



Maximum design edges and high weight!

Contusions and bruises!

- Never stand under suspended loads.
- Wear safety shoes.
- Secure drive controller accordingly when using lifting gear.

NOTICE



Behaviour in case of transport damage

- When receiving goods, check the device for transport damage such as deformations or loose parts.
- In case of damage, contact the carrier immediately.
- Do not operate the device in case of transport damage!

STORAGE

Do not store drive controllers

- in the environment of aggressive and/or conductive liquids or gases.
- in locations exposed to direct sunlight.
- outside the specified environmental conditions.

UNPACKING AND CHECKING

- Make sure that no components are bent and/or isolation distances are changed.
- The device must not be put into operation in case of mechanical defects. There is no compliance with applicable safety standards any more.



The electrolytic capacitors of the DC link must be reformed if the drive controller was stored or out of operation for more than one year. See www.keb.de/nc/search with search term "electrolytic capacitors".

INSTALLATION



Drive controllers contain electrostatic sensitive components.

- Avoid contact.
- Wear ESD-protective clothing.

- Do not allow moisture or mist to penetrate the device. Mount the drive controller according to the required degree of protection.

- Make sure that no small parts fall into the device during assembly and wiring (drilling chips, screws etc.). This also applies to mechanical components, which can lose small parts during operation.

- The device is intended for the use in a pollution degree 2 environment.
- Maximum ambient temperature 45°C
- UL/CSA: For push-through models only: For the heat sink extending the ultimate enclosure - "NEMA Type 1".
- UL/CSA: Use only 75°C copper cables for UL-compliant connections for all power connections!
- CSA: For installations according to the Canadian National Standard C22.2 No. 274-13 overvoltage category III.

START-UP AND OPERATION

⚠ WARNING

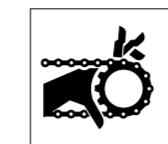

Function of the drive controller determines the machine manufacturer!

Hazards caused by unintentional behavior of the drive!

- The documentation of the machine manufacturer is required for the start-up and operation of the product.
- Check especially during initial start-up or replacement of the drive controller if parameterisation is compatible to application.
- The drive controller must not be started until it is determined that the installation complies with the machine directive; EN 60204-1 must be observed.

⚠ WARNING



Triggering of overcurrent protection devices

Risk of fire or electric shock!

- Triggering of an overcurrent protection device will be a hint for an overload or short circuit. Triggering a RCD may be caused by a leakage current.
- In order to reduce the risk of fire or electric shock, live parts and other components of the controller should be checked and replaced in case of damage.
- If the contacts of an overload relay are burned, the complete relay must be replaced.

⚠ CAUTION



High sound pressure level during operation!

Hearing damage possible!

- Wear hearing protection!

MAINTENANCE

⚠ DANGER



Unauthorised exchange, repair and modifications!

Unpredictable malfunctions!

- The function of the drive controller is dependent on its parameterisation. Never replace without knowledge of the application.
- Modification or repair is permitted only by KEB Automation KG authorised personnel.
- Only use original manufacturer parts.

The following maintenance work has to be carried out when required, but at least once a year by authorised and trained personnel.

- Clean the drive controller from dirt and dust deposits. Pay attention especially to cooling fins and protective grid of the fans.
- Check the function of the fans of the drive controller. The fans must be replaced in case of audible vibrations or squeak.
- Make a visual test of the cooling circuit for leaks and corrosion at liquid-cooled drive controllers.
- In case of malfunction, unusual noises or smells inform a person in charge!
- In case of failure, please contact the machine manufacturer. Only the machine manufacturer knows the parameterisation of the used drive controller and can provide an appropriate replacement or induce the maintenance.

INSTALLATION / ELECTRICAL CONNECTION

⚠ DANGER



Voltage at the terminals and in the device!

Danger to life by electric shock!

- Never work under voltage on the open device or touch exposed parts.
- For any work on the unit switch off the supply voltage and secure it against switching on.
- Wait until the mechanical drive system has stopped in order that no regenerative energy can be generated.
- Wait until the DC link capacitors are discharged (5 minutes). Verify by measuring the DC voltage at the terminals.
- If personal protection is required, install suitable protective devices for drive controllers.
- Never bridge upstream protective devices (also not for test purposes).
- Connect the protective earth conductor properly to drive controller and motor.
- Leakage current higher than 3.5 mA: The minimum cross section of the protective earth conductor must comply with local safety regulations for protective earth conductors for equipment with high leakage current.
- Install all required covers and protective devices for operation.
- Residual current: This product can cause a DC current in the protective earth conductor. When a residual current device (RCD) or a residual current monitor (RCM) is used for the protection of direct or indirect contact, only a RCD or RCM of Type B is permitted for this product on the power supply side.

For a trouble-free and safe operation, please pay attention to the following instructions:

- Check for reliable fit of the device connections in order to minimise contact resistance and avoid sparking.
- Connection of the drive controller is only permissible on symmetrical networks with a maximum line voltage (L1, L2, L3) with respect to earth (N/PE) of maximum 300V. USA UL: 480/277V. An isolating transformer must be used for supply networks which exceed this value. In case of non-compliance the control circuits are no longer considered as "safe separate circuit".
- Within systems or machines the person installing electrical wiring must ensure that an existing or new wired safe ELV circuits the EN requirement for safe installation is still met!
- For drive controllers that are not isolated from the supply circuit (in accordance with EN 61800-5-1) all control lines must include other protective measures (e.g. double insulation or shielded, earthed and insulated).

MOUNTING DISTANCES

Mounting orientation	Mounting distances	Dimension	Distance in mm / inch
		A	150 / 6
		B	100 / 4
		C	30 / 1,2
		D	0
		E	0
		F 1)	50 / 2

1) Distance between front of drive unit and control cabinet door.

PROTECTION

Information on the permissible fuses for the devices can be found in the instructions for use for the corresponding housings and on a sticker included in the delivery.



For a complete overview, see "Fuse protection" technical information.
www.keb-automation.com/0001



BRAKING RESISTORS

F6 Housing	DC voltage in V	Cycle time in s	Max. cyclic duration factor			
			Side-mounted s	Side-mounted %	Sub-mounted s	Sub-mounted %
4	780	120	60	50	0,95	0,79
6					0,9	0,75
7					0,9	0,75
8					0,62	0,52
9					0,6	0,5
9					30	25

1) Integrated sub-mount filters.

BRAKING TRANSISTOR

F6 Housing	Cycle time in s	Max. cyclic duration factor in %
2, 3, 4, 6, 7, 8	120	50
9	120	25

1) The cyclic duration factor is additionally limited by the used braking resistor.

WIRING

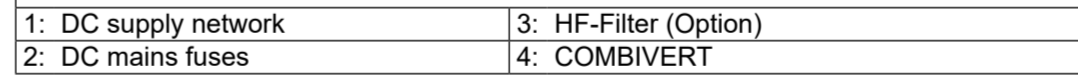
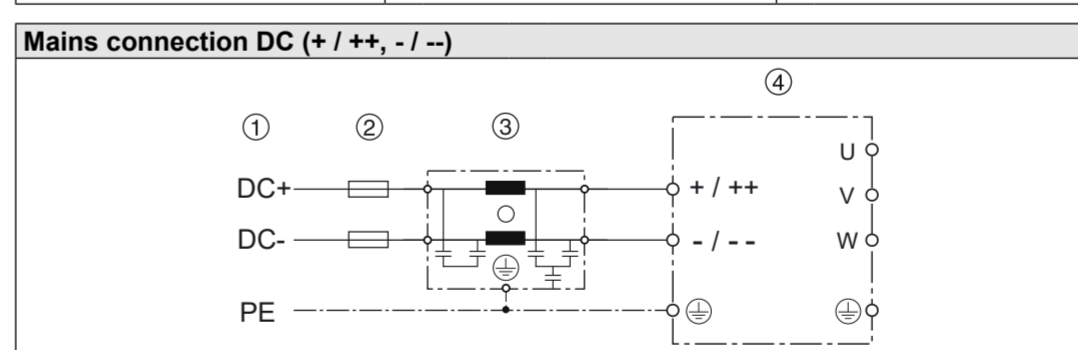
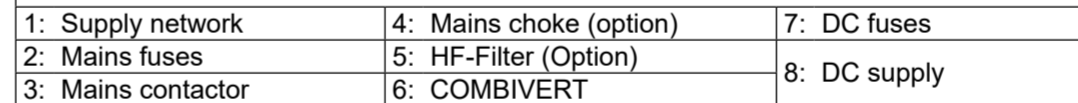
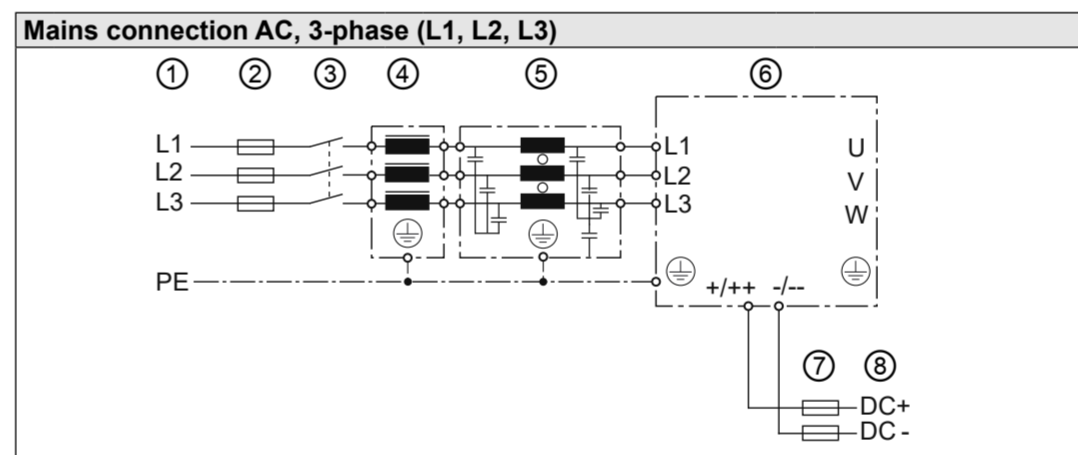

NOTICE

Destruction of the drive controller!

- When supplied via the DC terminals, please also note the following:
- F6 housing 3...9 require external precharging.
 - Never swap "+ / ++" and "- / --".

Connection braking resistor

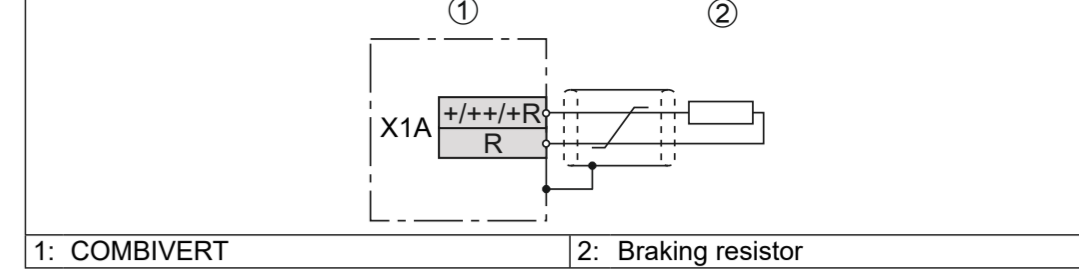

24V supply control unit

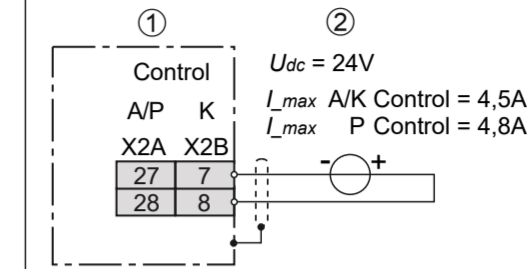

Connection of control unit

The connection of the control depends on the programming of the machine manufacturer. See the documentation for the machine. Overcurrent protection required! Control board rating of relays is DC 30V / 1A.

Housing	No. from Table 2 Terminal block(s)						
	L1, L2 (N), L3	U, V, W	+, -, ++, --, R, +R	X1C	X2A-D FAN PE		
F6 2	2	2	2	1	1		
F6 3	4	4	3 ¹⁾ /4				
F6 4	5	5	5				
F6 6	9	9	9				
F6 7	10	10	10				
F6 8	11	11	11				
F6 9	12	12	12				
						13	

Table 1: Assignment of terminals to terminal numbers

1) The specification applies only to terminals R and +R.

No. from Table 1	Mounting type	Permissible cross section		Tightening torque	
		mm ² with wire end ferrule	AWG without wire end ferrule	Nm	lb inch
1	Push-In terminal	0,14...1,5 ¹⁾	—	—	—
2	Screw terminal	2,5...10	26...6	1,5	13
3	Screw terminal	0,5...16	20...6	1,2...1,5	11...13
4	Screw terminal	0,5...35	20...2	2,5...4,5	23...40
5	Screw terminal	1,5...35	16...1	3,2...3,7	28...32
6	M4 screw ²⁾	—	—	1,3	11
7	M5 bolt ²⁾	—	—	6...8	53...70
8	M6 bolt ²⁾	—	—	6,1...12	54...106
9	M8 bolt ²⁾	—	—	10...15	88...132
10	M10 bolt ²⁾	—	—	25	220
11	M12 bolt ²⁾	—	—	35	310
12	M16 bolt ²⁾	—	—	35	310
13	Screw terminal	0,2...4 1,5 max. with 2 conductors	24...10 14 max. with 2 conductors	0,5...0,6	4,5...5,3

Table 2: Assignment of terminal number to cross section and tightening torque

1) Malfunctions caused by loose cable connections and too short wire end ferrules!

- Use wire end ferrules according to table 3 Wire end ferrules and stripping length.
- Strip cable according to table 3 Wire end ferrules and stripping length.

2) For crimp connectors.

- Cable cross-sections and fuses must be dimensioned according to the design of the machine manufacturer. Specified minimum / maximum values may not be fallen below / exceeded.

Cross section	Wire end ferrule	Metal sleeve length	Stripping length
0.50 mm ²	with plastic collars (DIN 46228-4)	10 mm	12 mm
0.75 mm ²		12 mm	14 mm
1.00 mm ²		12 mm	15 mm
1.50 mm ²	without plastic collars (DIN 46228-1)	10 mm	10 mm
0.14...1.5 mm ² single or finewire	without wire end ferrule	—	10...15 mm

Table 3: Wire end ferrules and stripping length

FLUID COOLER

F6 Housing	Volume flow / l/min			Connection Ø		
	Water	Oil	Water (High-Performance)	Water	Oil	Water (High-Performance)
3	3...15	—	—	10 mm	—	—
4	5...15	15...25	—	10 mm	G 1/2"	—
6	5...15	15...25	15...25	10 mm	G 1/2"	—
7	6...20	—	20...30 (Gr. 26) 25...30 (Gr. 28)	12 mm	—	18 mm
8	10...33	—	15...30	15 mm	—	18 mm
9	10...33	—	25...35 (Gr. 30) 25...40 (Gr. 31) 30...40 (Gr. 32) 35...40 (Gr. 33)	15 mm	—	18 mm

- Maximum pressure for liquid-cooled drive controllers 10 bar (145 psi).
- Temperature range fluid cooler, water: 5...40°C, water H.-P.: 5...55°C, oil: 40...55°C.
- Coolant: Water or water-glycol mixture with a maximum volume fraction of 52%.



- The volume flow depends on the power dissipation.
- Temperature range of high-performance fluid coolers may vary.
- Observe information on fluid coolers.
- See instructions for use.

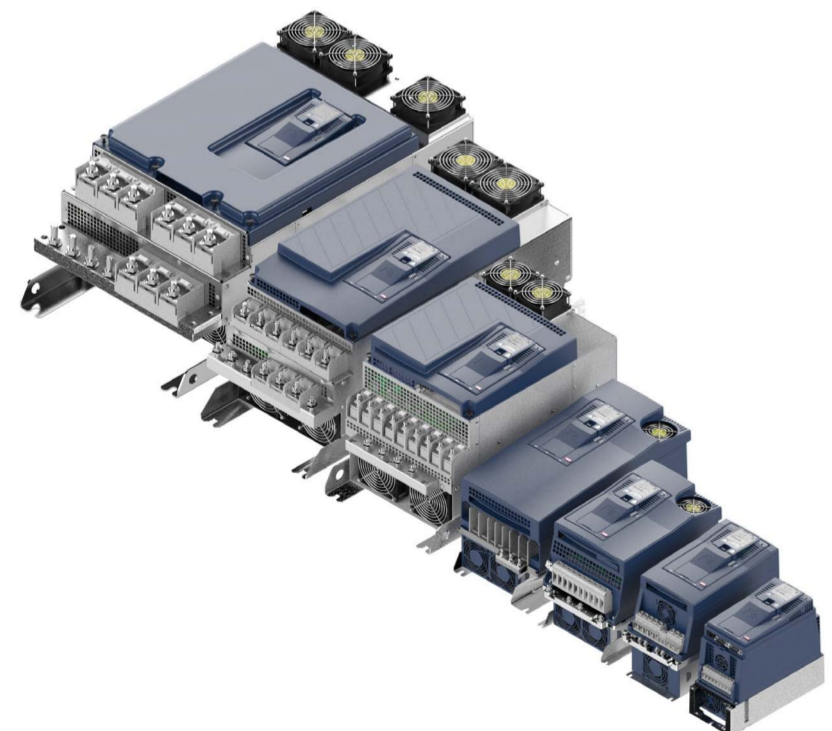

COMBIVERT F6

QUICK START GUIDE

Translation of the original manual
F6 Series Housing 2, 3, 4, 6, 7, 8, 9
Document 20162225 EN 13

Mat.No. 00F6N1M-0005

HOUSING DIMENSIONS

HOUSING 2 BUILT-IN VERSION

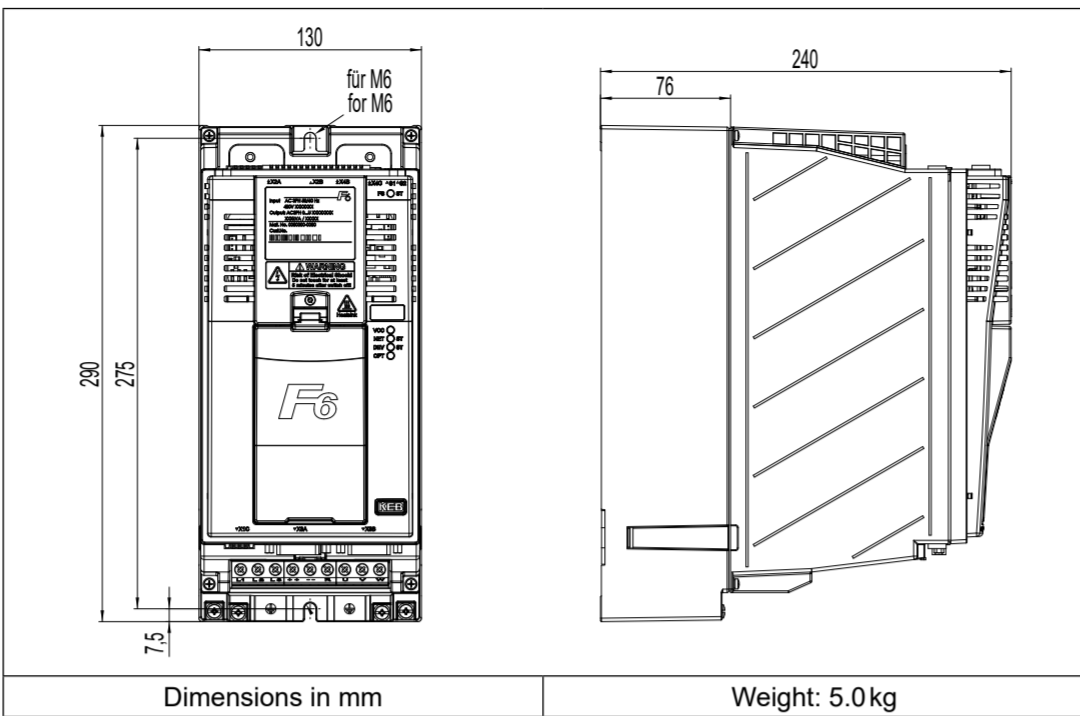

Dimensions in mm Weight: 5.0 kg

HOUSING 3 BUILT-IN VERSION

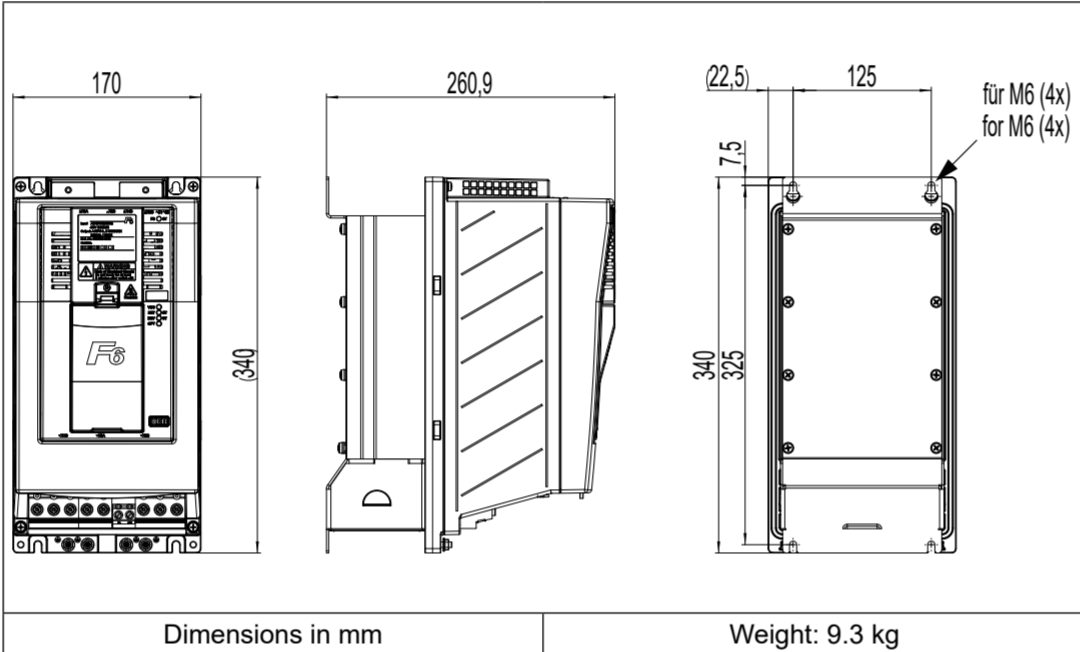

Dimensions in mm Weight: 9.3 kg

HOUSING 4 BUILT-IN VERSION

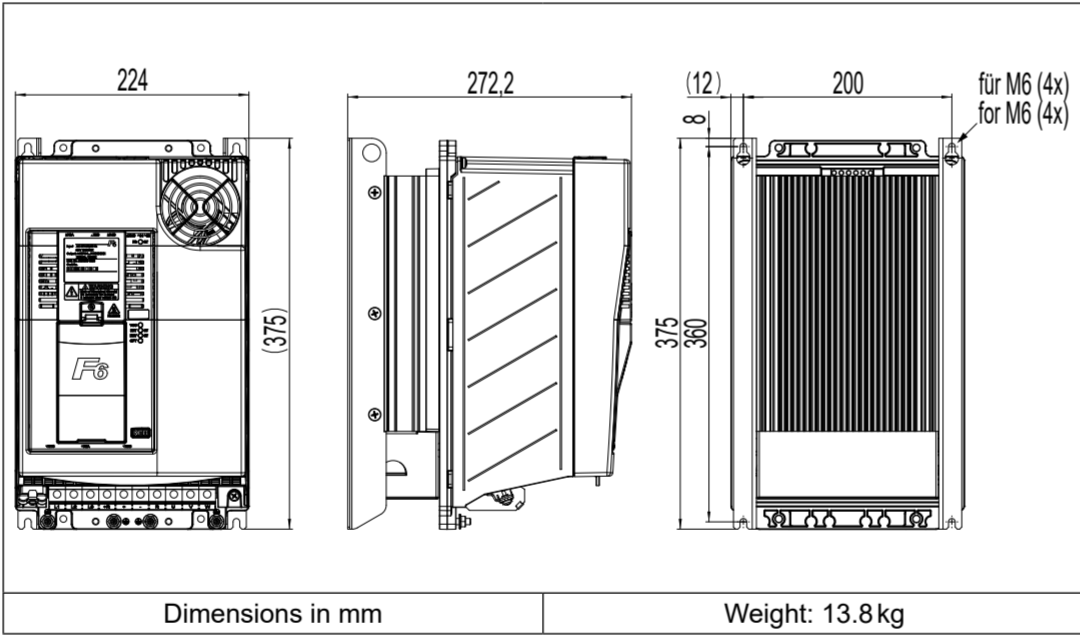

Dimensions in mm Weight: 13.8 kg

HOUSING 6 BUILT-IN VERSION

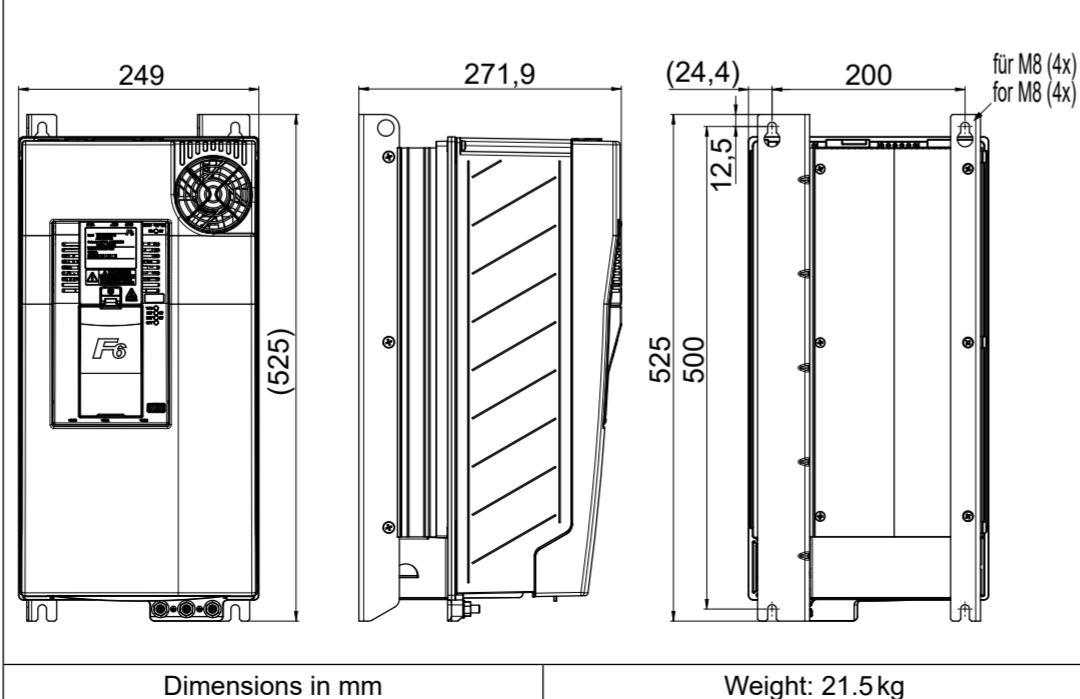

Dimensions in mm Weight: 21.5 kg

HOUSING 7 BUILT-IN VERSION

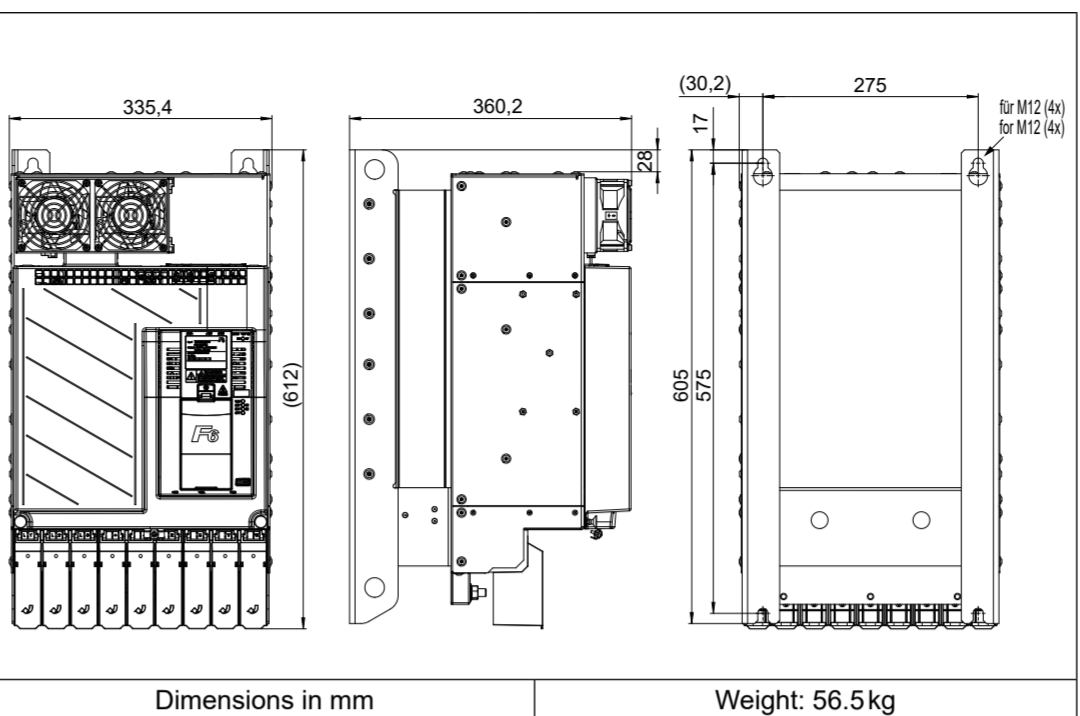

Dimensions in mm Weight: 56.5 kg

HOUSING 8 BUILT-IN VERSION

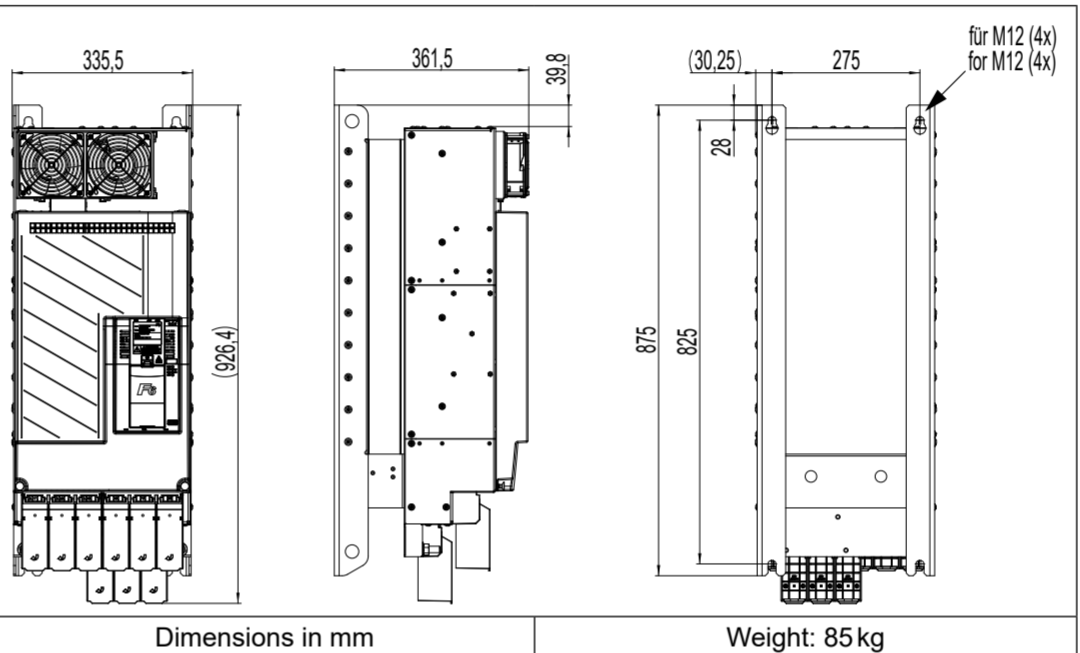

Dimensions in mm Weight: 85 kg

HOUSING 9 BUILT-IN VERSION

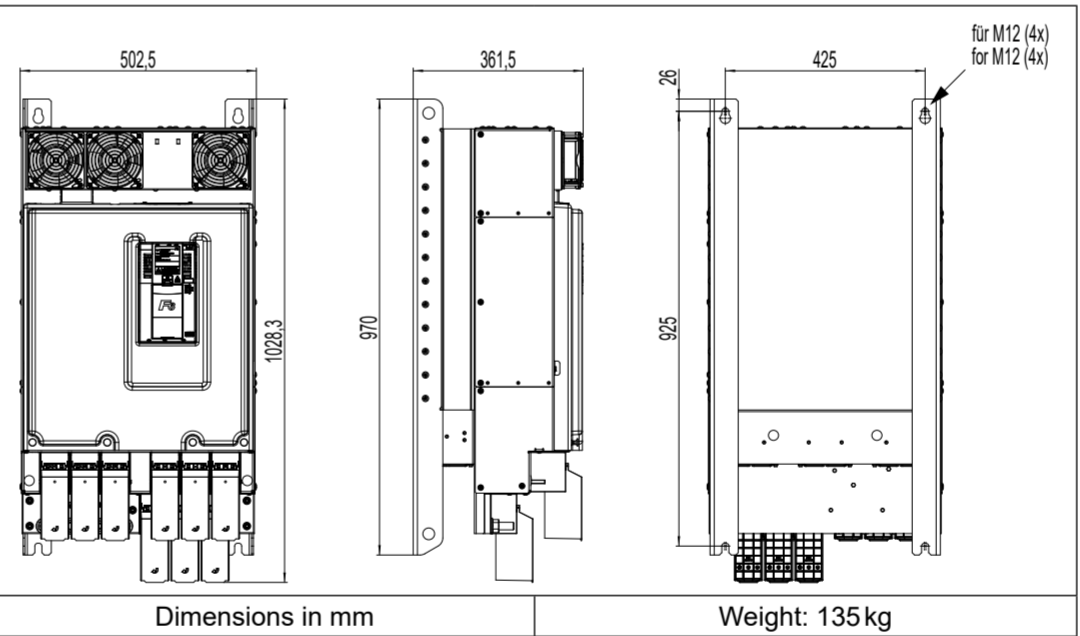

Dimensions in mm Weight: 135 kg

i The housing dimensions of other model variants can be found in the instructions for use of the corresponding housings.

CERTIFICATION

CE certification

CE KEB products meet the requirements of the valid European and national directives. The conformity has been proven. The corresponding declarations can be downloaded from our website by entering the material number in the search field.

FS certification

FS For devices with FS logo on the nameplate, the corresponding KEB safety manual must be observed!

During the UL evaluation, only electrical safety and risk of fire aspects were investigated. Functional safety aspects were not evaluated. Devices with safety function are limited to a service life of 20 years. Then the devices must be replaced.



See www.keb.de/hc/search with search term "safety manual".

UL certification

NOTICE UL certification

Only devices with UL logo on the name plate are certified.

i For compliance with UL for use in the North American and Canadian Market, the following additional information must be observed (English original text):

BRANCH CIRCUIT PROTECTION

- ▶ Integral solid state short circuit protection does not provide branch circuit protection.
- ▶ Branch circuit protection must be provided in accordance with the Manufacturer Instructions, National Electrical Code and any additional local codes".
- ▶ CSA: For Canada: Branch circuit protection must be provided in accordance with the Canadian Electrical Code, Part I.

WARNING

▶ THE OPENING OF THE BRANCH-CIRCUIT PROTECTIVE DEVICE MAY BE AN INDICATION THAT A FAULT HAS BEEN INTERRUPTED. TO REDUCE THE RISK OF FIRE OR ELECTRIC SHOCK, CURRENT-CARRYING PARTS AND OTHER COMPONENTS OF THE CONTROLLER SHOULD BE EXAMINED AND REPLACED IF DAMAGED. IF BURNOUT OF THE CURRENT ELEMENT OF AN OVERLOAD RELAY OCCURS, THE COMPLETE OVERLOAD RELAY MUST BE REPLACED.

AVERTISSEMENT

▶ LE DÉCLENCHEMENT DU DISPOSITIF DE PROTECTION DU CIRCUIT DE DÉRIVATION PEUT ÊTRE DÙ À UNE COUPURE QUI RÉSULTE D'UN COURANT DE DÉFAUT. POUR LIMITER LE RISQUE D'INCENDIE OU DE CHOC ÉLECTRIQUE, EXAMINER LES PIÈCES PORTEUSES DE COURANT ET LES AUTRES ÉLÉMENTS DU CONTRÔLEUR ET LES REMPLACER S'ILS SONT ENDOMMAGÉS. EN CAS DE GRILLAGE DE L'ÉLÉMENT TRAVERSÉ PAR LE COURANT DANS UN RELAIS DE SURCHARGE, LE RELAIS TOUT ENTIER DOIT ÊTRE REMPLACÉ.

GROUNDING SYSTEM

- ▶ All 480Vac / 3-ph Models:
„Only for use in non-corner grounded type WYE source not exceeding 277 V phase to ground“ (or equivalent).
- ▶ All 200-240Vac / 3-ph Models:
“Only for use in non-corner grounded type WYE source not exceeding 139 V phase to ground“ (or equivalent).

UK Conformity Assessed

UK Conformity Assessed

KEB products with the listed logo meet the requirements and guidelines of Great Britain. The corresponding information can be obtained on our website by entering the material number in the search field or from our authorised contact person below:

KEB(UK) Ltd.
5 Morris Ct, Park Farm Industrial Estate,
Wellingborough NN8 6XF, UK

DISPOSAL

- ▶ For professional disposal, follow the instructions in the instructions for use

INSTRUCTIONS FOR USE

- ▶ Open the KEB homepage at www.keb-automation.com.
- ▶ By entering the material number in the search field, you will get the corresponding parts of the instructions for use.
- ▶ Read the instructions for use carefully!

KEB Online	www.keb-automation.com	KR	다른 언어도 사용할 수 있습니다.
BG	Други налични езици.	HR	Ostali dostupni jezici.
CN	其他语言可用。	HU	Más elérhető nyelvek.
CZ	Jiné jazyky k dispozici.	LV	Citas pieejamās valodas.
DK	Andre sprog til rådighed.	LT	Kitos kalbos.
DE	Weiteren Sprachen verfügbar.	MT	Lingwi oħra disponibbli.
EN	Other languages available.	NL	Andere talen beschikbaar.
EE	Muud keeled on saadaval.	PL	Inne dostępne języki.
ES	Otros idiomas disponibles.	PT	Outros idiomas disponíveis.
FI	Muut kielet saatavilla.	RO	Alte limbi disponibile.
FR	Autres langues disponibles.	RU	Доступны другие языки.
GR	Άλλες διαθέσιμες γλώσσες.	SE	Andra språk finns tillgängliga.
IE	Teangacha eile ar fáil.	SK	Iné jazyky sú k dispozícii.
IT	Altre lingue disponibili.	SI	Drugi jeziki so na voljo.
JP	他の言語も利用できます。	TR	Mevcut diğer diller.