



# COMBIVERT F6

INSTRUCTIONS FOR USE | INSTALLATION F6 HOUSING 3

Translation of the original manual  
Document 20128423 EN 08



# Preface

The hardware and software described in this document are products of KEB. The information contained in this document is valid at the time of publishing. KEB reserves the right to update this document in response to misprints, mistakes or technical changes.

## Signal words and symbols

Certain procedures within this document can cause safety hazards during the installation or operation of the device. Refer to the safety warnings in this document when performing these procedures. Safety signs are also located on the device where applicable. A safety warning is marked by one of the following warning signs:

<b>DANGER</b>	Dangerous situation, which will cause death or serious injury if this safety warning is ignored.
<b>WARNING</b>	Dangerous situation, which may cause death or serious injury if this safety warning is ignored.
<b>CAUTION</b>	Dangerous situation, which may cause minor injury if this safety warning is ignored.
<b>NOTICE</b>	Situation, which can cause damage to property if this safety warning is ignored.

### RESTRICTION

Used when the following statements depend on certain conditions or are only valid for certain ranges of values.



Used for informational messages or recommended procedures.

## More symbols

- ▶ This arrow starts an action step.
- / - Enumerations are marked with dots or indents.
- => Cross reference to another chapter or another page.



Note to further documentation.  
<https://www.keb-automation.com/search>



## Laws and guidelines

KEB Automation KG confirms with the EC declaration of conformity and the CE mark on the device nameplate that it complies with the essential safety requirements.

The EC declaration of conformity can be downloaded on demand via our website.

## Warranty and liability

The warranty and liability on design, material or workmanship for the acquired device is given in the general sales conditions.



Here you will find our general sales conditions.

<https://www.keb-automation.com/terms-conditions>



Further agreements or specifications require a written confirmation.

## Support

Although multiple applications are referenced, not every case has been taking into account. If you require further information or if problems occur which are not referenced in the documentation, you can request the necessary information via the local KEB agency.

**The use of our units in the target products is outside of our control and therefore lies exclusively in the area of responsibility of the customer.**

The information contained in the technical documentation, as well as any user-specific advice in spoken and written and through tests, are made to best of our knowledge and information about the intended use. However, they are regarded as being only informal and changes are expressly reserved, in particular due to technical changes. This also applies to any violation of industrial property rights of a third-party. Selection of our units in view of their suitability for the intended use must be done generally by the user.

**Tests can only be done within the intended end use of the product (application) by the customer. They must be repeated, even if only parts of hardware, software or the unit adjustment are modified.**

## Copyright

The customer may use the instructions for use as well as further documents or parts from it for internal purposes. Copyrights are with KEB and remain valid in its entirety.

This KEB product or parts thereof may contain third-party software, including free and/or open source software. If applicable, the license terms of this software are contained in the instructions for use. The instructions for use are already available to you, can be downloaded free of charge from the KEB website or can be requested from the respective KEB contact person.

Other wordmarks or/and logos are trademarks (™) or registered trademarks (®) of their respective owners.

# Table of Contents

<b>Preface</b> .....	<b>3</b>
Signal words and symbols .....	3
More symbols.....	3
Laws and guidelines.....	4
Warranty and liability.....	4
Support .....	4
Copyright.....	4
<b>Table of Contents</b> .....	<b>5</b>
<b>1 Basic Safety Instructions</b> .....	<b>9</b>
1.1 Target group.....	9
1.2 Transport, storage and proper use.....	10
1.3 Installation.....	11
1.4 Electrical connection .....	12
1.4.1 EMC-compatible installation.....	13
1.4.2 Voltage test.....	13
1.4.3 Insulation measurement.....	13
1.5 Start-up and operation .....	14
1.6 Maintenance.....	16
1.7 Repair .....	16
1.8 Disposal.....	17
<b>2 Product Description</b> .....	<b>18</b>
2.1 Specified application.....	18
2.1.1 Residual risks .....	18
2.2 Unintended use.....	18
2.3 Product features .....	19
2.4 Part code .....	20
2.5 Nameplate .....	22
2.5.1 Configurable options .....	23
<b>3 Technical data</b> .....	<b>24</b>
3.1 Operating conditions .....	24
3.1.1 Climatic environmental conditions.....	24
3.1.2 Mechanical environmental conditions .....	25
3.1.3 Further environmental operating conditions.....	25
3.1.4 Electrical operating conditions.....	26
3.1.4.1 Device classification .....	26
3.1.4.2 Electromagnetic compatibility.....	26
3.2 Device data of the 230 V devices .....	27
3.2.1 Overview of the 230 V devices.....	27

3.2.2 Voltage and frequencies for 230V devices .....	28
3.2.2.1 Example of the calculation of the possible motor voltage 230V .....	29
3.2.3 Input and output currents / overload for 230 V devices.....	29
3.2.3.1 Overload characteristic (OL) for 230 V devices.....	30
3.2.3.2 Frequency-dependent maximum current (OL2) for 230V devices .....	32
3.2.4 Power dissipation at rated operation for 230V devices.....	35
3.2.5 Fusing of the 230V devices .....	35
<b>3.3 Device data of the 400 V devices .....</b>	<b>36</b>
3.3.1 Overview of the 400V devices.....	36
3.3.2 Voltage and frequencies for 400V devices.....	37
3.3.3 Input and output currents / overload for 400 V devices.....	38
3.3.2.1 Example of the calculation of the possible motor voltage: .....	38
3.3.3.1 Overload characteristic (OL) for 400 V devices.....	39
3.3.3.2 Frequency-dependent maximum current (OL2) for 400V devices .....	41
3.3.4 Overview of rectifier data.....	45
3.3.5 Power dissipation at rated operation for 400V devices .....	46
3.3.6 Fusing of the 400V devices .....	46
3.3.6.1 Fuse protection for AC supply .....	46
3.3.6.2 Protection of 400 V devices with DC power supply.....	47
3.3.6.3 Motor protection switch / circuit breaker.....	48
<b>3.4 General electrical data .....</b>	<b>50</b>
3.4.1 Switching frequency and temperature.....	50
3.4.1.1 Switching frequency and temperature of the 230 V devices .....	50
3.4.1.2 Switching frequency and temperature of the 400 V devices .....	50
3.4.2 DC link / braking transistor.....	51
3.4.2.1 DC link / braking transistor function of the 230V devices .....	52
3.4.2.2 DC link / braking transistor function of the 400V devices .....	53
3.4.3 Fan .....	54
3.4.3.1 Switching behaviour of the fans .....	55
3.4.3.2 Switching points of the fans.....	55
<b>4 Installation.....</b>	<b>56</b>
<b>4.1 Dimensions and weights .....</b>	<b>56</b>
4.1.1 Built-in version air cooler.....	56
4.1.2 Built-in version fluid cooler (water).....	57
4.1.3 Push-through version air cooler IP20, IP54-ready .....	58
4.1.4 Push-through version fluid cooler (water) IP20, IP54-ready.....	59
<b>4.2 Control cabinet installation .....</b>	<b>60</b>
4.2.1 Mounting instructions .....	60
4.2.2 Mounting distances .....	61
4.2.3 Installation of IP54-ready devices .....	62
4.2.4 Control cabinet ventilation.....	63
4.2.5 Airflow of the drive controller .....	63

<b>5</b>	<b>Installation and connection .....</b>	<b>64</b>
5.1	Overview of the COMBIVERT F6.....	64
5.2	Connection of the power unit.....	67
5.2.1	Connection of the voltage supply .....	67
5.2.1.1	Terminal block X1A.....	68
5.2.2	Protective earth and functional earth.....	69
5.2.2.1	Protective earth .....	69
5.2.2.2	Functional earthing.....	69
5.3	Mains connection .....	70
5.3.1	Supply cable.....	70
5.3.2	AC mains connection.....	70
5.3.2.1	AC supply 3-phase .....	70
5.3.2.2	Note on hard power systems.....	71
5.3.3	DC mains connection .....	72
5.3.3.1	Terminal block X1A DC connection .....	72
5.3.3.2	Connection at DC voltage supply .....	73
5.3.4	Connection of the motor .....	74
5.3.4.1	Wiring of the motor .....	74
5.3.4.2	Terminal block X1A motor connection .....	75
5.3.4.3	Selection of the motor line.....	76
5.3.4.4	Motor cable length and conducted interferences at AC supply .....	76
5.3.4.5	Motor cable length for parallel operation of motors .....	77
5.3.4.6	Motor cable cross-section .....	77
5.3.4.7	Interconnection of the motor.....	77
5.3.4.8	Connection of the temperature monitoring and brake control (X1C).....	78
5.3.5	Connection and use of a braking resistor.....	80
5.3.5.1	Terminal block X1A connection braking resistor.....	81
5.3.5.2	Use of intrinsically safe braking resistors .....	82
5.3.5.3	Use of non-intrinsically safe braking resistors.....	82
5.3.6	DC-bus connection.....	83
5.4	Accessories .....	85
5.4.1	Filters and chokes .....	85
5.4.2	Seal for IP54-ready devices .....	85
5.4.3	Mounting kit shield connection brackets.....	85
5.4.4	Side-mounted braking resistors.....	86
<b>6</b>	<b>Operation of Liquid-Cooled Devices.....</b>	<b>87</b>
6.1	Water-cooled devices.....	87
6.1.1	Heat sink and operating pressure .....	87
6.1.2	Materials in the cooling circuit .....	87
6.1.3	Requirements for the coolant .....	88
6.1.4	Connection of the cooling system .....	90

6.1.5 Coolant temperature and moisture condensation .....	91
6.1.5.1 Condensation .....	91
6.1.5.2 Supply of temper coolant.....	91
6.1.6 Permissible volume flow with water cooling .....	92
6.1.7 Coolant heating .....	93
6.1.8 Typical pressure drop of the heat sink.....	94
<b>7 Approvals and certifications .....</b>	<b>95</b>
7.1 CE-Marking.....	95
7.2 UL certification .....	96
7.3 Further informations and documentation.....	98
<b>8 Revision history.....</b>	<b>99</b>
<b>Glossary .....</b>	<b>100</b>
<b>List of Figures.....</b>	<b>102</b>
<b>List of Tables.....</b>	<b>103</b>

# 1 Basic Safety Instructions

The products are designed and constructed in accordance with state-of-the-art technology and the recognized safety rules and regulations. However, the use of such devices may cause functional hazards for life and limb of the user or third parties, or damages to the system and other material property.

The following safety instructions have been created by the manufacturer for the area of electric drive technology. They can be supplemented by local, country- or application-specific safety instructions. This list is not exhaustive. Violation of the safety instructions by the customer, user or other third party leads to the loss of all resulting claims against the manufacturer.

## NOTICE



### Hazards and risks through ignorance!

- ▶ Read the instructions for use!
- ▶ Observe the safety and warning instructions!
- ▶ If anything is unclear, please contact KEB Automation KG!

## 1.1 Target group

This instruction manual is determined exclusively for electrical personnel. Electrical personnel for the purpose of this instruction manual must have the following qualifications:

- Knowledge and understanding of the safety instructions.
- Skills for installation and assembly.
- Start-up and operation of the product.
- Understanding of the function in the used machine.
- Detection of hazards and risks of the electrical drive technology.
- Knowledge of *VDE 0100*.
- Knowledge of national safety regulations.
- 

## ⚠ DANGER



### Interventions by unauthorized personnel!

#### Danger to life by electric shock and malfunction!

- ▶ Modification or repair is only permitted by KEB authorised personnel.

## 1.2 Transport, storage and proper use

The transport is carried out by qualified persons in accordance with the environmental conditions specified in this manual. Drive controller shall be protected against excessive strains.



### Transport of drive controllers with an edge length >75 cm

The transport by forklift without suitable tools can cause a deflection of the heat sink. This leads to premature aging or destruction of internal components.

- ▶ Transport of drive controllers on suitable pallets.
- ▶ Do not stack drive controllers or burden them with other heavy objects.

### NOTICE

#### Damage to the coolant connections

##### Bending of the tubes!

- ▶ Never place the device on the coolant connections

### NOTICE



#### Behaviour in case of transport damage

- ▶ When receiving goods, check the device for transport damage such as deformations or loose parts.
- ▶ In case of damage, contact the carrier immediately.
- ▶ Do not operate the device in case of transport damage!



#### Drive controllers contain electrostatic sensitive components.

- ▶ Avoid contact.
- ▶ Wear ESD-protective clothing.

Do not store drive controllers

- in the environment of aggressive and/or conductive liquids or gases.
- with direct sunlight.
- outside the specified environmental conditions.

### 1.3 Installation

**⚠ DANGER****Do not operate in an explosive environment!**

- ▶ The product is not intended for the use in potentially explosive environment.

**⚠ CAUTION****Design-related edges and high weight!****Contusions and bruises!**

- ▶ Never stand under suspended loads.
- ▶ Wear safety shoes.
- ▶ Secure drive controller accordingly when using lifting gear.

To prevent damages to the device:

- Make sure that no components are bent and/or isolation distances are changed.
- The device must not be put into operation in case of mechanical defects.
- Do not allow moisture or mist to penetrate the unit.
- Avoid dust permeating the device. Allow for sufficient heat dissipation if installed in a dust-proof housing.
- Note installation position and minimum distances to surrounding elements. Do not cover the ventilation openings.
- Mount the drive controller according to the specified degree of protection.
- Make sure that no small parts fall into the product during assembly and wiring (drilling chips, screws etc.). This also applies to mechanical components, which can lose small parts during operation.
- Check the reliable fit of the device connections in order to avoid contact resistances and sparking.
- Do not walk-on drive controller.
- Follow all safety instructions!

## 1.4 Electrical connection

**⚠ DANGER****Voltage at the terminals and in the device !****Danger to life due to electric shock !**

- ▶ Never work on the open device or never touch exposed parts.
- ▶ For any work on the unit switch off the supply voltage, secure it against switching on and check absence of voltage by measuring at the input terminals.
- ▶ Wait until all drives has been stopped in order that no regenerative energy can be generated.
- ▶ Await capacitor discharge time (5 minutes). Check absence of voltage by measuring at the DC terminals.
- ▶ If personal protection is required, install suitable protective devices for drive converters.
- ▶ Never bridge upstream protective devices (even for testing purposes).
- ▶ Connect the protective earth conductor always to drive converter and motor.
- ▶ Install all required covers and protective devices for operation.
- ▶ The control cabinet shall be kept closed during operation.
- ▶ Residual current: This product may cause a dc current in the protective earth conductor. When a residual current protective device (RCD) or a residual current monitoring device (RCM) is used for the protection against direct or indirect contact, only a RCD or RCM type B is permitted on the power supply side of this product.
- ▶ Drive converters with a leakage current  $> 3.5\text{mA AC}$  current (10mA DC current) are intended for a stationary connection. Protective earth conductors must be designed in accordance with the local regulations for equipment with high leakage currents according to *EN 61800-5-1*, *EN 60204-1* or *VDE 0100*.



If personnel protection is required during installation of the system, suitable protective devices must be used for drive controllers.

[www.keb.de/fileadmin/media/Techinfo/dr/tn/ti\\_dr\\_tn-rcd-00008\\_en.pdf](http://www.keb.de/fileadmin/media/Techinfo/dr/tn/ti_dr_tn-rcd-00008_en.pdf)



Installations which include drive controller shall be equipped with additional control and protective devices in accordance with the relevant applicable safety requirements, e.g. act respecting technical equipment, accident prevention rules etc. They must always be complied with, also for drive controller bearing a CE marking.

For a trouble-free and safe operation, please pay attention to the following instructions:

- The electrical installation shall be carried out in accordance with the relevant requirements.
- Cable cross-sections and fuses must be dimensioned by the user according to the specified minimum/maximum values for the application.
- Connection of the drive converter is only permissible on symmetrical networks with a maximum line voltage (L1, L2, L3) with respect to earth (N/PE) of max. 300 V, USA UL: 480 / 277 V. An isolating transformer must be used for supply networks which exceed this value! In case of non-compliance the control is not longer considered to be a PELV circuit.
- With existing or newly wired circuits the person installing the units or machines must ensure that the PELV requirements are met.
- For drive converters that are not isolated from the supply circuit (in accordance with [EN 60721-3-2](#)) all control lines must be included in other protective measures (e.g. double insulation or shielded, earthed and insulated).
- When using components without isolated inputs/outputs, it is necessary that equipotential bonding exists between the components to be connected (e.g. by the equipotential line). Disregard can cause destruction of the components by equalizing currents.

#### 1.4.1 EMC-compatible installation

Observance of the limit values required by EMC law is the responsibility of the customer.



Notes on EMC-compatible installation can be found here.  
[www.keb.de/fileadmin/media/Manuals/dr/emv/0000neb0000.pdf](http://www.keb.de/fileadmin/media/Manuals/dr/emv/0000neb0000.pdf)



#### 1.4.2 Voltage test

Testing with AC voltage (in accordance with [EN 60204-1](#) chapter 18.4) may not be executed, since there is danger for the power semiconductors in the drive controller.



Due to the radio interference suppression capacitors, the test generator will switch off immediately with a current fault.



According to [EN 60204-1](#) it is permissible to disconnect already tested components. Drive controllers of the KEB Automation KG are delivered ex works voltage tested to 100% according to product standard.

#### 1.4.3 Insulation measurement

An insulation measurement (in accordance with [EN 60204-1](#) chapter 18.3) with DC 500 V is permissible, if all power unit connections (grid-connected potential) and all control connections are bridged with PE. The insulation resistance of the respective device can be found in the technical data.

## 1.5 Start-up and operation

The start-up (i.e. for the specified application) is forbidden until it is determined that the installation complies with the machine directive; account is to be taken of [EN 60204-1](#).

### ⚠ WARNING

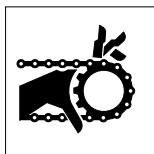

#### Software protection and programming!

##### Hazards caused by unintentional behavior of the drive!

- ▶ Check especially during initial start-up or replacement of the drive controller if parameterization is compatible to application.
- ▶ Securing a unit solely with software-supported functions is not sufficient. It is imperative to install external protective measures (e.g. limit switch) that are independent of the drive controller.
- ▶ Secure motors against automatic restart.

### ⚠ CAUTION



#### High temperatures at heat sink and coolant!

##### Burning of the skin!

- ▶ Cover hot surfaces safe-to-touch.
- ▶ If necessary, attach warning signs on the system.
- ▶ Before touching, check the surface and coolant lines.
- ▶ Before working let the unit cool down.

- During operation, all covers and doors shall be kept closed.
- Use only approved accessories for this device.
- Never touch terminals, busbars or cable ends.

### ⚠ WARNING



#### Triggering of overcurrent protection devices

##### Risk of fire or electric shock!

- ▶ Triggering of an overcurrent protection device will be a hint for an overload or short circuit. Triggering a RCD may be caused by a leakage current.
- ▶ In order to reduce the risk of fire or electric shock, live parts and other components of the controller should be checked and replaced in case of damage.
- ▶ If the contacts of an overload relay are burned, the complete relay must be replaced.

**⚠ CAUTION**

**High sound level during operation!**

**Hearing damage possible!**

- ▶ Wear hearing protection!

**NOTICE**

**Continuous operation (S1) with load > 60% or from a rated motor power of 55kW!**

**Premature ageing of the electrolytic capacitors!**

- ▶ Mains choke with  $U_k = 4\%$  absolutely necessary.



If a drive controller with electrolytic capacitors in a DC link has not been in operation for more than one year, observe the following instructions.

[www.keb.de/fileadmin/media/Techinfo/dr/tn/ti\\_dr\\_tn-format-capacitors-00009\\_en.pdf](http://www.keb.de/fileadmin/media/Techinfo/dr/tn/ti_dr_tn-format-capacitors-00009_en.pdf)

**Switching at the output**

Switching between motor and drive controller is prohibited for single drives during operation as this may trigger the protection gear of the device. Function 'speed search' must be activated if switching can not be avoided. Speed search may only be triggered after closing the motor contactor (e.g. by switching the control release).

Connecting and disconnecting is permissible with multiple motor drives if at least 1 motor is running during the switch-over process. The drive controller must be dimensioned to the occurring starting currents.

The 'speed search' function must be activated if the motor is still running during a restart of the drive controller (mains on) (e.g. due to large rotating masses).

**Switching at the input**

For applications that require cyclic switching off and on of the drive controller, maintain an off-time of at least 5 min after the last switch on. If you require shorter cycle times please contact KEB Automation KG.

**Short-circuit resistance**

The drive converters are conditional short-circuit proof. After resetting the internal protection devices, the function as directed is guaranteed.

Exceptions:

- If an earth-leakage fault or short-circuit often occurs at the output, this can lead to a defect in the unit.
- If a short-circuit occurs during regenerative operation (2nd or 4th quadrant, regeneration into the DC link), this can lead to a defect in the unit.

## 1.6 Maintenance

The following maintenance work has to be carried out when required, but at least once per year by authorized and trained personnel. Check unit for loose screws and plugs and tighten if necessary.

- ▶ Check system for loose screws and plugs and tighten if necessary.
- ▶ Clean drive controller from dirt and dust deposits. Pay attention especially to cooling fins and protective grid of the fans.
- ▶ Examine and clean extracted air filter and cooling air filter of the control cabinet.
- ▶ Check the function of the fans of the drive controller. The fan must be replaced in case of audible vibrations or squeak.
- ▶ In the case of liquid-cooled drive controllers a visual test of the cooling circuit for leaks and corrosion must be carried out. The cooling circuit must be completely empty if a unit shall be switched off for a longer period. The cooling circuit must be blown out additionally with compressed air at temperatures below 0°C.

## 1.7 Repair

In case of malfunction, unusual noises or smells inform a person in charge!

**⚠ DANGER**



**Unauthorized exchange, repair and modifications!**

**Unpredictable malfunctions!**

- ▶ The function of the drive controller is dependent on its parameterization. Never replace without knowledge of the application.
- ▶ Modification or repair is permitted only by KEB Automation KG authorized personnel.
- ▶ Only use original manufacturer parts.
- ▶ Infringement will annul the liability for resulting consequences.

In case of failure, please contact the machine manufacturer. Only the machine manufacturer knows the parameterisation of the used drive controller and can provide an appropriate replacement or induce the maintenance.

## 1.8 Disposal

Electronic devices of the KEB Automation KG are exclusively professional devices for further industrial processing (so-called B2B devices).

Manufacturers of B2B devices are obliged to take back and recycle devices manufactured after 14.08.2018. These devices may not be disposed at the collection centres of public sector disposal organisations.

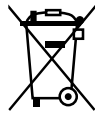

If no deviating agreement has been made between the customer and KEB or no deviating mandatory legal regulation exists, KEB products marked in this way can be returned. Company and keyword to the return point can be taken from the list below. Shipping costs are paid by the customer. Thereupon the devices will be professionally recycled and disposed.

The entry numbers are listed country-specific in the following table. The corresponding KEB return addresses can be found on our website.

Withdrawal by	WEEE-Reg.-No.	Keyword
<b>Austria</b>		
KEB Automation GmbH	ERA: 51976	Stichwort „Rücknahme WEEE“
<b>France</b>		
RÉCYLUM - Recycle point	ADEME: FR021806	Mots clés „KEB DEEE“
<b>Germany</b>		
KEB Automation KG	EAR: DE12653519	Stichwort „Rücknahme WEEE“
<b>Italy</b>		
COBAT	AEE: (IT) 19030000011216	Parola chiave „Ritiro RAEE“
<b>Spain</b>		
KEB Automation KG	RII-AEE 7427	Palabra clave „Retirada RAEE“
<b>Česko</b>		
KEB Automation KG	RETELA 09281/20 ECZ	Klíčové slovo: Zpětný odběr OEEZ
<b>Slowakei</b>		
KEB Automation KG	ASEKOL: RV22EEZ0000421	Klíčové slovo: "Spätňý odber OEEZ"

The packaging must be feed to paper and cardboard recycling.

## 2 Product Description

The device series COMBIVERT F6 concerns to drive controllers, which are optimized for operation at synchronous and asynchronous motors.

The COMBIVERT can be extended with a safety module for the use in safety-oriented applications. The COMBIVERT F6 series are drive controllers with functional safety, optimized for operation at synchronous and asynchronous motors.

Various safety functions are available for different applications. It can be operated with a fieldbus module at different fieldbus systems. The control board has a system comprehensive operating concept.

The COMBIVERT complies with the requirements of the Machinery Directive. The possible functions are certified via a type test.

The COMBIVERT is a product of limited availability in accordance with [EN 61800-3](#). This product may cause radio interference in residential areas. In this case the operator may need to take corresponding measures.

The Machinery Directive, EMC Directive, Low Voltage Directive and other directives and regulations must be observed

### 2.1 Specified application

The COMBIVERT serves exclusively for the control and regulation of three-phase motors. It is intended for the installation into electrical systems or machines in the industrie.

Technical data and information for connection conditions shall be taken from the nameplate and from the instructions for use and must be strictly observed.

The used semiconductors and components of the KEB Automation KG are developed and dimensioned for the use in industrial products.

#### **Restriction**

If the product is used in machines, which work under exceptional conditions or if essential functions, life-supporting measures or an extraordinary safety step must be fulfilled, the necessary reliability and security must be ensured by the machine builder.

#### 2.1.1 Residual risks

Despite intended use, the drive controller can reach unexpected operating conditions in case of error, with wrong parameterization, by faulty connection or unprofessional interventions and repairs. This can be:

- wrong direction of rotation
- motor speed too high
- motor is running into limitation
- motor can be under voltage even in standstill
- automatic start

### 2.2 Unintended use

The operation of other electric consumers is prohibited and can lead to the destruction of the devices. The operation of our products outside the indicated limit values of the technical data leads to the loss of any liability claims.

## 2.3 Product features

These instructions for use describe the power units of the following devices:

Device type:	Drive controller
Series:	COMBIVERT F6
Power range:	11...18.5 kW / 230V 18.5...37 kW / 400V
Housing:	3

The COMBIVERT F6 is characterized by the following features:

- Operation of three-phase asynchronous motors and three-phase synchronous motors, in operating modes open-loop or closed-loop with and without speed feedback
- Following fieldbus systems are supported:  
EtherCAT, VARAN, PROFINET, POWERLINK or CAN
- System-overlapping operating concept
- Wide operating temperature range
- Low switching losses by IGBT power unit
- Low noise development due to high switching frequencies
- Different heat sink concepts
- Temperature-controlled fan, easily replaceable
- Torque limits and s-curves are adjustable to protect gearboxes
- General protection functions of the COMBIVERT series against overcurrent, over-voltage, ground fault and overtemperature
- Analog inputs and outputs, digital inputs and outputs, relay output (potential-free), brake control and -supply, motor protection by I<sup>2</sup>t, KTY- or PTC input, two encoder interfaces, diagnostic interface, fieldbus interface (depending on the control board)
- Integrated safety function according to [EN 61800-5-2](#)

2.4 Part code

x x F 6 x x x - x x x x

Heat sink version

1: Air-cooler, mounted version
2: Liquid cooler (water), mounted version
3: Air-cooler, through-mount version IP54-ready
4: Liquid cooler (water), through-mount version IP54-ready
5: Air-cooler, through-mount version IP20
6: Liquid cooler (water), trough-mount version IP54-ready, sub-mounted braking resistors
7: Liquid cooler (oil), through-mount version IP54-ready
8: Liquid cooler (oil), through-mount version IP54-ready, sub-mounted braking resistors
9: Liquid cooler (water), mounted version, sub-mounted braking resistors
A: Liquid cooler (water), mounted version, High Performance, sub-mounted braking resistors
B: Liquid cooler (water), through-mount version, IP54-ready, High Performance, sub-mounted braking resistors
C: Air-cooler, mounted version, Version 2
D: Air-cooler, mounted version, High-Performance
E: Liquid cooler (water), mounted version, High-Performance
F: Air-cooler, through-mount version IP54-ready, High-Performance
G: Liquid cooler (water), trough-mount version IP54-ready, High-Performance
H: Air-cooler,, Convektion, trough-mount version IP54-ready

Control board variant

<b>APPLIKATION</b>
1: Multi Encoder Interface, CAN <sup>® 2)</sup> , Real-Time Ethernet-busmodule <sup>3)</sup>
B: Multi Encoder Interface, CAN <sup>® 2)</sup> , Real-Time Ethernet-busmodule <sup>3)</sup> , Alternative connector
<b>KOMPAKT</b>
1: Multi Encoder Interface, CAN <sup>® 2)</sup> , STO, EtherCAT <sup>® 1)</sup>
2: Multi Encoder Interface, CAN <sup>® 2)</sup> , STO, VARAN
<b>PRO</b>
0: No Encoder, CAN <sup>® 2)</sup> , Real-Time Ethernetinterface <sup>3)</sup>
1: Multi Encoder Interface, CAN <sup>® 2)</sup> , Real-Time Ethernet interface <sup>3)</sup>
3: Multi Encoder Interface, CAN <sup>® 2)</sup> , Real-Time Ethernet interface <sup>3)</sup> , RS485-potential free
4: No Encoder, CAN <sup>® 2)</sup> , Real-Time Ethernetinterface <sup>3)</sup> , safe relay
5: Multi Encoder Interface, CAN <sup>® 2)</sup> , Real-Time Ethernet interface <sup>3)</sup> , safety relay
B: Multi Encoder Interface, CAN <sup>® 2)</sup> , Real-Time Ethernet interface <sup>3)</sup> , alternative connector

*continued on the next page*

x x	F 6	x	x	x	-x	x	x	x
		Switching frequency, Software current limit, Turn-off current		0: 2 kHz / 125% / 150%	8: 2 kHz / 180% / 216%			
				1: 4 kHz / 125% / 150%	9: 4 kHz / 180% / 216%			
				2: 8 kHz / 125% / 150%	A: 8 kHz / 180% / 216%			
				3: 16 kHz / 125% / 150%	B: 8 kHz / HSD			
				4: 2 kHz / 150% / 180%	C: 6 kHz / HSD			
				5: 4 kHz / 150% / 180%	Non standard switching		D: frequency / Overload characteristic	
				6: 8 kHz / 150% / 180%	E: Special Device			
				7: 16 kHz / 150% / 180%				
		Voltage / Connection type		1: 3ph 230 V AC/DC with braking transistor				
				2: 3ph 230 V AC/DC without braking transistor				
				3: 3ph 400 V AC/DC with braking transistor				
				4: 3ph 400 V AC/DC without braking transistor				
				A: 3ph 400 V AC/DC incl. GTR7 / max. rectifier / max. pre-charging				
				B: 3ph 400 V AC/DC without GTR7 / max. rectifier / max. pre-charging				
				C: 3ph 400 V AC/DC. GTR7-variant 2				
				D: 3ph 400 V AC/DC GTR7-variant 2 / max. rectifier / max. pre-charging				
		Housing		2...9				
		Equipment		1: Safety module type 1 /STO at control type K				
				3: Safety module type 3				
				4: Safety module type 4				
				5: Safety module type 5				
		Control type		A: APPLICATION				
				K: COMPACT				
				P: PRO				
		Series		COMBIVERT F6				
		Inverter size		10...33				

Table 1: Part code

- 1) EtherCAT® is registered trademark and patented technology, licensed by Beckhoff Automation GmbH, Germany
- 2) CANopen® is registered trademark of CAN in AUTOMATION - International Users and Manufacturers Group e.V.
- 3) The Real-Time Ethernetbusmodul / Real-Time Ethernet interface contains various fieldbus control types which can be adjusted by software (parameter fb68)



The part code may not be used as order code, but only for identification!

## 2.5 Nameplate

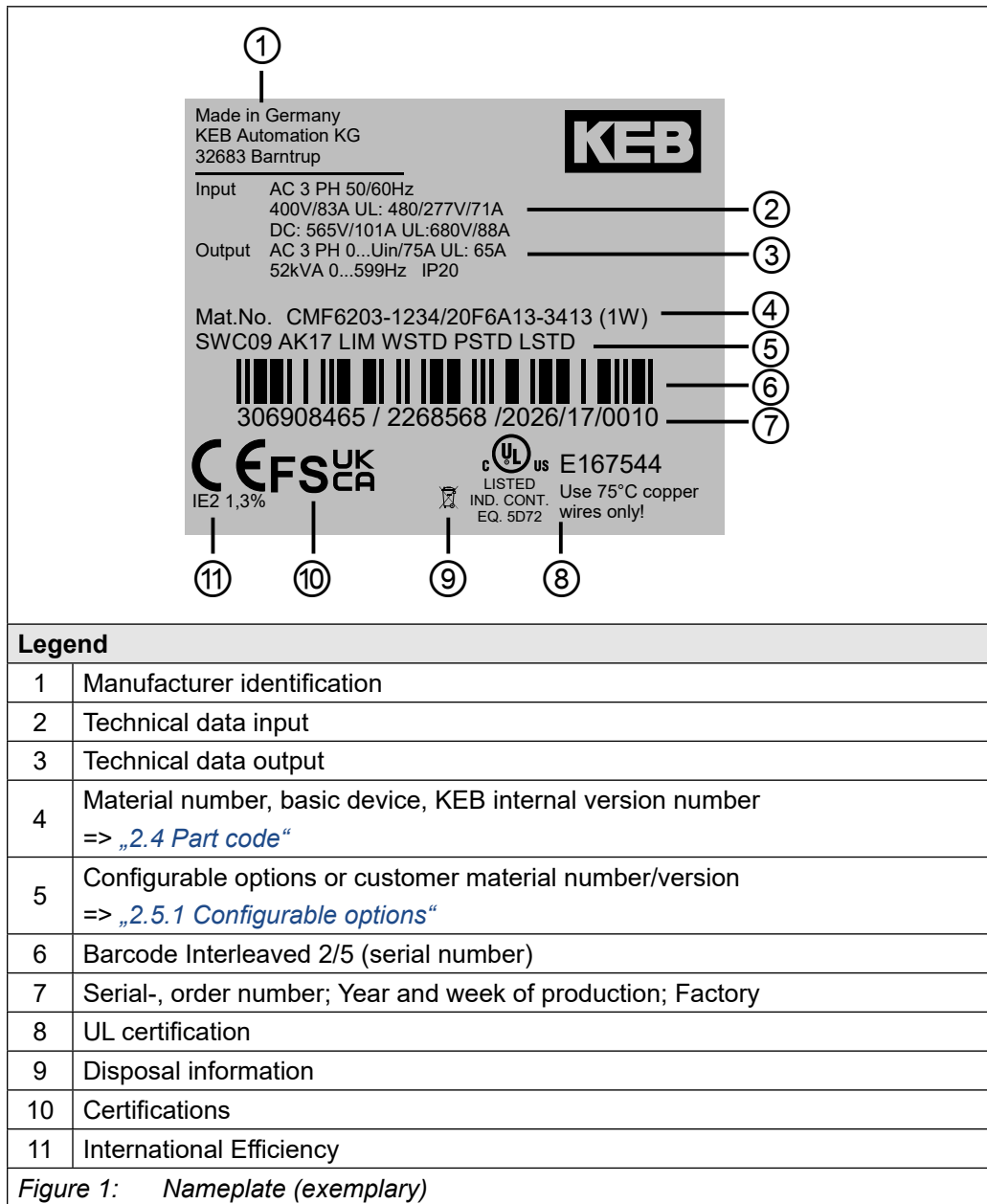

2.5.1 Configurable options

Features	Feature values	Description
Software	SWxxx <sup>1)</sup>	Software status of the drive controller
Accessories	Axxx <sup>1)</sup>	Selected accessories
	NAK	No accessories
Output frequency activation	LIM	Limitation to 599 Hz
	ULO	> 599 Hz activated
Warranty	WSTD	Warranty - Standard
	Wxxx <sup>1)</sup>	Warranty extension
Parameterization	PSTD	Parameterization - Standard
	Pxxx <sup>1)</sup>	Parameterization - Customer-specific
Nameplate logo	LSTD	Logo - Standard
	Lxxx <sup>1)</sup>	Logo - Customer-specific
<i>Figure 2: Configurable options</i>		

<sup>1)</sup> „x“ indicates a variable value

### 3 Technical data

Unless otherwise indicated, all electrical data in the following chapter refer to a 3-phase AC mains.

#### 3.1 Operating conditions

##### 3.1.1 Climatic environmental conditions

Storage		Standard	Class	Descriptions
Ambient temperature		EN 60721-3-1	1K4	-25...55 °C
Relative humidity		EN 60721-3-1	1K3	5...95 % (without condensation)
Storage height		–	–	Max. 3000 m above sea level
Transport		Standard	Class	Descriptions
Ambient temperature		EN 60721-3-2	2K3	-25...70 °C
Relative humidity		EN 60721-3-2	2K3	95 % at 40 °C (without condensation)
Operation		Standard	Class	Descriptions
Ambient temperature		EN 60721-3-3	3K3	5...40 °C (extended to -10...45 °C)
Coolant inlet temperature	Air	–	–	5...40 °C (extended to -10...45 °C)
Relative humidity		EN 60721-3-3	3K3	5...85 % (without condensation)
Version and degree of protection		EN 60529	IP20	Protection against foreign material > ø12.5 mm No protection against water Non-conductive pollution, occasional condensation when PDS is out of service. Drive controller generally, except power connections and fan unit (IPxxA)
Site altitude		–	–	Max. 2000 m above sea level • With site altitudes over 1000 m a derating of 1 % per 100 m must be taken into consideration. • With site altitudes over 2000 m, the control board to the mains has only basic isolation. Additional measures must be taken when wiring the control.

Table 2: Climatic environmental conditions

**3.1.2 Mechanical environmental conditions**

Storage	Standard	Class	Descriptions
Vibration limits	<a href="#">EN 60721-3-1</a>	1M2	Vibration amplitude 1.5 mm (2...9 Hz) Acceleration amplitude 5 m/s <sup>2</sup> (9...200 Hz)
Shock limit values	<a href="#">EN 60721-3-1</a>	1M2	40 m/s <sup>2</sup> ; 22 ms
Transport	Standard	Class	Descriptions
Vibration limits	<a href="#">EN 60721-3-2</a>	2M1	Vibration amplitude 3.5 mm (2...9 Hz) Acceleration amplitude 10 m/s <sup>2</sup> (9...200 Hz)
Shock limit values	<a href="#">EN 60721-3-2</a>	2M1	100 m/s <sup>2</sup> ; 11 ms
Operation	Standard	Class	Descriptions
Vibration limits	<a href="#">EN 60721-3-3</a>	3M4	Vibration amplitude 3.0 mm (2...9 Hz) Acceleration amplitude 10 m/s <sup>2</sup> (9...200 Hz)
	<a href="#">EN 61800-5-1</a>	–	Vibration amplitude 0.075 mm (10...5 Hz) Acceleration amplitude 10 m/s <sup>2</sup> (57...150 Hz)
Shock limit values	<a href="#">EN 60721-3-3</a>	3M4	100 m/s <sup>2</sup> ; 11 ms

*Table 3: Mechanical environmental conditions*

**3.1.3 Further environmental operating conditions**

Operation	Standard	Class	Descriptions
Chemically active substances	<a href="#">EN 60721-3-3</a>	3C2	No salt spray
Mechanically active substances		3S2	–
Organic		3B1	–
UV resistance	<a href="#">EN 61800-5-1</a>	–	No requirement

*Table 4: Further environmental operating conditions*

**3.1.4 Electrical operating conditions**

3.1.4.1 Device classification

Requirement	Standard	Class	Descriptions
Overtoltage category	<a href="#">EN 61800-5-1</a>	III	–
Pollution degree	<a href="#">EN 61800-5-1</a>	2	Non-conductive pollution, occasional condensation when PDS is out of service

Table 5: Device classification

3.1.4.2 Electromagnetic compatibility

For devices without an internal filter, an external filter is required to comply with the following limits.

EMC emitted interference	Standard	Class	Descriptions
Conducted interference emission	<a href="#">EN 61800-3</a>	C2 / C3	The specified value is only maintained in connection with a filter. Information on interference suppression (rated switching frequency, max. motor cable length) can be found in the corresponding filter instructions.
Radiated emitted interference	<a href="#">EN 61800-3</a>	C2	–
EMF	<a href="#">EN 61800-5-1</a>	–	Table P.2
Immunity	Standard	Level	Descriptions
Static discharges	<a href="#">EN 61000-4-2</a>	8 kV 4 kV	AD (air discharge) CD (contact discharge)
Burst - Ports for process measurement control lines and signal interfaces	<a href="#">EN 61000-4-4</a>	2 kV	–
Burst - AC - Power ports	<a href="#">EN 61000-4-4</a>	4 kV	–
Surge - Power ports	<a href="#">EN 61000-4-5</a>	1 kV 2 kV	Phase-phase Phase-ground
Conducted immunity, induced by high-frequency fields	<a href="#">EN 61000-4-6</a>	10 V	0.15...80 MHz
Electromagnetic fields	<a href="#">EN 61000-4-3</a>	10 V/m 3 V/m 1 V/m	80 MHz...1 GHz 1.4...2 GHz 2...2.7 GHz
voltage dips	<a href="#">EN 61000-4-11</a> <a href="#">EN 61000-4-34</a>	Class 3	–
frequency fluctuations	<a href="#">EN 61000-4-28</a>	± 2 %	–
Voltage unbalances	<a href="#">EN 61000-2-4</a>	≤ 3 %	–

Table 6: Electromagnetic compatibility

## 3.2 Device data of the 230 V devices

### 3.2.1 Overview of the 230 V devices

The technical data are for 2/4-pole standard motors. With other pole numbers the drive controller must be dimensioned onto the rated motor current. Contact KEB for special or medium frequency motors.

Device size		15	16	17
<b>Housing</b>		<b>3</b>		
Rated apparent output power	$S_{out}$ / kVA	19	25	30
Max. rated motor power	<sup>1)</sup> $P_{mot}$ / kW	11	15	18,5
Rated input voltage	$U_N$ / V	230 (UL: 240)		
Input voltage range	$U_{in}$ / V	170...264		
Mains phases		3		
Mains frequency	$f_N$ / Hz	50 / 60 ±2		
Rated input current @ $U_N = 230V$	$I_{in}$ / A	57	68	82
Rated input current @ $U_N = 240V$	$I_{in\_UL}$ / A	57	68	82
Insulation resistance @ $U_{dc} = 500V$	$R_{iso}$ / MΩ	> 20		
Output voltage	$U_{out}$ / V	0... $U_{in}$		
Output frequency	<sup>2)</sup> $f_{out}$ / Hz	0...599		
Output phases		3		
Rated output current @ $U_N = 230V$	$I_N$ / A	48	62	75
Rated output current @ $U_N = 240V$	$I_{N\_UL}$ / A	48	62	75
Rated output overload (60 s)	<sup>3) 4)</sup> $I_{60s}$ / %	150		
Software current limit	<sup>3)</sup> $I_{lim}$ / %	150		
Overcurrent	<sup>3)</sup> $I_{OC}$ / %	180		
Rated switching frequency	$f_{SN}$ / kHz	4	4	4
Max. switching frequency	<sup>5)</sup> $f_{S\_max}$ / kHz	16		
Power dissipation at rated operation	<sup>1)</sup> $P_D$ / W	397	533	667
Overload current over time	<sup>3)</sup> $I_{OL}$ / %	„3.2.3.1 Overload characteristic (OL) for 230 V devices“		
Maximum current 0Hz/50Hz at $f_s = 2$ kHz	$I_{out\_max}$ / %	158 / 180	160 / 180	132 / 180
Maximum current 0Hz/50Hz at $f_s = 4$ kHz	$I_{out\_max}$ / %	123 / 180	127 / 180	105 / 180
Maximum current 0Hz/50Hz at $f_s = 8$ kHz	$I_{out\_max}$ / %	79 / 180	87 / 180	72 / 169
Maximum current 0Hz/50Hz at $f_s = 16$ kHz	$I_{out\_max}$ / %	35 / 111	45 / 127	37 / 105
<i>continued on the next page</i>				

## DEVICE DATA OF THE 230 V DEVICES

Device size	15	16	17
<b>Housing</b>	<b>3</b>		
Max. braking current	$I_{B\_max} / A$	76	
Min. braking resistor value	$R_{B\_min} / \Omega$	6	
Braking transistor	<sup>6)</sup>	Max. cycle time: 120s; Max c.d.f.: 50%	
Protective function for braking transistor		Short-circuit monitoring	
Protection function braking transistor (Error GTR7 always on)	<sup>7)</sup>	Feedback signal evaluation and current shutdown	
Max. motor cable length shielded	<sup>8)</sup> // m	100	

Table 7: Overview of the 230 V device data

- <sup>1)</sup> Rated operation corresponds  $U_N = 230 V$ , rated switching frequency, output frequency = 50 Hz (4-pole stand-ard asynchronous motor).
- <sup>2)</sup> The output frequency is to be limited in such a way that it does not exceed 1/10 of the switching frequency. Notice! Devices with a maximum output frequency higher than 599Hz are subject to export restrictions.
- <sup>3)</sup> The values refer in % to the rated output current  $I_N$ .
- <sup>4)</sup> Observe limitations „3.2.3.1 Overload characteristic (OL) for 230 V devices“.
- <sup>5)</sup> A detailed description of the derating „3.4.1.1 Switching frequency and temperature of the 230 V devices“.
- <sup>6)</sup> The cyclic duration factor is additionally limited by the used braking resistor.
- <sup>7)</sup> The feedback signal evaluation monitors the functionality of the braking transistor. The current is switched off via the internal mains input bridge of the AC supply.
- <sup>8)</sup> The maximum cable length depends on various factors. Further information can be found in the correspond-ing filter instructions.

### 3.2.2 Voltage and frequencies for 230V devices

Input voltages and frequencies		
Rated input voltage	$U_N / V$	230
Rated mains voltage (USA)	$U_{N\_UL} / V$	240
Input voltage range	$U_{IN} / V$	170...264
Input phases		3
Mains frequency	$f_N / Hz$	50/60
Mains frequency tolerance	$\pm f_N / Hz$	2

Table 8: Input voltages and frequencies of the 230V devices

DC link voltage		
DC link rated voltage @ $U_N = 400V$	$U_{N\_dc} / V$	325
DC link rated voltage @ $U_{N\_UL} = 480V$	$U_{N\_UL\_dc} / V$	339
DC link voltage working voltage range	$U_{IN\_dc} / V$	240...373

Table 9: DC link voltage for 230V devices

Output voltages and frequencies		
Output voltage at AC supply	<sup>1)</sup> $U_{out} / V$	0... $U_{in}$
Output frequency	<sup>2)</sup> $f_{out} / Hz$	0...599
Output phase		3

Table 10: Output voltages and frequencies of the 230V devices

- <sup>1)</sup> The voltage to the motor is dependent on the actual input voltage and the control method („3.2.2.1 Example of the calculation of the possible motor voltage 230V“).
- <sup>2)</sup> The output frequency is to be limited in such a way that it does not exceed 1/10 of the switching frequency. Devices with a maximum output frequency higher than 599Hz are restricted for exportt.

3.2.2.1 Example of the calculation of the possible motor voltage 230V

The motor voltage for dimensioning of the drive is depending on the used components. The motor voltage reduces according to the following table.

Component	Reduction / %	Example
Mains choke $U_k$	4	Example: Open-loop drive controller with mains- and motor choke at non-rigid supply system: 230 V mains voltage - 11 % = 204,7 V motor voltage
Drive controller open-loop	4	
Drive controller closed-loop	8	
Motor choke $U_k$	1	
Non-rigid supply system	2	

Table 11: Example of the calculation of the possible motor voltage 230V

3.2.3 Input and output currents / overload for 230 V devices

Device size		15	16	17
Rated input current @ $U_N = 230 V$	<sup>1)</sup> $I_{in} / A$	57	68	82
Rated input current @ $U_{N\_UL} = 240 V$	<sup>1)</sup> $I_{in\_UL} / A$	57	68	82
Rated output current @ $U_N = 230 V$	$I_N / A$	48	62	75
Rated output current @ $U_{N\_UL} = 240 V$	$I_{N\_UL} / A$	48	62	75
Rated output overload (60 s)	<sup>2)</sup> $I_{60s} / \%$	150	150	150
Overload current	<sup>2)</sup> $I_{OL} / \%$	=> „3.2.3.1 Overload characteristic (OL) for 230 V devices“		
Software current limit	<sup>2) 3)</sup> $I_{lim} / \%$	150	150	150
Overcurrent	<sup>2)</sup> $I_{OC} / \%$	180	180	180

Table 12: Input currents of the 230 V devices

- <sup>1)</sup> The values resulting from rated operation with B6 rectifier circuit and mains choke 4%  $U_k$ .
- <sup>2)</sup> The values refer in % to the rated output current  $I_N$ .
- <sup>3)</sup> Limitation of the current setpoint in closed-loop operation. This setpoint limit is not active in v/f operation.

### 3.2.3.1 Overload characteristic (OL) for 230 V devices

All drive controllers can be operated at rated switching frequency with an utilisation of 150 % for 60s.

The OL overload function is a root mean square (RMS) function.

The greater the difference between the overload and underload phases, the greater the deviation of the RMS from the arithmetic mean value.

For extreme overloads (=> „*Figure 3: Switch-off time  $t$  depending on the overload  $I/I_N$  (OL)*“), the load is weighted more heavily. This means the load is provided with a factor for the calculation of the RMS value, by way that the overload protection function triggers, even if the RMS value does not reach 100%.

#### **Restrictions:**

- The thermal design of the heat sink is based on the rated operation. The following values are taken into account: Rated output current, ambient temperature, rated switching frequency, rated voltage.
- At high ambient temperatures and/or high heat sink temperatures (for example, by preceding utilisation nearby 100%) the drive controller can change to overtemperature error before triggering the protective function OL.
- At low output frequencies or switching frequencies higher than the rated switching frequency, the frequency-dependent maximum current can be exceeded before and error OL2 can be triggered  
=> „*3.2.3.2 Frequency-dependent maximum current (OL2) for 230V devices*“.

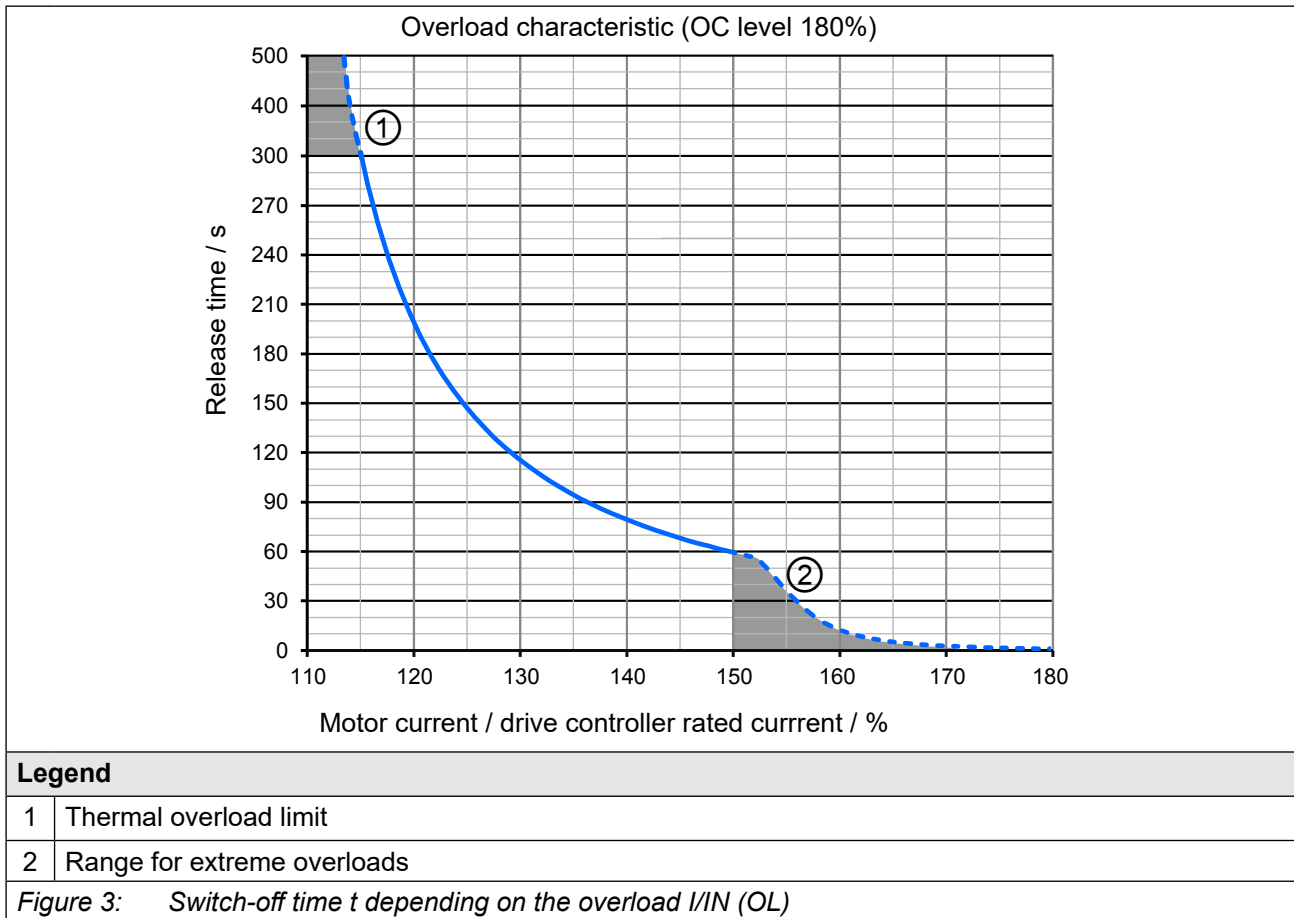

- On exceeding a load of 105 % the overload integrator starts.
- When falling below the integrator counts backwards.
- If the integrator reaches the overload characteristic "Error! overload (OL)" is triggered.

After a cooling down period, the integrator can be reset now. The drive controller must remain switched on during the cooling down phase.

**Operation in the range of the thermal overload limit**

Due to the high steepness of the overload characteristic, the duration of a permissible overload in this range ① cannot be determined exactly. Therefore, the design of the drive controller should be assumed to have a maximum overload time of 300s.

3.2.3.2 Frequency-dependent maximum current (OL2) for 230V devices

The characteristics of the maximum currents for a switching frequency which are depending on the output frequency are different for each drive controller, but the following rules are generally applicable:

- Applies for the rated switching frequency: At 0 Hz output frequency the drive controller can provide at least the rated output current.
- Lower maximum currents apply for switching frequencies > rated switching frequency.

If error (OL2) shall be triggered on exceeding the maximum currents or if the switching frequency is automatically reduced (derating) can be adjusted in the drive controller parameters.

The following characteristic curve indicates the permissible maximum current for the output frequency values 0 Hz, 3 Hz, 6 Hz, 12.5 Hz, 25 Hz and 50 Hz. Device size 17 is represented exemplary (with 2 kHz rated switching frequency).

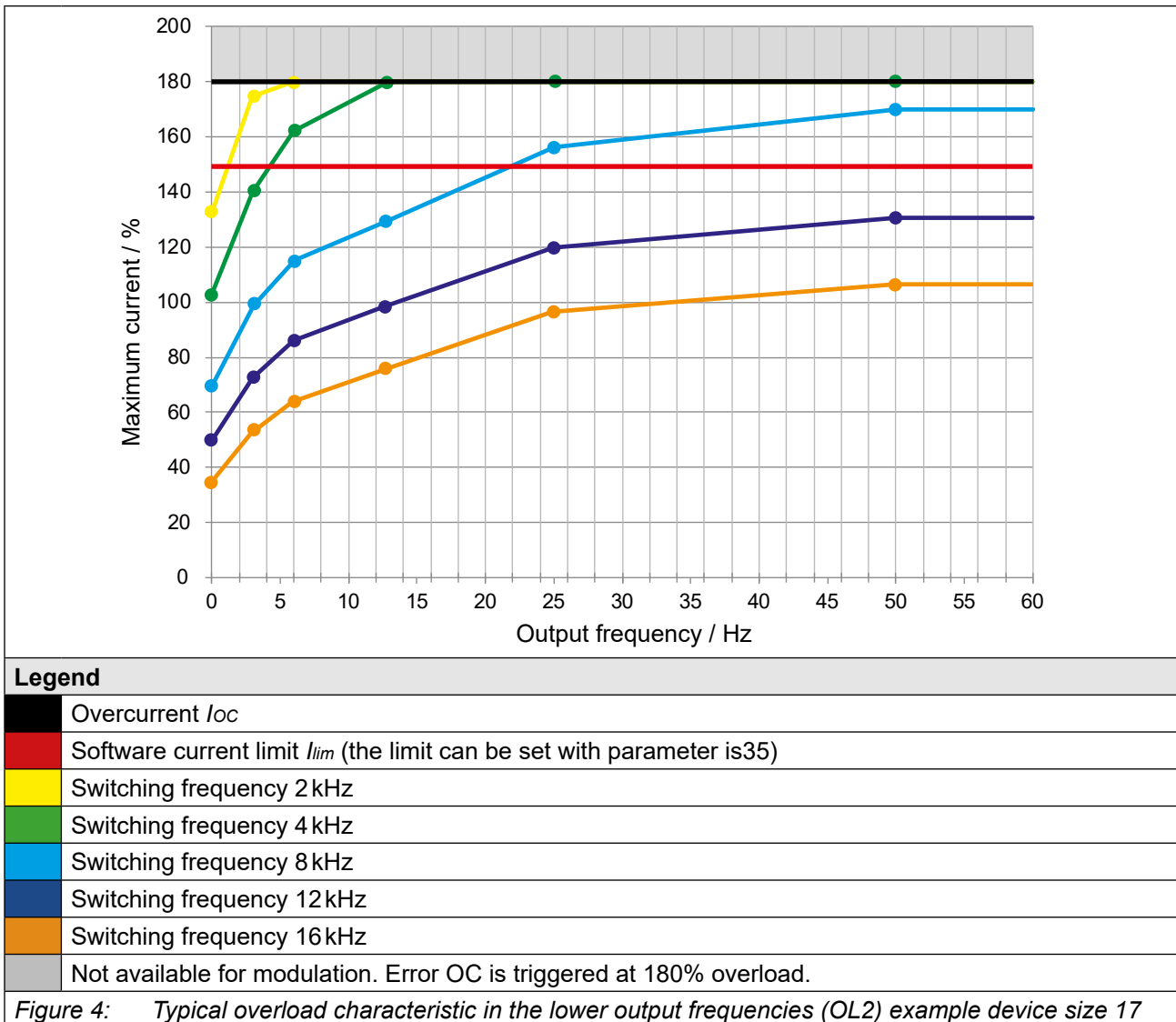

Figure 4: Typical overload characteristic in the lower output frequencies (OL2) example device size 17



The frequency-dependent maximum current  $I_{out\_max} / \%$  refers in % to the rated output current  $I_N$ .

The current remains constant from the last specified output frequency value.



The values for the respective device size are listed in the following tables.

**Frequency-dependent maximum current**

Device size	15						
Rated switching frequency	4 kHz						
Output frequency	$f_{out}$ / Hz	0	3	6	12,5	25	50
<b>Frequency-dependent maximum current @ <math>f_s</math></b> $i_{out\_max}$ % <i>Basic Time Period = 62.5 <math>\mu</math>s (Parameter is22=0)</i>	2 kHz	158	180	180	180	180	180
	4 kHz	123	169	180	180	180	180
	8 kHz	79	113	133	158	180	180
	16 kHz	35	56	69	85	104	117
<b>Frequency-dependent maximum current @ <math>f_s</math></b> $i_{out\_max}$ % <i>Basic Time Period = 71.4 <math>\mu</math>s (Parameter is22=1)</i>	1.75 kHz	158	180	180	180	180	180
	3.5 kHz	132	180	180	180	180	180
	7 kHz	90	127	149	176	180	180
	14 kHz	44	68	81	100	120	133
<b>Frequency-dependent maximum current @ <math>f_s</math></b> $i_{out\_max}$ % <i>Basic Time Period = 83.3 <math>\mu</math>s (Parameter is22=2)</i>	1.5 kHz	158	180	180	180	180	180
	3 kHz	141	180	180	180	180	180
	6 kHz	101	141	165	180	180	180
	12 kHz	52	79	94	115	135	150
<b>Frequency-dependent maximum current @ <math>f_s</math></b> $i_{out\_max}$ % <i>Basic Time Period = 100 <math>\mu</math>s (Parameter is22=3)</i>	1.25 kHz	158	180	180	180	180	180
	2.5 kHz	150	180	180	180	180	180
	5 kHz	112	155	180	180	180	180
	10 kHz	66	96	114	137	159	175

Table 13: Frequency-dependent maximum current for device size 15

Device size		16					
Rated switching frequency		4 kHz					
Output frequency	$f_{out}$ / Hz	0	3	6	12,5	25	50
<b>Frequency-dependent maximum current @ <math>f_s</math></b> <i>Basic Time Period = 62.5 <math>\mu</math>s (Parameter is22=0)</i>	2 kHz	160	180	180	180	180	180
	4 kHz	127	171	180	180	180	180
	8 kHz	87	121	140	157	180	180
	16 kHz	45	66	79	92	116	127
<b>Frequency-dependent maximum current @ <math>f_s</math></b> <i>Basic Time Period = 71.4 <math>\mu</math>s (Parameter is22=1)</i>	1.75 kHz	160	180	180	180	180	180
	3.5 kHz	136	180	180	18	180	180
	7 kHz	97	134	154	172	180	180
	14 kHz	53	77	92	106	131	143
<b>Frequency-dependent maximum current @ <math>f_s</math></b> <i>Basic Time Period = 83.3 <math>\mu</math>s (Parameter is22=2)</i>	1.5 kHz	160	180	180	180	180	180
	3 kHz	144	180	180	180	180	180
	6 kHz	107	146	169	180	180	180
	12 kHz	61	89	105	119	145	158
<b>Frequency-dependent maximum current @ <math>f_s</math></b> <i>Basic Time Period = 100 <math>\mu</math>s (Parameter is22=3)</i>	1.25 kHz	160	180	180	180	180	180
	2.5 kHz	151	180	180	180	180	180
	5 kHz	117	159	180	180	180	180
	10 kHz	74	105	123	138	167	180

Table 14: Frequency-dependent maximum current for device size 16

Device size		17					
Rated switching frequency		4 kHz					
Output frequency	$f_{out}$ / Hz	0	3	6	12,5	25	50
<b>Frequency-dependent maximum current @ <math>f_s</math></b> <i>Basic Time Period = 62.5 <math>\mu</math>s (Parameter is22=0)</i>	2 kHz	132	175	180	180	180	180
	4 kHz	105	141	163	180	180	180
	8 kHz	72	100	116	129	156	169
	16 kHz	37	55	65	76	96	105
<b>Frequency-dependent maximum current @ <math>f_s</math></b> <i>Basic Time Period = 71.4 <math>\mu</math>s (Parameter is22=1)</i>	1.75 kHz	132	175	180	180	180	180
	3.5 kHz	112	150	172	180	180	180
	7 kHz	90	110	128	142	170	180
	14 kHz	44	64	76	87	108	118
<b>Frequency-dependent maximum current @ <math>f_s</math></b> <i>Basic Time Period = 83.3 <math>\mu</math>s (Parameter is22=2)</i>	1.5 kHz	132	175	180	180	180	180
	3 kHz	119	158	180	180	180	180
	6 kHz	89	121	139	155	180	180
	12 kHz	51	73	87	99	120	131
<b>Frequency-dependent maximum current @ <math>f_s</math></b> <i>Basic Time Period = 100 <math>\mu</math>s (Parameter is22=3)</i>	1.25 kHz	132	175	180	180	180	180
	2.5 kHz	125	166	180	180	180	180
	5 kHz	97	131	151	168	180	180
	10 kHz	61	87	101	114	138	150

Table 15: Frequency-dependent maximum current for device size 17

**3.2.4 Power dissipation at rated operation for 230V devices**

Device size		15	16	17
Rated switching frequency	$f_{SN}$ / kHz	4	4	4
Power dissipation at rated operation	<sup>1)</sup> $P_D$ / W	397	533	667

Table 16: Power dissipation of the 230 V devices

<sup>1)</sup> Rated operation corresponds to  $U_N = 230\text{ V}$ ;  $f_{SN}$ ;  $I_N$ ;  $f_N = 50\text{ Hz}$  (typically value)

**3.2.5 Fusing of the 230V devices**

Device size	Max. size of the fuse / A				
	$U_N = 230\text{ V}$ gG (IEC)	$U_N = 240\text{ V}$ class "J"	$U_N = 240\text{ V}$ <sup>1)</sup>		
	SCCR 30 kA	SCCR 5 kA	SCCR 30 kA	Type	Rating
15	80	80	80	SIBA 20 1xy 20.80	700Vac
			80	COOPER BUSSMANN 170M1xy6	700Vac
			80	LITTELFUSE L25S080	250Vac
16	80	90	100	SIBA 20 1xy 20.100	700Vac
			100	COOPER BUSSMANN 170M1xy7	700Vac
			90	LITTELFUSE L25S090	250Vac
17	100	110	125	SIBA 20 1xy 20.125	700Vac
			125	COOPER BUSSMANN 170M1xy8	700Vac
			125	LITTELFUSE L25S125	250Vac

Table 17: Fusing of the 230 V / 240 V devices

<sup>1)</sup> "x" stands for various indicators. "y" stands for different connection variants.



**Short-circuit capacity**

According to the requirements of EN 61439-1 and EN 61800-5-1, the following applies to connection to a power supply: The devices are suitable for use in a circuit capable of delivering not more than 30 kA eff. unaffected symmetrical short-circuit current.

### 3.3 Device data of the 400 V devices

#### 3.3.1 Overview of the 400V devices

The technical data are for 2/4-pole standard motors. With other pole numbers the drive controller must be dimensioned onto the rated motor current. Contact KEB for special or medium frequency motors.

Device size		17	18	19	20
<b>Housing</b>		<b>3</b>			
Rated apparent output power	$S_{out}$ / kVA	29	35	42	52
Max. rated motor power	<sup>1)</sup> $P_{mot}$ / kW	18,5	22	30	37
Rated input voltage	$U_N$ / V	400 (UL: 480)			
Input voltage range	$U_{in}$ / V	280...550			
Mains phases		3			
Mains frequency	$f_N$ / Hz	50 / 60 ±2			
Rated input current @ $U_N = 400V$	$I_{in}$ / A	54	59	66	82
Rated input current @ $U_N = 480V$	$I_{in\_UL}$ / A	44	48	57	71
Insulation resistance @ $U_{dc} = 500V$	$R_{iso}$ / MΩ	> 20			
Output voltage	$U_{out}$ / V	0... $U_{in}$			
Output frequency	<sup>2)</sup> $f_{out}$ / Hz	0...599			
Output phases		3			
Rated output current @ $U_N = 400V$	$I_N$ / A	42	50	60	75
Rated output current @ $U_N = 480V$	$I_{N\_UL}$ / A	34	40	52	65
Rated output overload (60s)	<sup>3)4)</sup> $I_{60s}$ / %	150			
Software current limit	<sup>3)</sup> $I_{lim}$ / %	150			
Overcurrent	<sup>3)</sup> $I_{OC}$ / %	180			
Rated switching frequency	$f_{SN}$ / kHz	2	2	2	4
Max. switching frequency	<sup>5)</sup> $f_{S\_max}$ / kHz	16			
Power dissipation at rated operation	<sup>1)</sup> $P_D$ / W	375	440	525	660
Overload current over time	<sup>3)</sup> $I_{OL}$ / %	<i>„3.2.3.1 Overload characteristic (OL) for 230 V devices“</i>			
Maximum current 0Hz/50Hz at $f_s = 2$ kHz	$I_{out\_max}$ / %	143 / 180	120 / 180	100 / 180	134 / 180
Maximum current 0Hz/50Hz at $f_s = 4$ kHz	$I_{out\_max}$ / %	93 / 180	78 / 180	65 / 180	100 / 180
Maximum current 0Hz/50Hz at $f_s = 8$ kHz	$I_{out\_max}$ / %	36 / 153	30 / 128	25 / 107	50 / 142
Maximum current 0Hz/50Hz at $f_s = 16$ kHz	$I_{out\_max}$ / %	15 / 67	12 / 56	10 / 47	17 / 72
<i>continued on the next page</i>					

Device size	17	18	19	20
<b>Housing</b>	<b>3</b>			
Max. braking current	$I_{B\_max} / A$		76	
Min. braking resistor value	$R_{B\_min} / \Omega$		11	
Braking transistor	6)			
Protective function for braking transistor	Max. cycle time: 120s; Max c.d.f.: 50%			
Protection function braking transistor (Error GTR7 always on)	7)		Short-circuit monitoring	
	Feedback signal evaluation and current switch-off (only for AC mains connection)			
Max. motor cable length shielded	8) // m		100	
<i>Table 18: Overview of the 400 V device data</i>				

- 1) Rated operation corresponds  $U_N = 230 V$ , rated switching frequency, output frequency = 50 Hz (4-pole stand-ard asynchronous motor).
- 2) The output frequency is to be limited in such a way that it does not exceed 1/10 of the switching frequency. Notice! Devices with a maximum output frequency higher than 599Hz are subject to export restrictions.
- 3) The values refer in % to the rated output current  $I_N$ .
- 4) Observe limitations „3.2.3.1 Overload characteristic (OL) for 230 V devices“.
- 5) A detailed description of the derating „3.4.1.2 Switching frequency and temperature of the 400 V devices“.
- 6) The cyclic duration factor is additionally limited by the used braking resistor.
- 7) The feedback signal evaluation monitors the functionality of the braking transistor. The current is switched off via the internal mains input bridge of the AC supply. There is no current switch-off with DC power supply.
- 8) The maximum cable length depends on various factors. Further information can be found in the correspond-ing filter instructions.

### 3.3.2 Voltage and frequencies for 400V devices

Input voltages and frequencies		
Rated input voltage	$U_N / V$	400
Rated mains voltage (USA)	$U_{N\_UL} / V$	480
Input voltage range	$U_{IN} / V$	280...550
Input phases		3
Mains frequency	$f_N / Hz$	50/60
Mains frequency tolerance	$\pm f_N / Hz$	2
<i>Table 19: Input voltages and frequencies of the 400V devices</i>		

DC link voltage		
DC link rated voltage @ $U_N = 400V$	$U_{N\_dc} / V$	565
DC link rated voltage @ $U_{N\_UL} = 480V$	$U_{N\_UL\_dc} / V$	680
DC link voltage working voltage range	$U_{IN\_dc} / V$	390...780
<i>Table 20: DC link voltage for 400V devices</i>		

Output voltages and frequencies		
Output voltage at AC supply	<sup>1)</sup> $U_{out} / V$	0... $U_{N\_ac}$
Output frequency	<sup>2)</sup> $f_{out} / Hz$	0...599
Output phase		3

Table 21: Output voltages and frequencies of the 400V devices

- <sup>1)</sup> The voltage to the motor is dependent on the actual input voltage and the control method => („3.3.2.1 Example of the calculation of the possible motor voltage:“).
- <sup>2)</sup> The output frequency is to be limited in such a way that it does not exceed 1/10 of the switching frequency. Devices with a maximum output frequency higher than 599Hz are restricted for export.

3.3.2.1 Example of the calculation of the possible motor voltage:

The motor voltage for dimensioning of the drive is depending on the used components. The motor voltage reduces according to the following table:

Component	Reduction / %	Example
Mains choke $U_k$	4	Open-loop drive controller with mains- and motor choke at non-rigid supply system: 400 V mains voltage (100%) - 36 V reduced voltage (11%) = 356 V motor voltage
Drive controller open-loop	4	
Drive controller closed-loop	8	
Motor choke $U_k$	1	
Non-rigid supply system	2	

Table 22: Example of the calculation of the possible motor voltage:

3.3.3 Input and output currents / overload for 400 V devices

Device size		17	18	19	20
Rated input current @ $U_N = 400V$	<sup>1)</sup> $I_{in} / A$	55	59	66	82
Rated input current @ $U_{N\_UL} = 480V$	<sup>1)</sup> $I_{in\_UL} / A$	44	48	57	71
Rated input current DC @ $U_{N\_dc} = 565V$	$I_{in\_dc} / A$	66	73	81	101
Rated input current DC @ $U_{N\_UL\_dc} = 680V$	$I_{in\_UL\_dc} / A$	54	58	70	88
Rated output current @ $U_N = 400V$	$I_N / A$	42	50	60	75
Rated output current @ $U_{N\_UL} = 480V$	$I_{N\_UL} / A$	34	40	52	65
Rated output overload (60 s)	<sup>2)</sup> $I_{60s} / \%$	150	150	150	150
Overload current	<sup>2)</sup> $I_{OL} / \%$	=> „3.2.3.1 Overload characteristic (OL) for 230 V devices“			
Software current limit	<sup>2)3)</sup> $I_{lim} / \%$	150	150	150	150
Overcurrent	<sup>2)</sup> $I_{OC} / \%$	180	180	180	180

Table 23: Input and output currents of the 400 V devices

- <sup>1)</sup> The values resulting from rated operation with B6 rectifier circuit and mains choke 4%  $U_k$ .
- <sup>2)</sup> The values refer in % to the rated output current  $I_N$ .
- <sup>3)</sup> Limitation of the current setpoint in closed-loop operation. This setpoint limit is not active in v/f operation.

### 3.3.3.1 Overload characteristic (OL) for 400 V devices

All drive controllers can be operated at rated switching frequency with an utilisation of 150 % for 60s.

The OL overload function is a root mean square (RMS) function.

The greater the difference between the overload and underload phases, the greater the deviation of the RMS from the arithmetic mean value.

For extreme overloads (=> „*Figure 5: Switch-off time  $t$  depending on the overload  $I/I_N$  (OL)*“), the load is weighted more heavily. This means the load is provided with a factor for the calculation of the RMS value, by way that the overload protection function triggers, even if the RMS value does not reach 100%.

#### **Restrictions:**

- The thermal design of the heat sink is based on the rated operation. The following values are taken into account: Rated output current, ambient temperature, rated switching frequency, rated voltage.
- At high ambient temperatures and/or high heat sink temperatures (for example, by preceding utilisation nearby 100%) the drive controller can change to overtemperature error before triggering the protective function OL.
- At low output frequencies or switching frequencies higher than the rated switching frequency, the frequency-dependent maximum current can be exceeded before and error OL2 can be triggered  
=> „*3.2.3.1 Overload characteristic (OL) for 230 V devices*“.

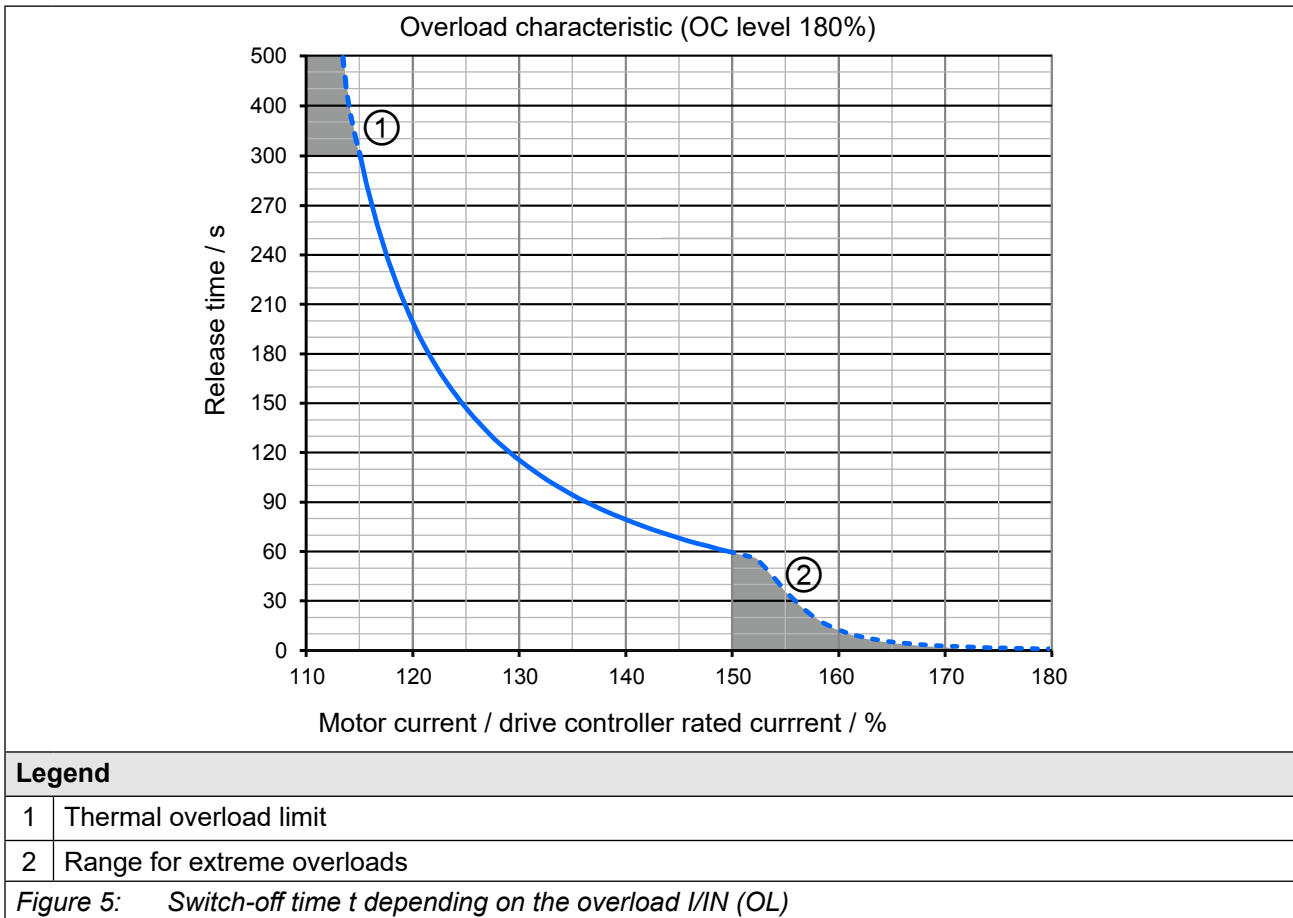

- On exceeding a load of 105 % the overload integrator starts.
- When falling below the integrator counts backwards.
- If the integrator reaches the overload characteristic "Error! overload (OL)" is triggered.

After a cooling down period, the integrator can be reset now. The drive controller must remain switched on during the cooling down phase.

**Operation in the range of the thermal overload limit**

Due to the high steepness of the overload characteristic, the duration of a permissible overload in this range ① cannot be determined exactly. Therefore, the design of the drive controller should be assumed to have a maximum overload time of 300s.

3.3.3.2 Frequency-dependent maximum current (OL2) for 400V devices

The characteristics of the maximum currents for a switching frequency which are depending on the output frequency are different for each drive controller, but the following rules are generally applicable:

- Applies for the rated switching frequency: At 0 Hz output frequency the drive controller can provide at least the rated output current.
- Lower maximum currents apply for switching frequencies > rated switching frequency.

If error (OL2) shall be triggered on exceeding the maximum currents or if the switching frequency is automatically reduced (derating) can be adjusted in the drive controller parameters.

The following characteristic curve indicates the permissible maximum current for the output frequency values 0 Hz, 3 Hz, 6 Hz, 12.5 Hz, 25 Hz and 50 Hz. Device size 19 is represented exemplary (with 2 kHz rated switching frequency).

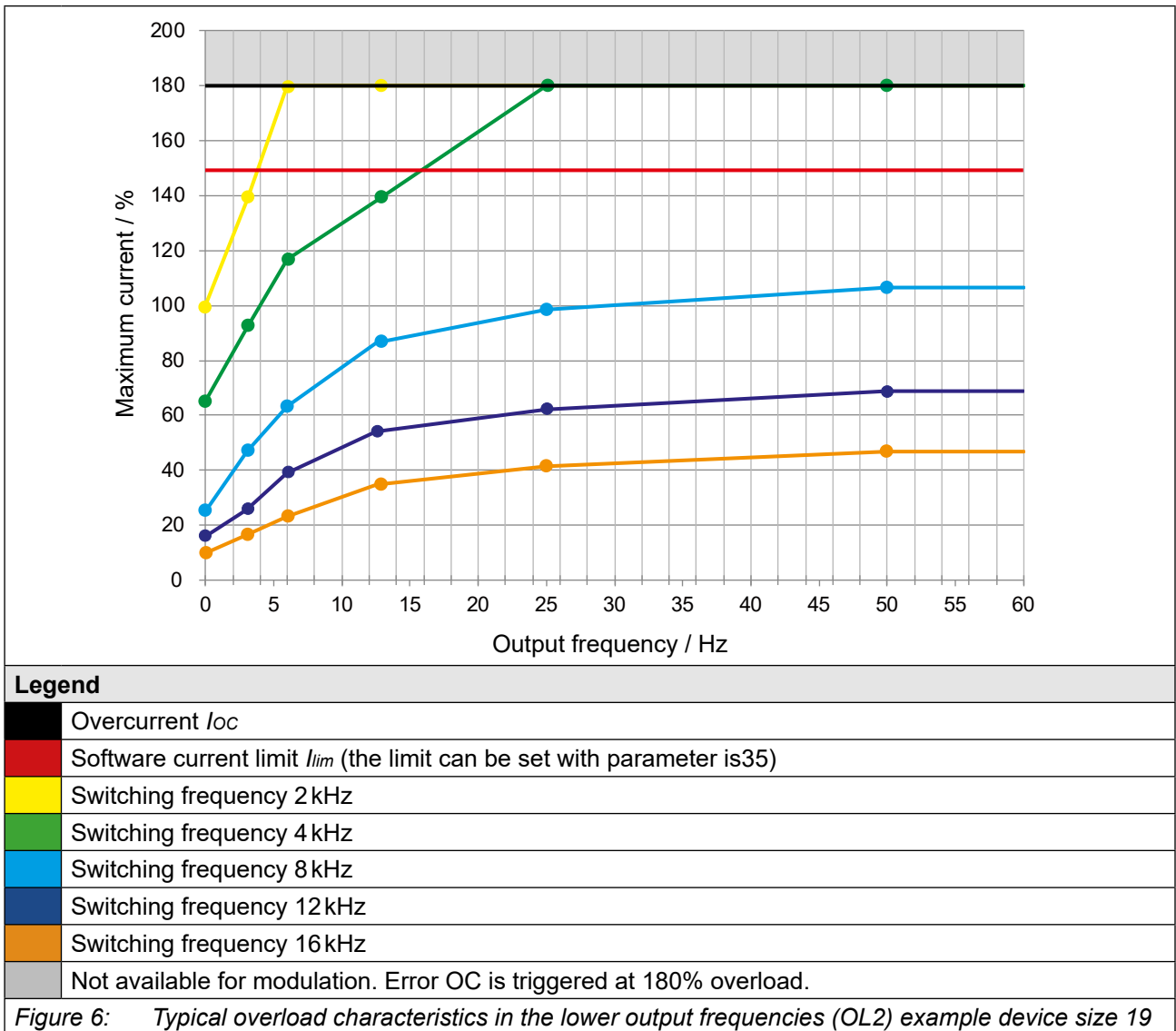

Figure 6: Typical overload characteristics in the lower output frequencies (OL2) example device size 19



The frequency-dependent maximum current  $I_{out\_max}$  / % refers in % to the rated output current  $I_N$ .

The current remains constant from the last specified output frequency value.



The values for the respective device size are listed in the following tables.

**Frequency-dependent maximum current**

Device size	17						
Rated switching frequency	2 kHz						
Output frequency	$f_{out}$ / Hz	0	3	6	12,5	25	50
<b>Frequency-dependent maximum current @ <math>f_s</math></b> $i_{out\_max}$ % <i>Basic Time Period = 62.5 <math>\mu</math>s (Parameter is22=0)</i>	2 kHz	143	180	180	180	180	180
	4 kHz	93	131	167	180	180	180
	8 kHz	36	67	91	124	141	153
	16 kHz	15	24	34	50	60	67
<b>Frequency-dependent maximum current @ <math>f_s</math></b> $i_{out\_max}$ % <i>Basic Time Period = 71.4 <math>\mu</math>s (Parameter is22=1)</i>	1.75 kHz	143	180	180	180	180	180
	3.5 kHz	106	148	180	180	180	180
	7 kHz	50	83	110	147	166	179
	14 kHz	18	30	44	64	74	83
<b>Frequency-dependent maximum current @ <math>f_s</math></b> $i_{out\_max}$ % <i>Basic Time Period = 83.3 <math>\mu</math>s (Parameter is22=2)</i>	1.5 kHz	143	180	180	180	180	180
	3 kHz	118	165	180	180	180	180
	6 kHz	65	99	129	170	180	180
	12 kHz	22	36	55	77	89	98
<b>Frequency-dependent maximum current @ <math>f_s</math></b> $i_{out\_max}$ % <i>Basic Time Period = 100 <math>\mu</math>s (Parameter is22=3)</i>	1.25 kHz	143	180	180	180	180	180
	2.5 kHz	131	180	180	180	180	180
	5 kHz	79	115	148	180	180	180
	10 kHz	29	52	73	100	115	125

Table 24: Frequency-dependent maximum current for device size 17

Device size		18					
Rated switching frequency		2 kHz					
Output frequency	$f_{out}$ / Hz	0	3	6	12,5	25	50
<b>Frequency-dependent maximum current @ <math>f_s</math></b> <i>Basic Time Period = 62.5 <math>\mu</math>s (Parameter is22=0)</i>	2 kHz	120	166	180	180	180	180
	4 kHz	78	110	140	180	180	180
	8 kHz	30	56	76	104	118	128
	16 kHz	12	20	28	42	50	56
<b>Frequency-dependent maximum current @ <math>f_s</math></b> <i>Basic Time Period = 71.4 <math>\mu</math>s (Parameter is22=1)</i>	1.75 kHz	120	166	180	180	180	180
	3.5 kHz	89	124	159	180	180	180
	7 kHz	42	70	92	123	139	150
	14 kHz	15	25	37	53	62	69
<b>Frequency-dependent maximum current @ <math>f_s</math></b> <i>Basic Time Period = 83.3 <math>\mu</math>s (Parameter is22=2)</i>	1.5 kHz	120	166	180	180	180	180
	3 kHz	99	138	178	180	180	180
	6 kHz	54	83	108	142	160	172
	12 kHz	18	30	46	64	74	82
<b>Frequency-dependent maximum current @ <math>f_s</math></b> <i>Basic Time Period = 100 <math>\mu</math>s (Parameter is22=3)</i>	1.25 kHz	120	166	180	180	180	180
	2.5 kHz	110	152	180	180	180	180
	5 kHz	66	97	124	161	180	180
	10 kHz	24	43	61	84	96	105

Table 25: Frequency-dependent maximum current for device size 18

Device size		19					
Rated switching frequency		2 kHz					
Output frequency	$f_{out}$ / Hz	0	3	6	12,5	25	50
<b>Frequency-dependent maximum current @ <math>f_s</math></b> <i>Basic Time Period = 62.5 <math>\mu</math>s (Parameter is22=0)</i>	2 kHz	100	139	180	180	180	180
	4 kHz	65	92	117	150	169	180
	8 kHz	25	47	64	87	99	107
	16 kHz	10	17	24	35	42	47
<b>Frequency-dependent maximum current @ <math>f_s</math></b> <i>Basic Time Period = 71.4 <math>\mu</math>s (Parameter is22=1)</i>	1.75 kHz	100	139	180	180	180	180
	3.5 kHz	74	104	133	165	180	180
	7 kHz	35	58	77	103	116	125
	14 kHz	13	21	31	45	52	58
<b>Frequency-dependent maximum current @ <math>f_s</math></b> <i>Basic Time Period = 83.3 <math>\mu</math>s (Parameter is22=2)</i>	1.5 kHz	100	139	180	180	180	180
	3 kHz	83	115	149	180	180	180
	6 kHz	45	70	90	119	134	144
	12 kHz	15	25	39	54	62	69
<b>Frequency-dependent maximum current @ <math>f_s</math></b> <i>Basic Time Period = 100 <math>\mu</math>s (Parameter is22=3)</i>	1.25 kHz	100	139	180	180	180	180
	2.5 kHz	92	127	165	180	180	180
	5 kHz	55	81	104	135	151	162
	10 kHz	20	36	51	70	80	88

Table 26: Frequency-dependent maximum current for device size 19 (2 kHz)

Device size		19					
Rated switching frequency		4 kHz					
Output frequency	$f_{out}$ / Hz	0	3	6	12,5	25	50
<b>Frequency-dependent maximum current @ <math>f_s</math></b> <i>Basic Time Period = 62.5 <math>\mu</math>s (Parameter is22=0)</i>	2 kHz	134	180	180	180	180	180
	4 kHz	100	140	180	180	180	180
	8 kHz	50	75	100	117	134	142
	16 kHz	17	32	47	59	65	72
<b>Frequency-dependent maximum current @ <math>f_s</math></b> <i>Basic Time Period = 71.4 <math>\mu</math>s (Parameter is22=1)</i>	1.75 kHz	134	180	180	180	180	180
	3.5 kHz	109	152	180	180	180	180
	7 kHz	63	92	120	138	155	163
	14 kHz	23	40	57	70	79	86
<b>Frequency-dependent maximum current @ <math>f_s</math></b> <i>Basic Time Period = 83.3 <math>\mu</math>s (Parameter is22=2)</i>	1.5 kHz	134	180	180	180	180	180
	3 kHz	117	164	180	180	180	180
	6 kHz	75	108	140	159	175	180
	12 kHz	29	47	67	80	92	100
<b>Frequency-dependent maximum current @ <math>f_s</math></b> <i>Basic Time Period = 100 <math>\mu</math>s (Parameter is22=3)</i>	1.25 kHz	134	180	180	180	180	180
	2.5 kHz	125	175	180	180	180	180
	5 kHz	88	124	160	180	180	180
	10 kHz	40	61	84	99	113	121

Table 27: Frequency-dependent maximum current for device size 19 (4 kHz)

Device size		20					
Rated switching frequency		2 kHz					
Output frequency	$f_{out}$ / Hz	0	3	6	12,5	25	50
<b>Frequency-dependent maximum current @ <math>f_s</math></b> <i>Basic Time Period = 62.5 <math>\mu</math>s (Parameter is22=0)</i>	2 kHz	107	150	180	180	180	180
	4 kHz	80	112	144	160	174	180
	8 kHz	40	60	80	94	107	114
	16 kHz	14	26	38	47	52	58
<b>Frequency-dependent maximum current @ <math>f_s</math></b> <i>Basic Time Period = 71.4 <math>\mu</math>s (Parameter is22=1)</i>	1.75 kHz	107	150	180	180	180	180
	3.5 kHz	87	122	155	174	180	180
	7 kHz	50	73	96	110	124	130
	14 kHz	18	32	46	56	63	69
<b>Frequency-dependent maximum current @ <math>f_s</math></b> <i>Basic Time Period = 83.3 <math>\mu</math>s (Parameter is22=2)</i>	1.5 kHz	107	150	180	180	180	180
	3 kHz	94	131	166	180	180	180
	6 kHz	60	86	112	127	140	147
	12 kHz	23	38	54	64	74	80
<b>Frequency-dependent maximum current @ <math>f_s</math></b> <i>Basic Time Period = 100 <math>\mu</math>s (Parameter is22=3)</i>	1.25 kHz	107	150	180	180	180	180
	2.5 kHz	100	140	176	180	180	180
	5 kHz	70	99	128	144	157	164
	10 kHz	32	49	67	79	90	97

Table 28: Frequency-dependent maximum current for device size 20

3.3.4 Overview of rectifier data

Device size		17	18	19	20
Rectifier rated power	$P_{rect}$ / kW	21	25	34	41
Rectifier continuous power	<sup>1)</sup> $P_{rect\_cont}$ / kW	41	41	41	41
Continuous input current @ $U_N = 400V$	<sup>1)</sup> $i_{in\_cont}$ / A	82	82	82	82
Continuous input current @ $U_{N\_UL} = 480V$	<sup>1)</sup> $i_{in\_UL\_cont}$ / A	71	71	71	71
Rated output current DC @ $U_{N\_dc} = 565V$	$i_{out\_dc}$ / A	66	73	81	101
Continuous output current DC @ $U_{N\_dc} = 565V$	<sup>1)</sup> $i_{out\_dc\_cont}$ / A	101	101	101	101
Rated output current DC @ $U_{N\_UL\_dc} = 680V$	$i_{out\_UL\_dc}$ / A	54	58	70	88
Continuous output current DC @ $U_{N\_UL\_dc} = 680V$	<sup>1)</sup> $i_{out\_UL\_dc\_cont}$ / A	88	88	88	88

Table 29: Overview of rectifier data

<sup>1)</sup> Continuous operation is a load that exceeds the rated operation. Continuous operation only occurs if the internal rectifier is used to supply additional drive controllers via the DC terminals => „5.3.6 DC-bus connection“. In continuous operation, the OH error can be triggered depending on the operating conditions of the internal inverter.

### 3.3.5 Power dissipation at rated operation for 400V devices

Device size		17	18	19	20	
Rated switching frequency	$f_{SN}$ / kHz	2	2	2	4	2
Power dissipation at rated operation	<sup>1)</sup> $P_D$ / W	375	440	525	660	670
Power dissipation at rated operation DC	<sup>2)</sup> $P_{D\_dc}$ / W	300	355	425	565	520

Table 30: Power dissipation of the 400 V devices

<sup>1)</sup> Rated operation corresponds to  $U_N = 400$  V;  $f_{SN}$ ;  $I_N$ ;  $f_N = 50$  Hz (typically value)

<sup>2)</sup> Rated operation DC corresponds to  $U_{N\_dc} = 565$  V; (typical value)

### 3.3.6 Fusing of the 400V devices

#### 3.3.6.1 Fuse protection for AC supply

Device size	Max. size of the fuse / A			
	$U_N = 400$ V gG (IEC)	$U_N = 480$ V class "J"	$U_N = 480$ V <sup>1)</sup>	
	SCCR 30 kA	SCCR 5 kA	SCCR 30 kA	Type
17	63	45	50	SIBA 20 1xy 20.50
			50	COOPER BUSSMANN 170M1xy4
			50	LITTELFUSE L70QS050
18	80	60	50	SIBA 20 1xy 20.50
			50	COOPER BUSSMANN 170M1xy4
			50	LITTELFUSE L70QS050
19	80	70	80	SIBA 10 1xy 20.80
			80	COOPER BUSSMANN 170M1xy6
			70	LITTELFUSE L70QS070
20	100	90	100	SIBA 21 1xy 20.100
			100	COOPER BUSSMANN 170M1xy7
			90	LITTELFUSE L70QS090

Table 31: Fusing of the 400 V / 480 V devices

<sup>1)</sup> "x" stands for various indicators. "y" stands for different connection variants.



#### Short-circuit capacity

According to the requirements of EN 61439-1 and EN 61800-5-1, the following applies to connection to a power supply: The devices are suitable for use in a circuit capable of delivering not more than 30 kA eff. unaffected symmetrical short-circuit current.

3.3.6.2 Protection of 400 V devices with DC power supply

Device size	Recommended size of the fuse / A		Permissible fuses <sup>1)</sup>
	$U_{N\_dc} = 565V$	$U_{N\_dc} = 680V$	
	SCCR 50 kA	SCCR 50 kA	
17	90	80	SIBA 50 250 06.80 SIBA 20 209 37.100 <sup>2)</sup> SIBA 50 280 06.100 SIBA 50 268 06.125 SIBA 20 031 34.125 Bussmann FWP-100A22F Bussmann 170M1420 Littelfuse L70QS200
18	100	90	
19	125	100	
20	150	125	

Table 32: DC-Fusing of the 400 V / 480 V devices

<sup>1)</sup> Fuses of the same type with lower rated currents can be used if they are suitable for the application.

<sup>2)</sup> Fuse without UL certification

**NOTICE**

**Observe the rated voltage of the fuse!**

- ▶ The rated voltage of the fuse must be at least equal to the maximum DC supply voltage of the drive controller.

3.3.6.3 Motor protection switch / circuit breaker

This chapter lists the recommended and alternative motor protection switches/circuit breakers for protecting the drive controller. The selection of the recommended protection switches is based on continuous operation (S1 operation) at 100% load and maximum ambient temperature. If operating conditions differ, the circuit breakers must be dimensioned accordingly (see manufacturer's documentation for the respective circuit breakers).

Device size	Motor protection switch / circuit breaker						
	IEC ( $U_N = 400V$ )			UL ( $U_{N\_UL} = 480V$ )			
	Type	Rated current / A	SCCR @ $U_N$ / kA	Type	Rated current / A	Rated power / hp	SCCR @ $U_{N\_UL}$ / kA
17	Eaton PKZM4-58	58	30	Eaton PKZM4-50	50	30	30
18	Eaton PKZM4-63	65	30	Eaton PKZM4-50	50	30	30
19	Siemens 3RV2032-4KA10	73	30	Eaton PKZM4-58	58	40	30
20	Siemens 3RV2042-4RA10	84	30	Siemens 3RV2032-4KA10	73	60	30

Table 33: Recommended motor protection switches/circuit breakers for 400 V/480 V devices

As an alternative to the recommended motor protection switches/circuit breakers, all circuit breakers listed in the following table may be used. Circuit breakers of the same type with a lower rated current or other features (e.g., connection terminals, actuation types, etc.) may also be used, provided that they are suitable for the application and the differing features do not have a negative effect on the pass values ( $I^2t$  and  $I_p$ ). Circuit breakers of the same type with lower breaking capacity may be used provided they are suitable for the application. In this case, the short-circuit current rating (SCCR) of the combination of drive controller and circuit breaker is reduced to the breaking capacity of the circuit breaker.

Some motor circuit breakers require additional accessories in order to be used as Type E Combination Motor Controllers in UL-certified installations (see manufacturer's documentation for the respective circuit breaker).

Recommended motor protection switches / circuit breakers			
Type	Rated current / A	Rated power / hp	SCCR @ $U_N$ / kA
Eaton PKZM4-63	65	40	30
Siemens 3RV2032-4KA10	73	60	30
Siemens 3RV2042-4YA10	93	75	30
Schneider GV3P65	65	40	30
Siemens 3VA5110-6ED31-0AA0	100	-	30
Schneider B JL36100	100	-	30

Table 34: Recommended motor protection switches/circuit breakers for 400 V/480 V devices



**IEC only:**

Motor protection switches/circuit breakers not listed here may be used provided they meet the following requirements:

- Passage integral  $I^2t @ U_N < 470 \text{ kA}^2\text{s}$
- Passing current  $I_p @ U_N < 17\text{kA}$

### 3.4 General electrical data

#### 3.4.1 Switching frequency and temperature

The drive controller cooling is designed by way that the heat sink overtemperature threshold is not exceeded at rated conditions. A switching frequency higher than the rated switching frequency also produces higher losses and thus a higher heat sink heating. If the heat sink temperature reaches a critical threshold ( $T_{DR}$ ), the switching frequency can be reduced automatically step by step. This prevents that the drive controller switches off due to overheating of the heat sink. If the heat sink temperature falls below the threshold  $T_{UR}$ , the switching frequency is increased back to the setpoint. At temperature  $T_{EM}$  the switching frequency is immediately reduced to rated switching frequency. „Derating“ must be activated, for this function to work.

##### 3.4.1.1 Switching frequency and temperature of the 230 V devices

Device size		15	16	17
Rated switching frequency	<sup>1)</sup> $f_{SN}$ / kHz	4	4	4
Max. switching frequency	<sup>1)</sup> $f_{S\_max}$ / kHz	16		
Min. switching frequency	<sup>1)</sup> $f_{S\_min}$ / kHz	2		
Max. heat sink temperature	$T_{HS}$ / °C	85		
Temperature for derating the switching frequency	$T_{DR}$ / °C	75		
Temperature for uprating the switching frequency	$T_{UR}$ / °C	65		
Temperature for switching to rated switching frequency	$T_{EM}$ / °C	80		

Table 35: Switching frequency and temperature of the 230 V devices

<sup>1)</sup> The output frequency is to be limited in such a way that it does not exceed 1/10 of the switching frequency.

##### 3.4.1.2 Switching frequency and temperature of the 400 V devices

Device size		17	18	19	20
Rated switching frequency	<sup>1)</sup> $f_{SN}$ / kHz	2	2	2	4
Max. switching frequency	<sup>1)</sup> $f_{S\_max}$ / kHz	16			
Min. switching frequency	<sup>1)</sup> $f_{S\_min}$ / kHz	2			
Max. heat sink temperature	$T_{HS}$ / °C	85			
Temperature for derating the switching frequency	$T_{DR}$ / °C	75			
Temperature for uprating the switching frequency	$T_{UR}$ / °C	65			
Temperature for switching to rated switching frequency	$T_{EM}$ / °C	80			

Table 36: Switching frequency and temperature of the 400 V devices

<sup>1)</sup> The output frequency is to be limited in such a way that it does not exceed 1/10 of the switching frequency.

### 3.4.2 DC link / braking transistor function



#### Activation of the braking transistor function

To be able to use the braking transistor, the function must be activated with parameter "is30 braking transistor function".

For more information => [F6 Programming manual](#).

#### NOTICE

#### Falling below the minimum braking resistor value!

#### Destruction of the drive controller

- ▶ The minimum brake resistance value must not fall below!

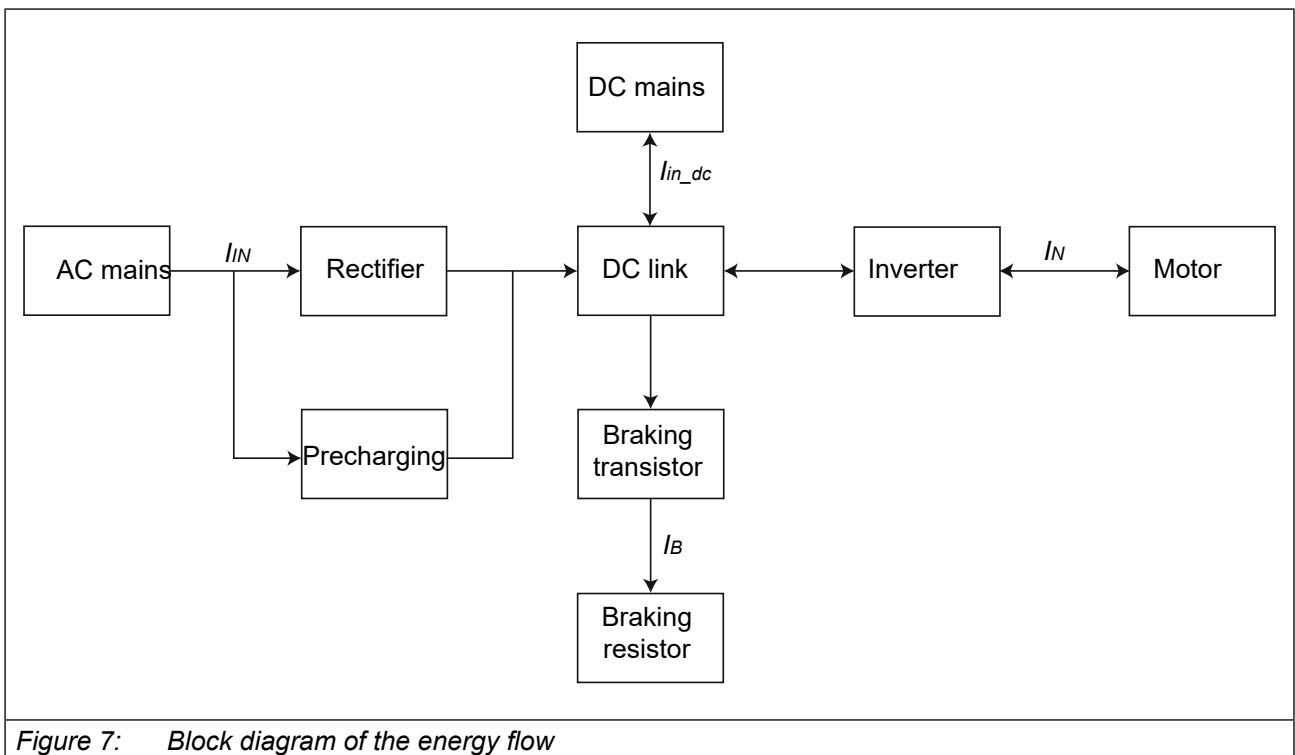

Figure 7: Block diagram of the energy flow

#### NOTICE

#### Destruction of the drive controller!

If the error "ERROR GTR7 always ON" occurs, the current consumption is switched off internally via the mains input bridge of the AC supply.

- ▶ If the error "ERROR GTR7 always ON" occurs, the drive controller is defective and must be disconnected from the power supply no later than 16 hours!
- ▶ With DC mains connection and the use of non-intrinsically safe braking resistors or sub-mounted braking resistors, the drive controller must be de-energised after 1 second at the latest.

3.4.2.1 DC link / braking transistor function of the 230V devices

Device size		15	16	17
Rated DC link voltage @ $U_N = 230V$	$U_{N\_dc} / V$	325		
Rated DC link voltage @ $U_{N\_UL} = 240V$	$U_{N\_dc\_UL} / V$	339		
DC link voltage working voltage range	$U_{in\_dc} / V$	240...373		
DC switch-off level "ERROR underpotential"	$U_{UP} / V$	216		
DC switch-off level "ERROR overpotential"	$U_{OP} / V$	400		
DC switch-off level braking resistor	<sup>1)</sup> $U_B / V$	380		
Max. braking current	$I_{B\_max} / A$	76		
Min. braking resistor value	$R_{B\_min} / \Omega$	6		
Braking transistor	<sup>2)</sup>	Max. cycle time: 120 s; Max c.d.f.: 50%		
Protective function for braking transistor		Short-circuit monitoring		
Protection function braking transistor (Error GTR7 always on)	<sup>3)</sup>	Feedback signal evaluation and current shutdown		
DC link capacity	$C_{int} / \mu F$	5040	6160	7280
<i>Table 37: DC link / braking transistor function of the 230 V devices</i>				

- <sup>1)</sup> The DC switching level for the braking transistor is adjustable. The default value is the value specified in the table.
- <sup>2)</sup> The cyclic duration factor is additionally limited by the used braking resistor.
- <sup>3)</sup> The feedback signal evaluation monitors the functionality of the braking transistor. The current is switched off via the internal mains input bridge of the AC supply.

## 3.4.2.2 DC link / braking transistor function of the 400 V devices

Device size		17	18	19	20
Rated DC link voltage @ $U_N = 400V$	$U_{N\_dc} / V$	565			
Rated DC link voltage @ $U_{N\_UL} = 480V$	$U_{N\_dc\_UL} / V$	680			
DC link voltage working voltage range	$U_{in\_dc} / V$	390...780			
DC switch-off level "ERROR underpotential"	$U_{UP} / V$	240			
DC switch-off level "ERROR overpotential"	$U_{OP} / V$	840			
DC switch-off level braking resistor	<sup>1)</sup> $U_B / V$	780			
Max. braking current	$I_{B\_max} / A$	76			
Min. braking resistor value	$R_{B\_min} / \Omega$	11			
Braking transistor	<sup>2)</sup>	Max. cycle time: 120 s; Max c.d.f.: 50 %			
Protective function for braking transistor		Short-circuit monitoring			
Protection function braking transistor (Error GTR7 always on)	<sup>3)</sup>	Feedback signal evaluation and current switch-off (only for AC connection)			
DC link capacity	$C_{int} / \mu F$	1400	1680	2240	2800
Max. prechargeable total capacity @ $U_N = 400 V$	<sup>4)</sup> $C_{pc\_max} / \mu F$	2300	2300	2300	3100
Max. prechargeable total capacity @ $U_{N\_UL} = 480 V$	<sup>4)</sup> $C_{pc\_max\_UL} / \mu F$	2300	2300	2300	3100

Table 38: DC link / braking transistor function of the 400 V devices

- <sup>1)</sup> The DC switching level for the braking transistor is adjustable. The default value is the value specified in the table.
- <sup>2)</sup> The cyclic duration factor is additionally limited by the used braking resistor.
- <sup>3)</sup> The feedback signal evaluation monitors the functionality of the braking transistor. The current is switched off via the internal mains input bridge of the AC supply. There is no current switch-off with DC power supply.
- <sup>4)</sup> If the precharge time is shortened, only the internal DC link capacitance can be precharged => [F6 Programming manual](#).

3.4.3 Fan

Device size		15	16	17	18	19	20
Interior fan	Number	1					
	Speed-variable	no					
Heat sink fan	Number	1					
	Speed-variable	yes					

Table 39: Fan



The fans are speed variable. They are automatically controlled to high or low speed depending on the setting of the temperature limits in the software.

**NOTICE**

**Destruction of the fan!**

Take care that no foreign substances drop into the fan!

### 3.4.3.1 Switching behaviour of the fans

Temperature monitoring controls the fans with various switch-on and switch-off points.

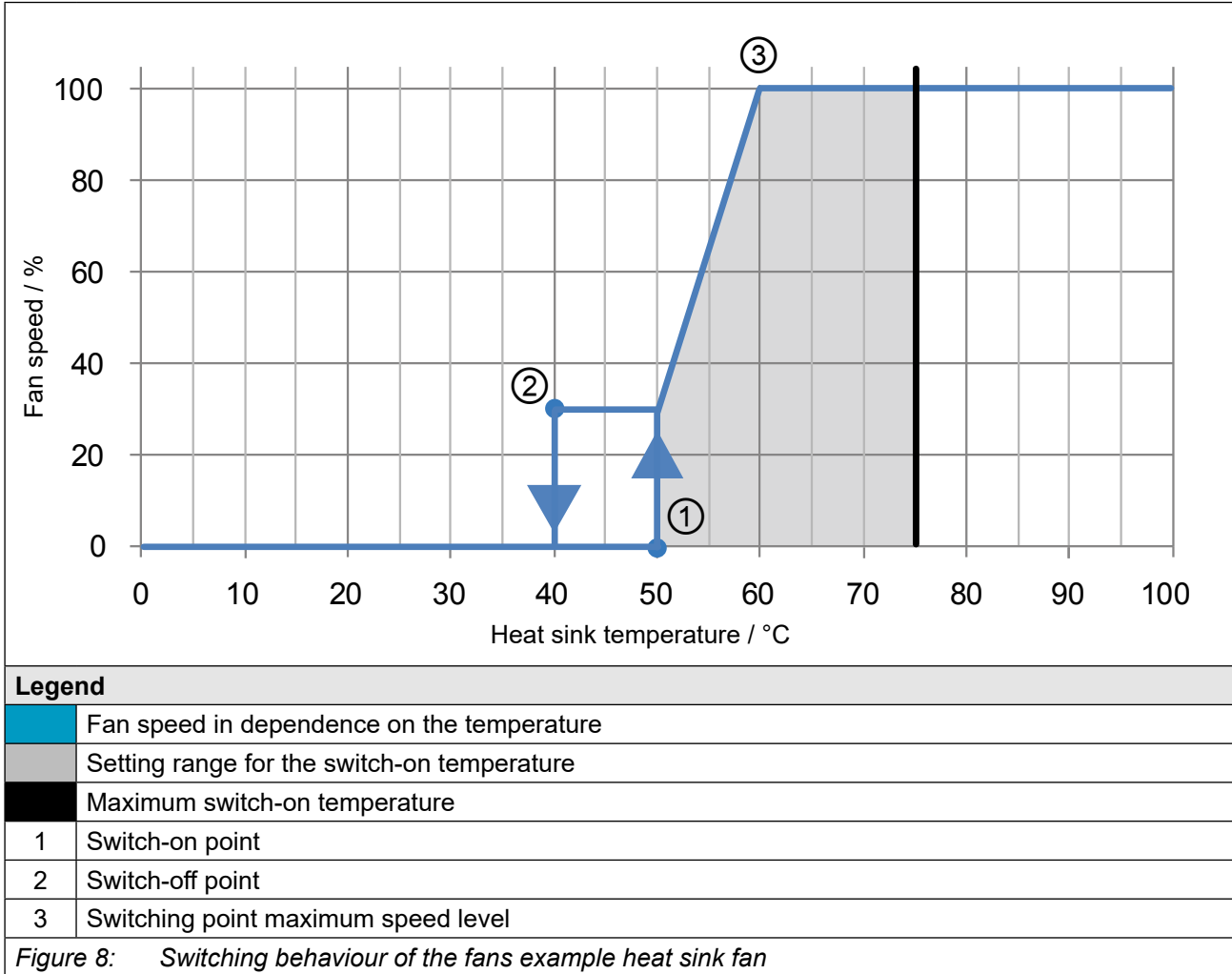

### 3.4.3.2 Switching points of the fans

The switching point for the switch-on temperature and the maximum speed level of the fans are adjustable. The following table shows the default values.

Fan		Heat sink	Interior
Switch-on temperature	$T / ^\circ\text{C}$	50	45
Maximum speed level	$T / ^\circ\text{C}$	60	55

Table 40: Switching points of the fans

## 4 Installation

### 4.1 Dimensions and weights

#### 4.1.1 Built-in version air cooler

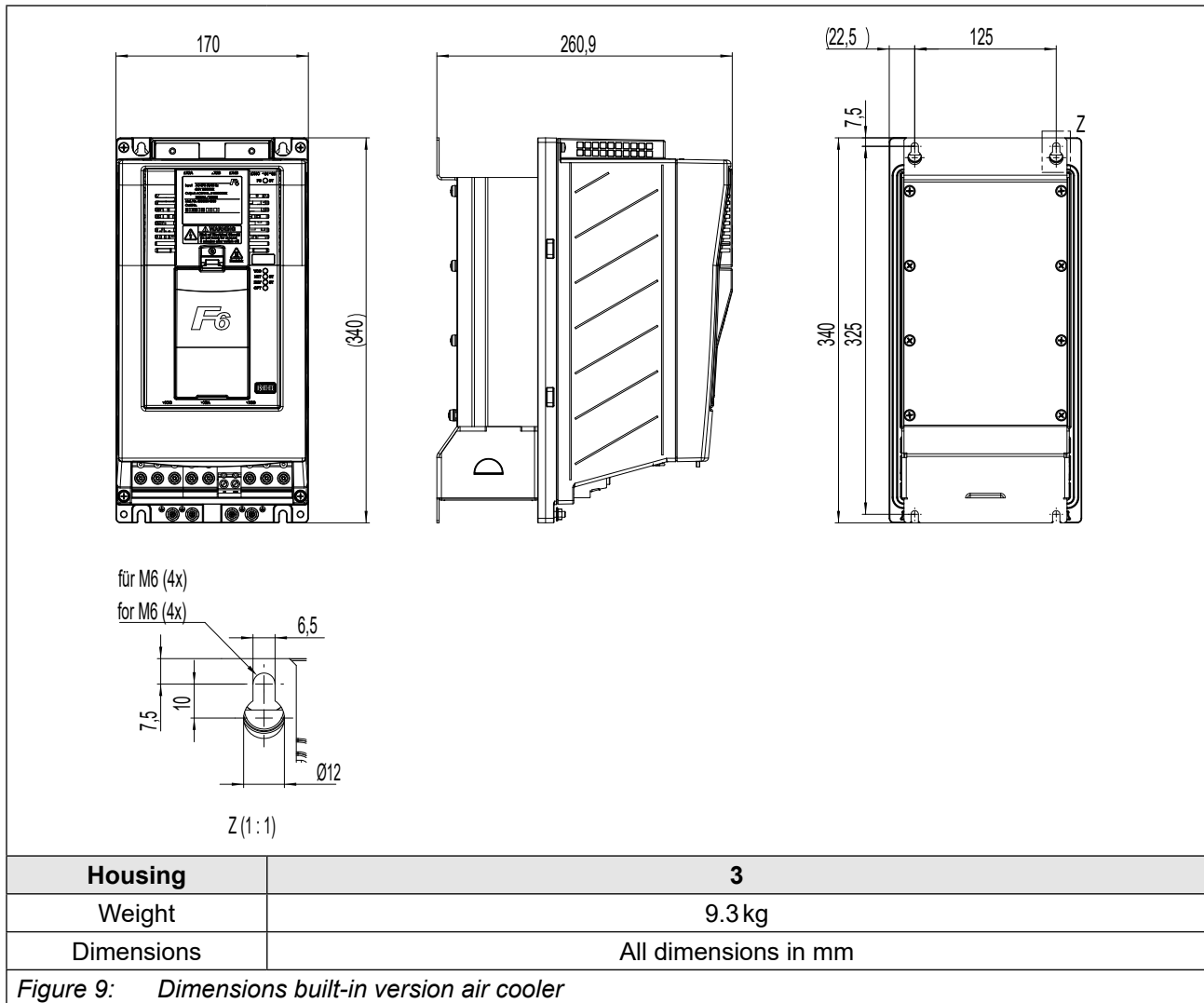

4.1.2 Built-in version fluid cooler (water)

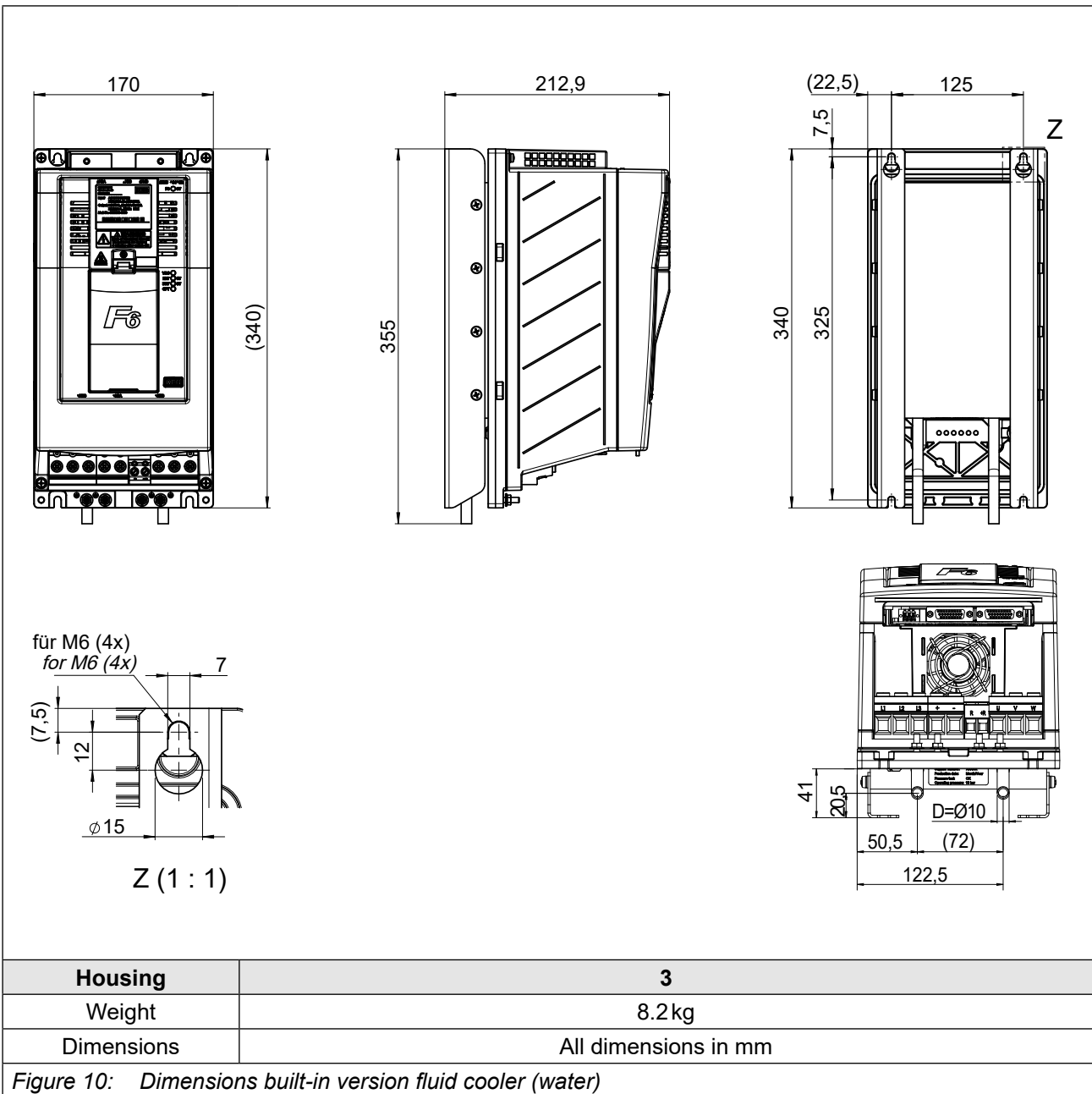

**4.1.3 Push-through version air cooler IP20, IP54-ready**

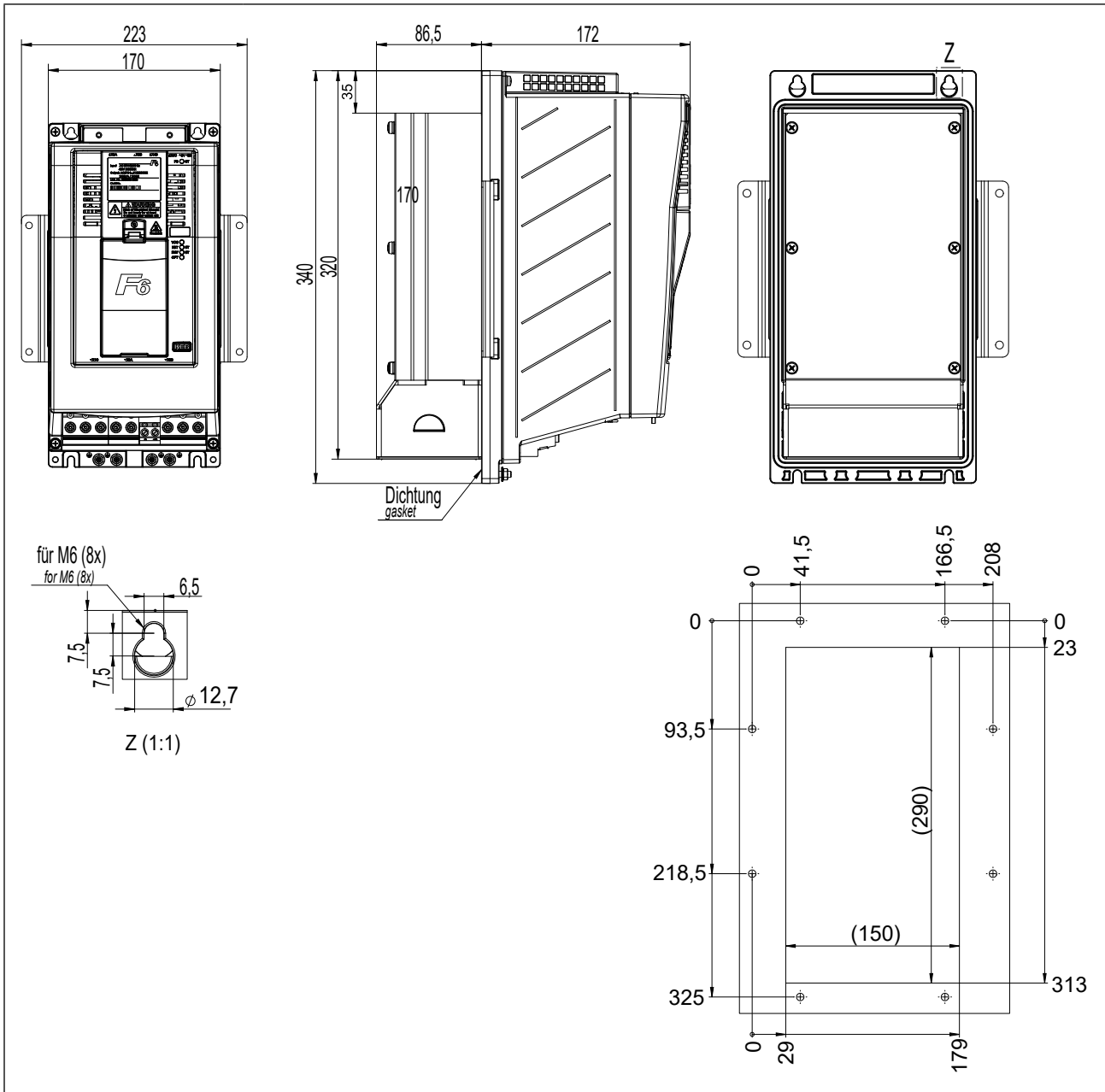

<b>Housing</b>	<b>3</b>
Weight	9.5 kg
Dimensions	All dimensions in mm

Figure 11: Dimensions push-through version air cooler IP20, IP54-ready

4.1.4 Push-through version fluid cooler (water) IP20, IP54-ready

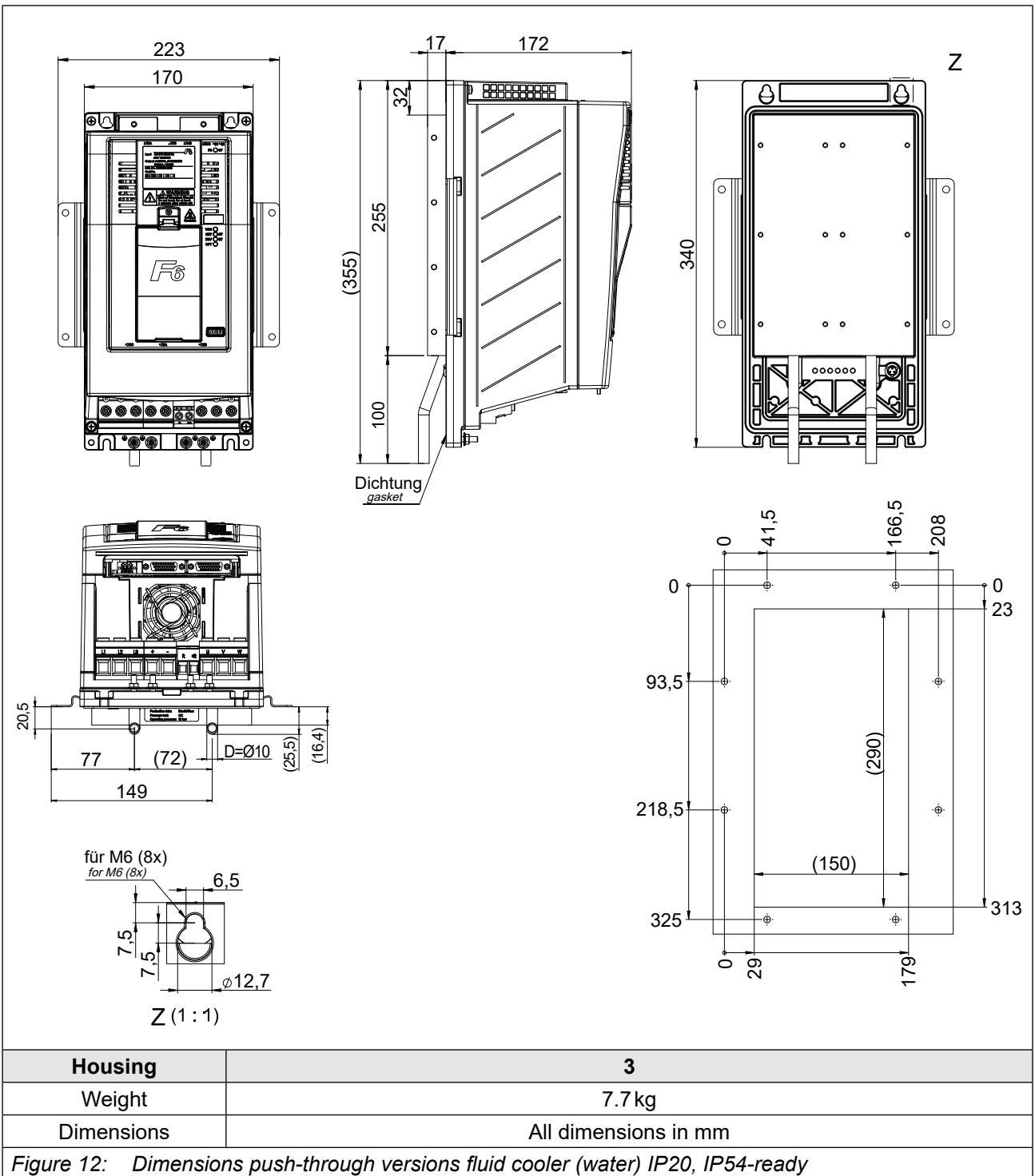

## 4.2 Control cabinet installation

### 4.2.1 Mounting instructions

For the mounting of the drive controllers the following mounting materials with the appropriate quality were tested by KEB.

Required material	Tightening torque
Hexagon-head screw <i>ISO 4017</i> - M6 - 8.8	9Nm 80lb inch
Flat washer <i>ISO 7090</i> - 6 - 200 HV	–
<i>Table 41: Mounting instructions for built-in version</i>	

Required material	Tightening torque
Hexagon-head screw <i>ISO 4017</i> - M6 - 8.8	9Nm 80lb inch
Flat washer <i>ISO 7090</i> - 6 - 200 HV	–
<i>Table 42: Mounting instructions for push-through version</i>	

### NOTICE

#### Use of other fixing material

- The alternatively selected fixing material must meet the above material characteristics (quality) and tightening torques!

The use of other fixing materials is beyond the control of KEB and is therefore the sole responsibility of the customer.

#### 4.2.2 Mounting distances

Power dissipation for control cabinet design „3.3.5 Power dissipation at rated operation for 400V devices“. A lower value can be used here depending on the operating mode/load.



##### Mounting the drive controller

For reliable operation, the drive controller must be mounted without any distance on a smooth, closed, metallicly bright mounting plate.

Mounting distances	Dimension	Distance in mm	Distance in inch
	A	150	6
	B	100	4
	C	30	1,2
	D	0	0
	E	0	0
	F <sup>1)</sup>	50	2
	<sup>1)</sup> Distance to preceding elements in the control cabinet door.		

Figure 13: Mounting distances

4.2.3 Installation of IP54-ready devices

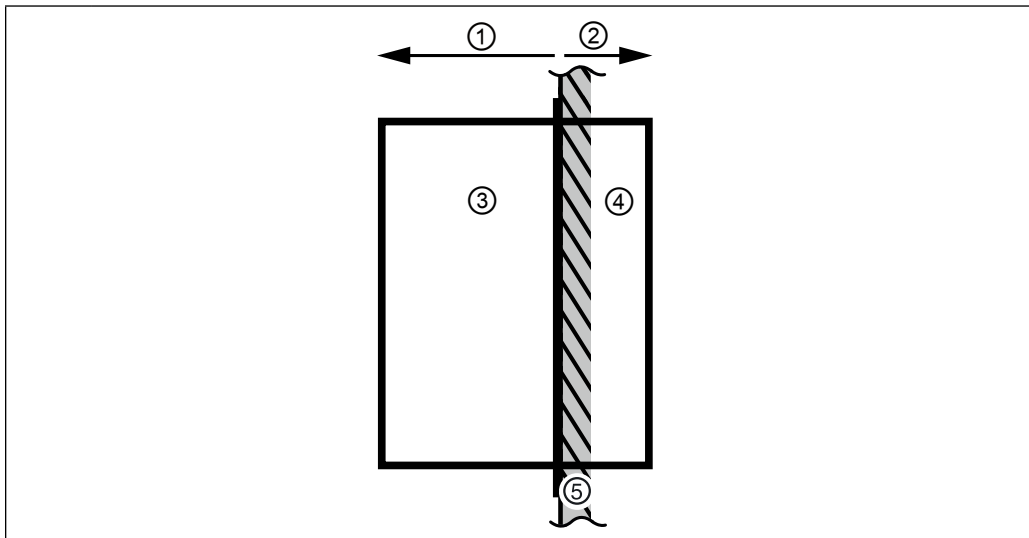

Legend	
1	IP20 zone inside the housing
2	IP54 zone outside the housing
3	Drive controller (power unit and control unit)
4	Drive controller (heat sink)
5	Housing (e.g. Control cabinet wall)

Figure 14: Installation of IP54-ready devices



**IP54 zone: Heat sink outside the housing (Control cabinet)**

The protection class IP54 can only be achieved when the device is properly installed.

For proper installation, a suitable IP54 seal (=> „5.4.2 Seal for IP54-ready devices“) must be installed between heat sink and housing (e.g. control cabinet wall).

The tightness must be checked after the installation. If properly installed, the separation to the housing corresponds to degree of protection IP54.

In the case of fan-cooled units, the fans must be protected from negative environmental influences.

These include combustible, oily or dangerous fumes or gases, corrosive chemicals, coarse foreign bodies and excessive dust. This applies especially to the access of the heatsink from the top (air outlet).Icing is inadmissible.

UL: Device heat sink is classified as NEMA type 1

**IP20 zone: Device inside the housing**

This part is intended for the installation in a suitable housing for the required degree of protection (e.g. control cabinet).

The power connections are excluded => „3.1.1 Climatic environmental conditions“.

**NOTICE**

**Defect due to continuous splash water !**

- ▶ Never expose the device to continuous splashing water (e.g. direct exposure to rain)!

#### 4.2.4 Control cabinet ventilation

If construction-conditioned the control cabinet cannot be without indoor ventilation, appropriate filters must avoid suction of foreign objects.

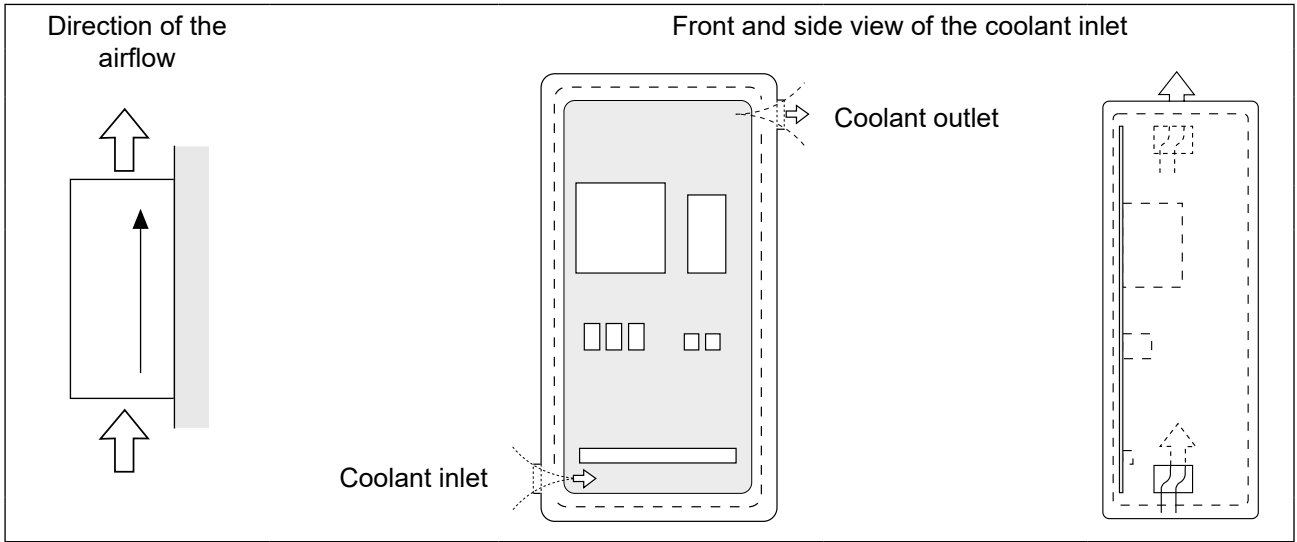
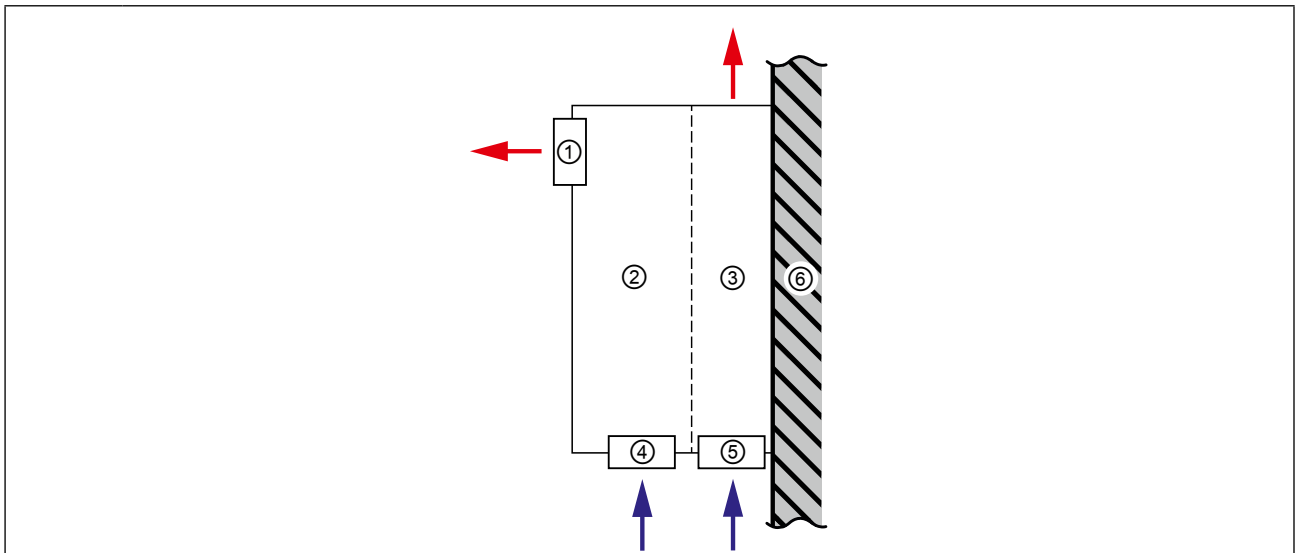

Figure 15: Control cabinet ventilation

#### 4.2.5 Airflow of the drive controller



Legend	
	Airflow direction
1	Interior fan (from housing 4)
2	Drive controller (power unit and control)
3	Drive controller (heat sink)
4	Interior fan for (housing 2 and 3)
5	Heatsink fan
6	Housing (e.g. Control cabinet rear)

Figure 16: Airflow of the drive controller

## 5 Installation and connection

### 5.1 Overview of the COMBIVERT F6

Housing 3		No.	Name	Description
		1	---	Fixing points for the optional shield connection brackets. The shielding e.g. from the motor cable is laid on the mounting plate in the control cabinet or on the shield connection bracket (optionally available).  Control unit: • 00F6V80-2000  Power unit: • 00F6V80-3001
		2	---	LEDs (=> manual for control unit chapter "Overview") • For control board COMPACT: FS without function. • For control card APPLICATION and PRO: Status indication of the safety module
		3	---	Nameplates
		4	PE	Protective earth; at connection to protective earth each terminal may be assigned only once
		5	X1A	Power circuit terminals for: • Mains input • Braking resistor • DC voltage interface • Motor connection
<p>Figure 17: F6 housing 3 top view</p>				

Housing 3		No.	Name	Description
	1	---	Fixing points for the optional shield connection brackets. The shielding e.g. from the motor cable is laid on the mounting plate in the control cabinet or on the shield connection bracket (optionally available).  Power unit: • 00F6V80-3001	
	4	PE	Protective earth; at connection to protective earth each terminal may be assigned only once	
	5	X1A	Power circuit terminals for: • Mains input • Braking resistor • DC voltage interface • Motor connection	
	6	X1C	Terminal for: • Motor temperature monitoring • Brake control	
	7	X3A	Encoder interface channel A	
	8	X3B	Encoder interface channel B	
	9	---	Interior fan	
	10	---	Heat sink fan	
	1			
	1			

Figure 18: F6 housing 3 front view

Housing 3		No.	Name	Description
	11	S1	Rotary coding switch A	
	12	S2	Rotary coding switch B	
	13	X4C	Fieldbus interface (out)	
	14	X4B	Fieldbus interface (in)	
	15	X2B	Safety module	
	16	X2A	Control terminal block for <ul style="list-style-type: none"> <li>• CAN bus</li> <li>• Analog inputs and analog output</li> <li>• Digital inputs and outputs</li> <li>• 24 V DC voltage supply</li> </ul>	

Figure 19: F6 housing 3 rear view with control board APPLICATION



Further information can be found in the respective control board manual.



Instructions for use COMBIVERT F6 control board APPLICATION  
[www.keb.de/fileadmin/media/Manuals/dr/ma\\_dr\\_f6-cu-a-inst-20118593\\_en.pdf](http://www.keb.de/fileadmin/media/Manuals/dr/ma_dr_f6-cu-a-inst-20118593_en.pdf)



Instructions for use COMBIVERT F6 control board COMPACT  
[www.keb.de/fileadmin/media/Manuals/dr/ma\\_dr\\_f6-cu-k-inst-20144795\\_en.pdf](http://www.keb.de/fileadmin/media/Manuals/dr/ma_dr_f6-cu-k-inst-20144795_en.pdf)



Instructions for use COMBIVERT F6 control board PRO  
[www.keb.de/fileadmin/media/Manuals/dr/ma\\_dr\\_f6-cu-p-inst-20182705\\_en.pdf](http://www.keb.de/fileadmin/media/Manuals/dr/ma_dr_f6-cu-p-inst-20182705_en.pdf)



## 5.2 Connection of the power unit

### NOTICE

#### Destruction of the drive controller!

- ▶ Never exchange mains input and motor output!

### 5.2.1 Connection of the voltage supply

The COMBIVERT F6 housing 3 can be supplied via terminals L1, L2 and L3 (AC power supply) or via terminals + and - (DC power supply with inrush current limitation)

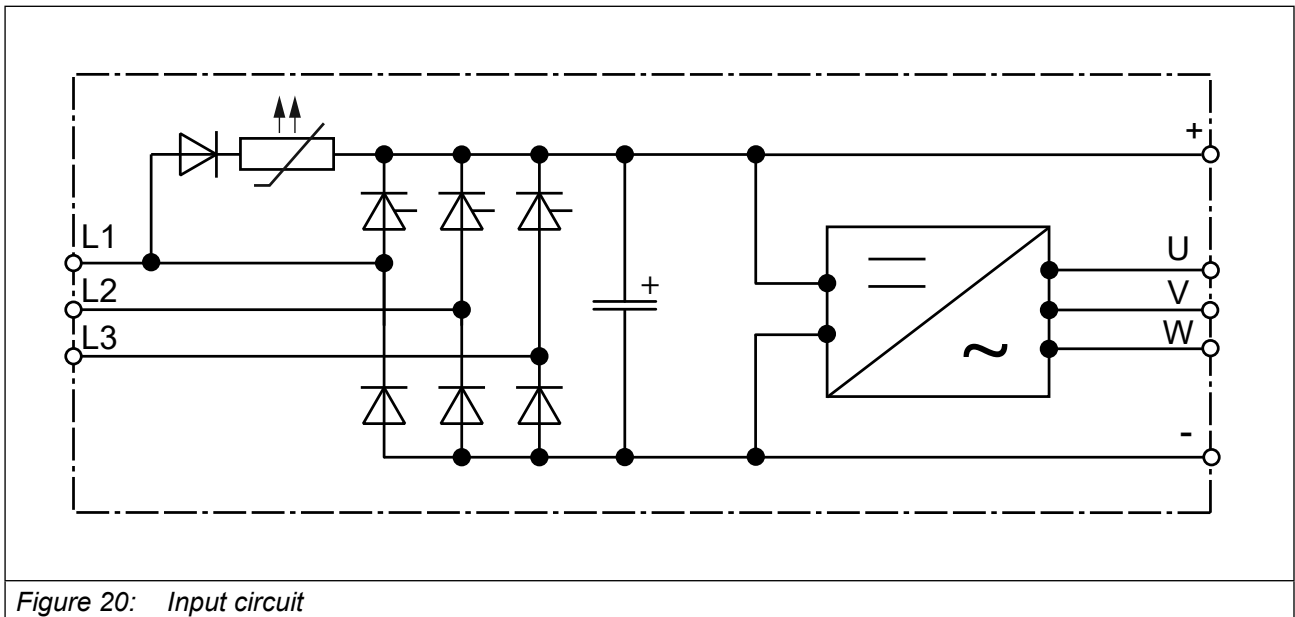

Figure 20: Input circuit

### NOTICE

**With AC power supply, observe the minimum waiting time between two switch-on procedures!**

Cyclical switching off and on of the drive converter leads to temporary high impedance of the PTC precharging resistor. After the PTC precharging resistor has cooled down, it can be restarted without restrictions. The waiting time between two switch-on processes depends on the external capacitance, the AC mains voltage and the ambient temperature.

- ▶ Without external capacity: 5 min
- ▶ With external capacity (additional drive converters): 5 min

### NOTICE

**No inrush current limitation with DC power supply!**

- ▶ An external inrush current limiter must be provided for DC power supplies.

5.2.1.1 Terminal block X1A

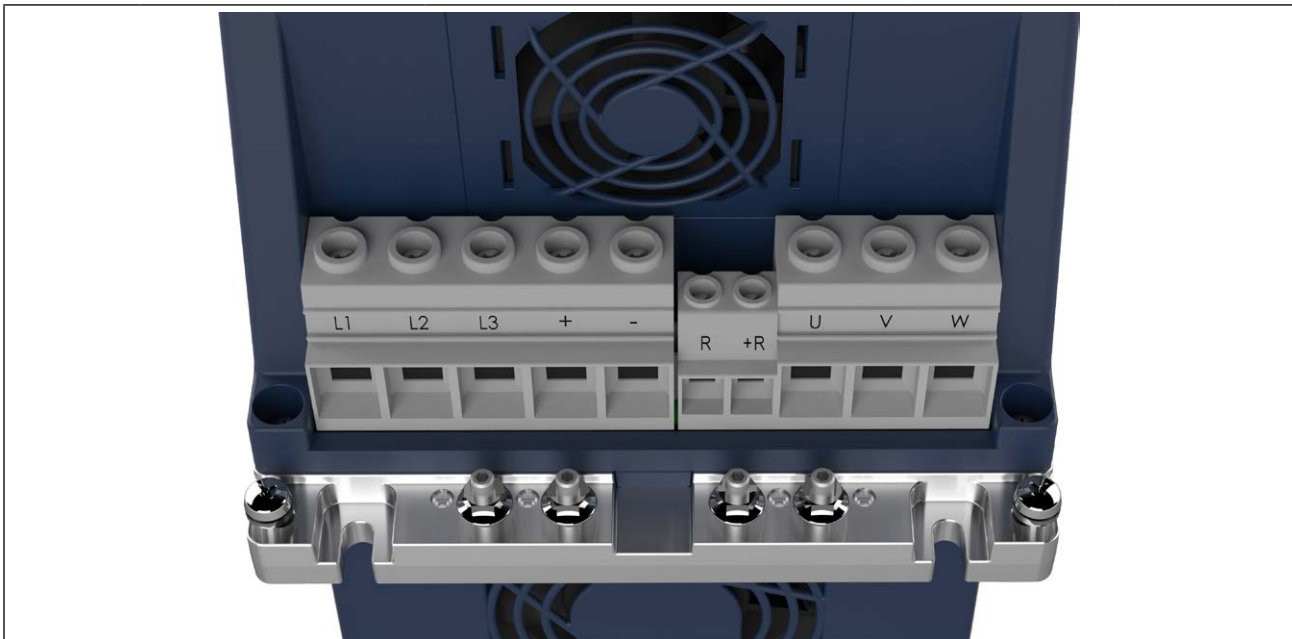

Name	Function	Cross-section for terminal connection	Tightening torque	Max. number of conductors
L1	Mains connection 3-phase	Flexible line with wire-end ferrule 0.5...35 mm <sup>2</sup> With 2 conductors max. 6mm <sup>2</sup>	2.5...4.5 Nm 23...40lb inch	For IEC: 2  For UL: 1
L2				
L3				
+	DC terminals	UL: Flexible line without wire-end ferrule AWG 20...6	1.2...1.5 Nm 11...13lb inch	
-				
R	Connection for braking resistor (between R and +R)	Flexible cable with wire-end ferrule 0.5...16 mm <sup>2</sup> With 2 conductors max. 6mm <sup>2</sup>  UL: Flexible cable without wire-end ferrule AWG 20...6	1.2...1.5 Nm 11...13lb inch	
+R				
U	Motor connection	See terminals L1, L2, L3	See terminals L1, L2, L3	
V				
W				

Figure 21: Terminal block X1A

5.2.2 Protective earth and functional earth



Protective and functional earth must not be connected to the same terminal.

5.2.2.1 Protective earth

The protective earth (PE) serves for electrical safety particularly personal protection in error case.



**Electric shock due to incorrect dimensioning!**



► The earthing cross-section complies with *VDE 0100* !

Name	Function	Terminal connection	Tightening torque
PE,	Connection for protective earth	5 mm threaded pin for M5 crimp connector	6...8 Nm 53...70 lb inch

Figure 22: Connection for protective earth



**Incorrect installation of the PE connection**

Only M5 threaded pins with nut may be used as connection for protective earth!

5.2.2.2 Functional earthing

A functional earthing may also be necessary, if for EMC requirements additional potential equalization between devices or parts of the system must be available.



The use of the functional earth (FE) is not required if the frequency inverter is EMC-technically wired.

The functional earth may not be wired green / yellow!



Notes on EMC-compatible installation can be found here.  
[www.keb.de/fileadmin/media/Manuals/emv/0000neb0000.pdf](http://www.keb.de/fileadmin/media/Manuals/emv/0000neb0000.pdf)



### 5.3 Mains connection

#### 5.3.1 Supply cable

The conductor cross-section of the supply cable is determined by the following factors:

- Input current of the drive controller
- Used line type
- Installation and ambient temperatures
- The locally valid electrical regulations



The application engineer is responsible for the design!

#### 5.3.2 AC mains connection

##### 5.3.2.1 AC supply 3-phase

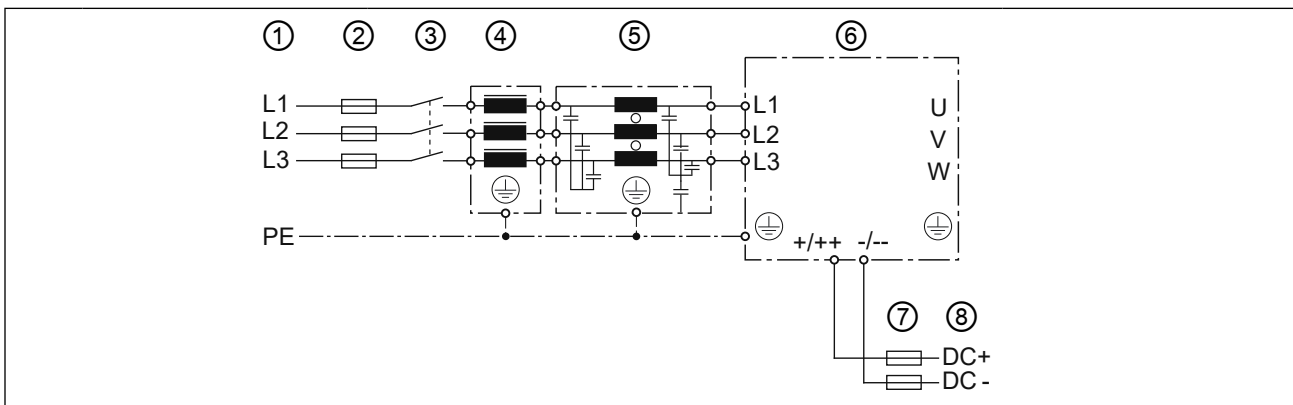

No.	Type	Description	
1	Mains phase	3-phase	
	Mains form	TN, TT	IT
		The rated voltage between one phase conductor and earth potential (or the neutral point in the IT system) must not exceed 300V, USA UL: 480 / 277 V. (For the IT system, a short-term disconnection must be ensured).	
Personal protection	RCMA with separator or RCD type B	Insulation monitors	
2	Mains fuses	see chapter "Protection of the drive controllers"	
3	Mains contactor	-	
4	Mains choke	see notes in chapter "Filters and chokes"	
5	HF filter for TN-, TT systems	Required for compliance with the limit values in accordance with <a href="#">EN 61800-3</a> .	
	HF filter for IT systems		
6	Drive controller	COMBIVERT F6	
7	DC-fuses	See note in chapter „Fusing of the devices“.	
8	DC-supply	DC supply generated by the drive controller for connecting further drive controllers => „5.3.6 DC-bus connection“	

Figure 23: Connection of the mains supply 3-phase

## 5.3.2.2 Note on hard power systems

The service life of drive controllers with voltage DC link depends on the DC voltage, ambient temperature and the current load of the electrolytic capacitors in the DC link. The use of mains chokes can increase the service life of the condensators to a considerable extent, especially when connecting to "hard" power systems or when under permanent drive load (continuous duty).

The term "hard" power system means that the nodal point power ( $S_{Net}$ ) of the mains is very high ( $\gg 200$ ) compared to the rated apparent output power of the drive controller ( $S_{out}$ ).

$k = \frac{S_{Net}}{S_{out}} \gg 200$	e.g.	$k = \frac{2 \text{ MVA (supply transformer)}}{42 \text{ kVA (19F6)}} = 48 \rightarrow$	no choke required
---------------------------------------	------	---	-------------------



A listing of filters and chokes => „5.4.1 Filters and chokes“

**5.3.3 DC mains connection**

**NOTICE**

**DC operation**

- ▶ The DC power supply of 230V devices is only permitted after consultation with KEB!

5.3.3.1 Terminal block X1A DC connection

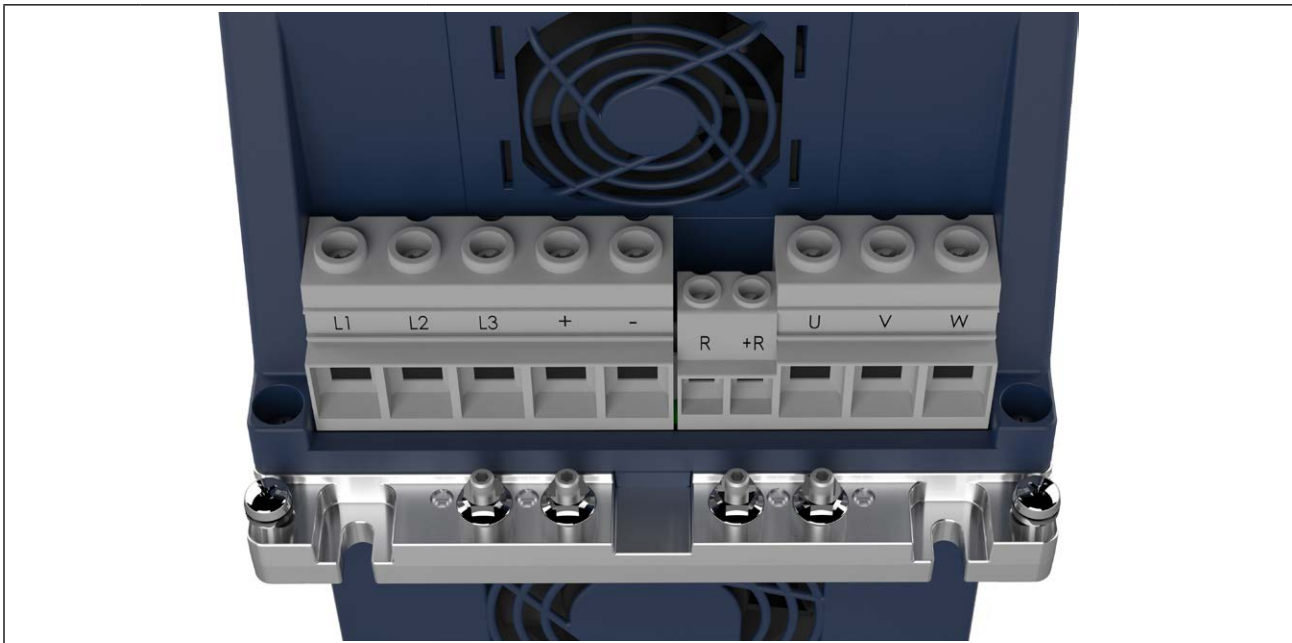

Name	Function	Cross-section for terminal connection	Tightening torque	Max. number of conductors
+	DC terminals	Flexible line with wire-end ferrule 0.5...35 mm <sup>2</sup> With 2 conductors max. 6mm <sup>2</sup>	2.5...4.5 Nm 23...40lb inch	For IEC: 2
-		UL: Flexible line without wire-end ferrule AWG 20...6		For UL: 1

Figure 24: Terminal block X1A DC connection

5.3.3.2 Connection at DC voltage supply

**NOTICE**

**Destruction of the drive controller!**

► Never exchange “+ / ++” and “- / --”!

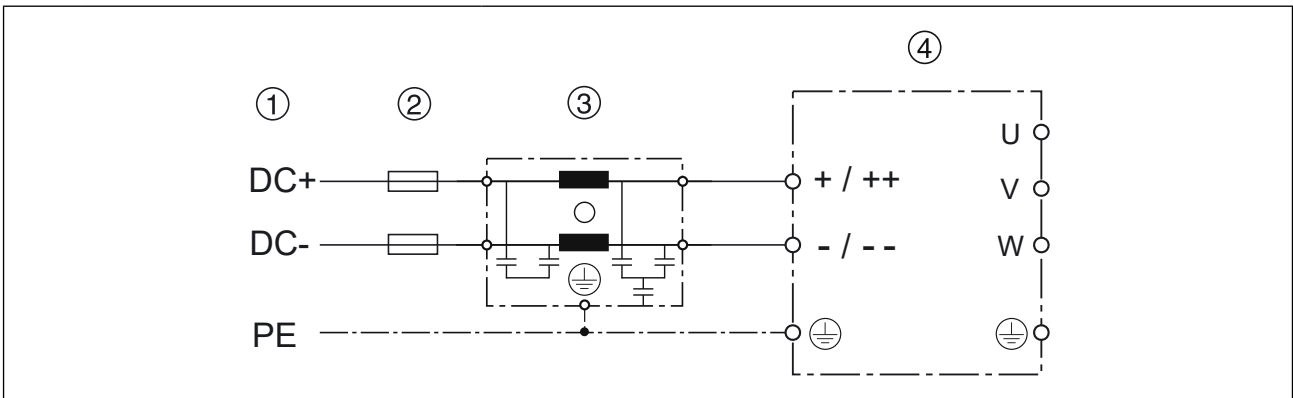

No.	Type	Description
1	Mains connection	2-phase
2	DC mains fuses	See note in chapter “Fuse protection for DC-supply”
3	HF-Filter	Type aR
4	Drive controller	COMBIVERT F6

Figure 25: Connection at DC voltage supply

5.3.4 Connection of the motor

5.3.4.1 Wiring of the motor

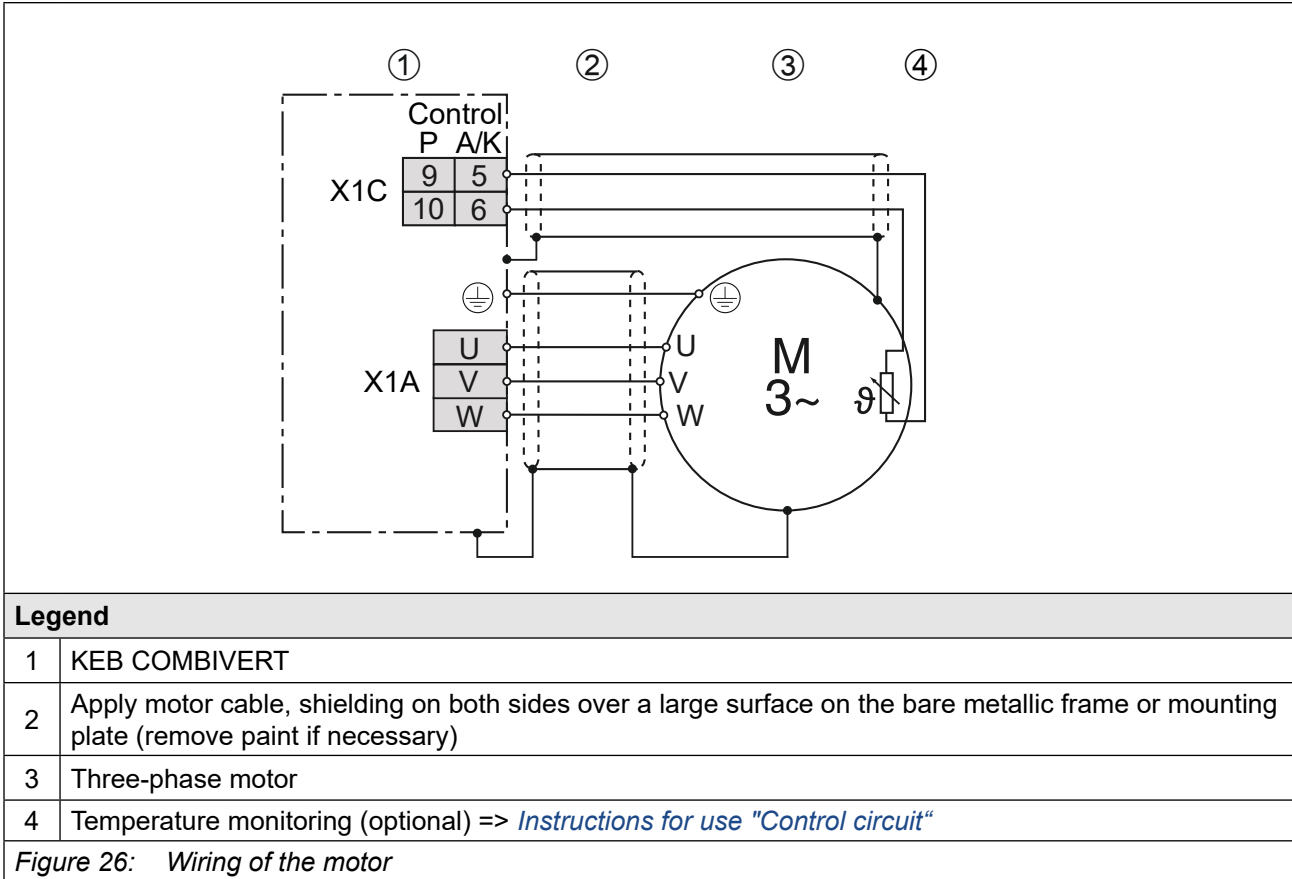
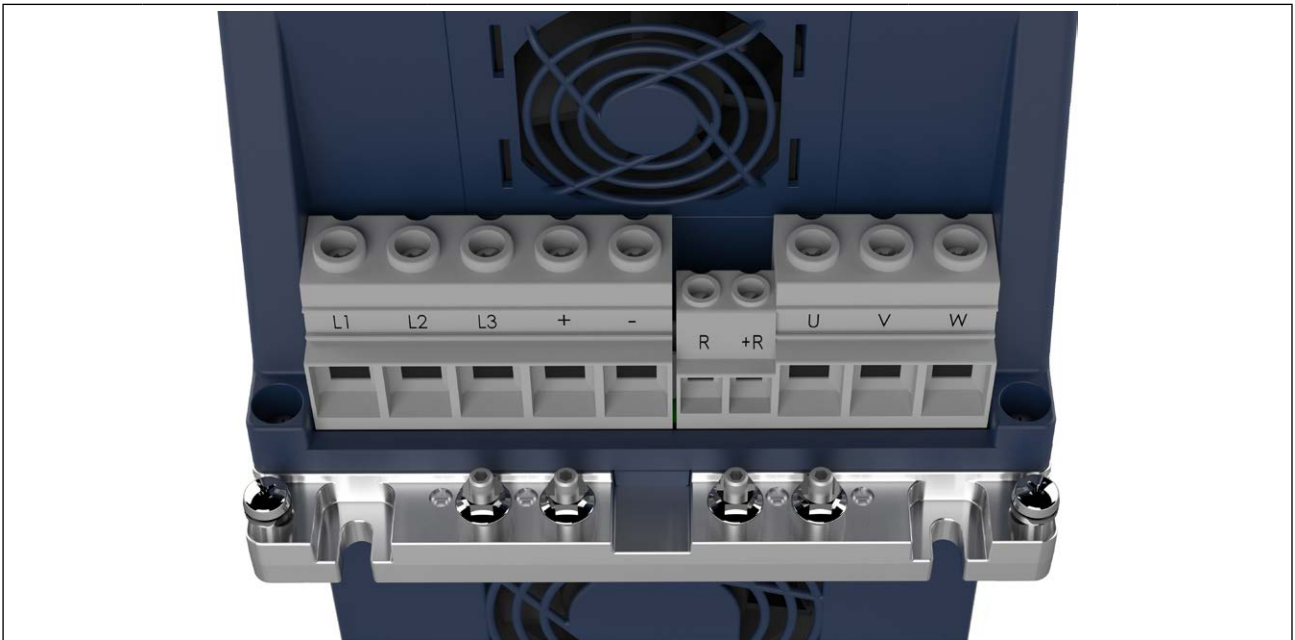

Figure 26: Wiring of the motor

5.3.4.2 Terminal block X1A motor connection



Name	Function	Cross-section for terminal connection	Tightening torque	Max. number of conductors
U	Motor connection	Flexible line with wire-end ferrule 0.5...35 mm <sup>2</sup> With 2 conductors max. 6mm <sup>2</sup>  UL: Flexible line without wire-end ferrule AWG 20...6	2.5...4.5 Nm 23...40 lb inch	For IEC: 2  For UL: 1
V				
W				

Figure 27: Terminal block X1A motor connection

5.3.4.3 Selection of the motor line

The correct cabling as well as the motor line itself play an important part in case of low power in connection with long motor line lengths. Low-capacitance line (phase/phase < 65 pF/m, phase/screen < 120 pF/m) at the inverter output have the following effects:

- allow major motor line lengths („5.3.4.4 Motor cable length and conducted interferences at AC supply“)
- better EMC properties (reduction of the common-mode output currents to earth)

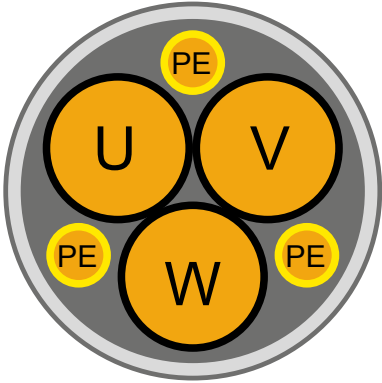
	<p>The use of shielded motor lines with symmetrical structure is required for higher motor power (from 30 kW). In these lines the protective earth conductor is tripartite and evenly arranged between the phase lines. A cable without protective earth conductor can be used if local regulations so permit. Then the protective earth conductor must be laid externally. Certain lines also permit the shield for the use as protective earth conductor. For this, observe the details of the line manufacturer!</p>
<p>Figure 28: Symmetrical motor line</p>	

5.3.4.4 Motor cable length and conducted interferences at AC supply

The maximum motor cable length is depending on the capacity of the motor cable as well as on the EMC emitted interference. External measures must be taken here (e.g. the use of a line filter).

**i** The cable length can be increased significantly by using motor chokes or motor filters. KEB recommends the use of motor chokes or filters for a cable length upto 25m. Motor chokes or filters are absolutely necessary upto 100m.

**i** Further information on the motor cable length can be found in the corresponding filter instructions.

#### 5.3.4.5 Motor cable length for parallel operation of motors

The resulting motor cable length for parallel operation of motors, or parallel installation with multiple cables arises from the following formula:

$$\text{Resulting motor cable length} = \sum \text{single cable length} \times \sqrt{\text{Number of motor cables}}$$

#### 5.3.4.6 Motor cable cross-section

The motor cable cross-section is dependent

- on the characteristic of the output current (e.g. harmonic content)
- on the real effective value of the motor current
- on the cable length
- on the type of the used cable
- on the ambient conditions such as bundling and temperature

#### 5.3.4.7 Interconnection of the motor

### NOTICE

#### Incorrect behaviour of the motor!

- ▶ The connecting-up instructions of the motor manufacturer are always generally valid!

### NOTICE

#### Protect motor against voltage peaks!

- ▶ Drive controllers switch at the output with high  $dV/dt$ . Voltage peaks that endanger the insulation system at the motor can occur especially in case of long motor cables (>15 m). A motor choke, a  $dV/dt$ -filter or sine-wave filter can be used to protect the motor with regard to the operating mode.

5.3.4.8 Connection of the temperature monitoring and brake control (X1C)

A switchable temperature evaluation is implemented in the COMBIVERT.

There are different types for the evaluation available. These are depending on the control board => *Instruction manual „control board“*.

The desired operating mode can be adjusted via software (dr33). If the evaluation is not required, it must be deactivated via software (parameter pn12 = 7) => *Programming manual*.

X1C	PIN	Name	Description
	1	BR+	Brake control / output +
	2	BR-	Brake control / output -
	3	reserved	–
	4	reserved	–
	5	TA1	Temperature detection / output +
	6	TA2	Temperature detection / output -

Figure 29: Terminal block X1C for control board APPLICATION and COMPACT

X1C	PIN	Name	Description
	1	BR+	Brake control / output +
	2	BR-	Brake control / output -
	3	0V	For supply of the checkback inputs
	4	24Vout	
	5	DIBR1	Checkback input 1 for brake and relay
	6	DIBR2	Checkback input 2 for brake and relay
	7	reserved	–
	8	reserved	–
	9	TA1	Temperature detection / output +
	10	TA2	Temperature detection / output -

Figure 30: Terminal block X1C for control board PRO

**NOTICE**

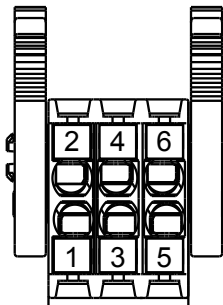
**Malfunctions due to incorrect line or laying!**

**Malfunctions of the control due to capacitive or inductive coupling.**

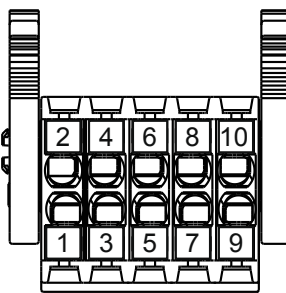
- ▶ Do not route cables from the motor temperature sensor (also shielded) together with control cables.
- ▶ Cables from the motor temperature sensor within the motor cables may only be used with double shielding!
- ▶ The input of the temperature detection has basic isolation.

		<p>For control board APPLICATION and COMPACT. The voltage to the control of a brake is decoupled from the internal voltage supply. The brake works only with external voltage supply.</p> <p>For control board PRO The brake can be supplied with both, internal and external voltage. Voltage tolerances and output currents vary for internal and external voltage supply..</p>
1	COMBIVERT	<p>Respect the specifications =&gt; <a href="#">Instruction manual „control board“</a></p>
4	Brake	
<p>Figure 31: Connection of the brake control</p>		

		<p>KTY sensors are polarized semiconductors and must be operated in forward direction! To this connect the anode to TA1 and the cathode to TA2! Non-observance leads to incorrect measurements in the upper temperature range. A protection of the motor winding is then no longer guaranteed.</p>
1	Connection via shield plate (if not available, place on the mounting plate).	
<p>Figure 32: Connection of a KTY sensor</p>		

**NOTICE**

- No protection of the motor winding in case of wrong connection.**
- ▶ Operate KTY sensors in forward direction.
  - ▶ KTY sensors may not be combined with other detections.



Further information about the wiring of the temperature monitoring and the brake control have to be observed in the respective control unit manual.

### 5.3.5 Connection and use of a braking resistor

**⚠ CAUTION**



**Fire risk by using brake resistors!**

- ▶ The risk of fire can be significantly reduced by using „intrinsically safe braking resistors“ or by using suitable monitoring functions / circuits.

**NOTICE**

**Destruction of the frequency inverter if the value has fallen below the minimum brake resistance value!**

- ▶ The minimum brake resistance value must not fall below!  
*„3.2 Device data of the High Speed Drive devices“*

**⚠ CAUTION**



**Hot surfaces caused by load of the braking resistor!**

**Burning of the skin!**

- ▶ Cover hot surfaces safe-to-touch.
- ▶ Before touching, check the surface.
- ▶ If necessary, attach warning signs on the system.

5.3.5.1 Terminal block X1A connection braking resistor

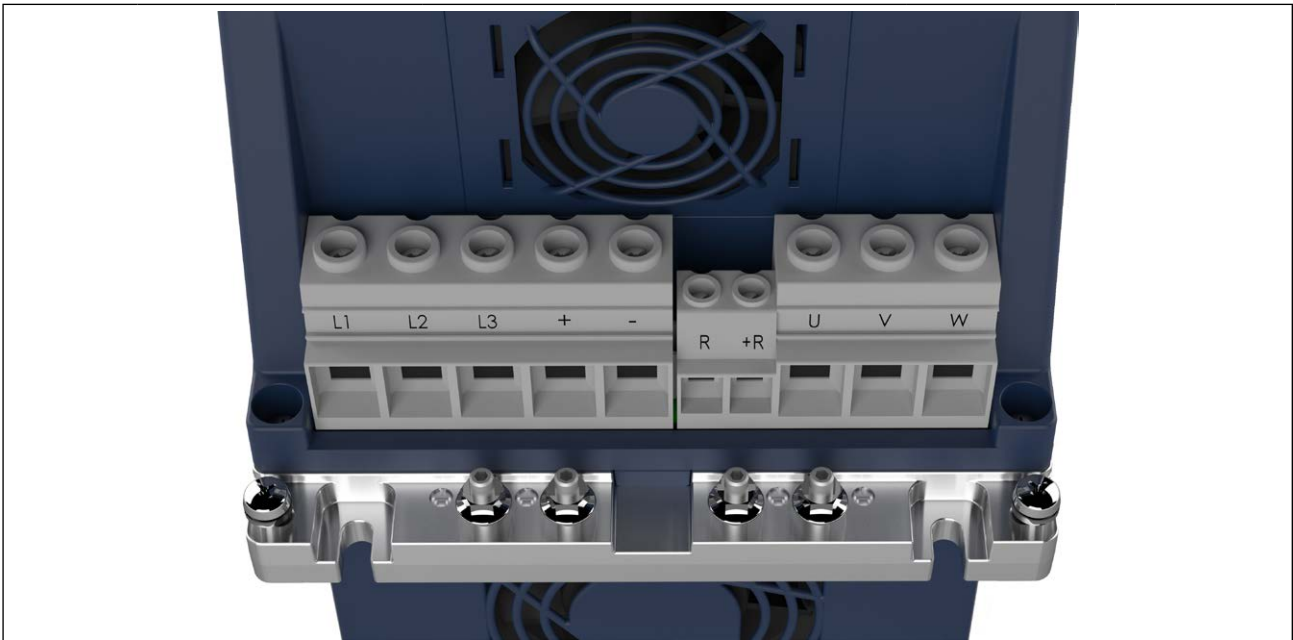

Name	Function	Cross-section for terminal connection	Tightening torque	Max. number of conductors
R	Connection for braking resistor (between R and +R)	Flexible cable with wire-end ferrule 0.5...16 mm <sup>2</sup> With 2 conductors max. 6mm <sup>2</sup>	1.2...1.5 Nm 11...13lb inch	For IEC: 2
+R		UL: Flexible cable without wire-end ferrule AWG 20...6		For UL: 1

Figure 33: Terminal block X1A connection braking resistor

5.3.5.2 Use of intrinsically safe braking resistors

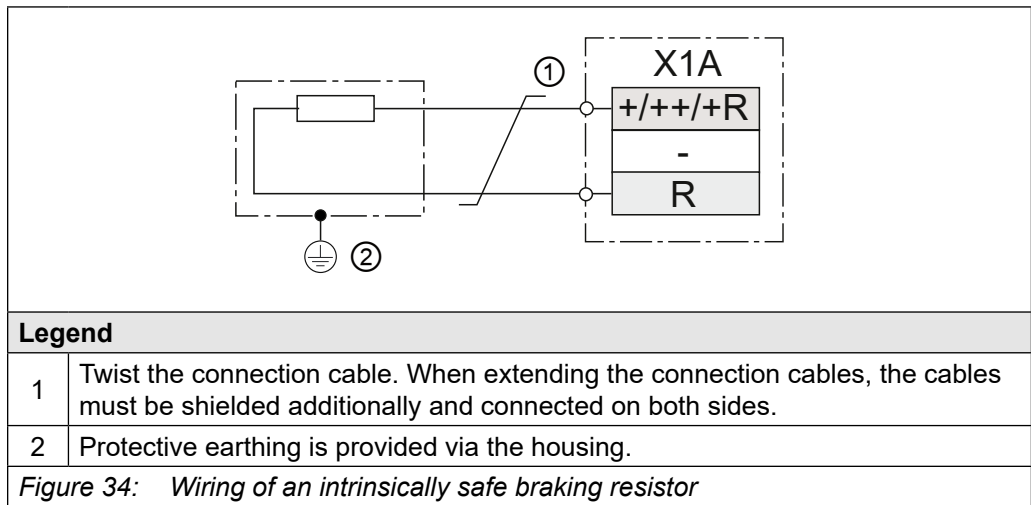

Intrinsically safe braking resistors behave in error case such as a safety fuse. They interrupt themselves without fire risk.

More information about intrinsically safe braking resistors

[www.keb.de/fileadmin/media/Manuals/dr/ma\\_dr\\_safe-braking-resistors-20106652\\_en.pdf](http://www.keb.de/fileadmin/media/Manuals/dr/ma_dr_safe-braking-resistors-20106652_en.pdf)



5.3.5.3 Use of non-intrinsically safe braking resistors

**⚠ WARNING**

**Use of non-intrinsically safe braking resistors**

**Fire or smoke emission in case of overload or error!**



- ▶ Only use braking resistors with temperature sensor.
- ▶ Evaluate temperature sensor.
- ▶ Trigger an error at the drive controller (e.g. external input).
- ▶ Switch off input voltage (e.g. input contactor).
- ▶ Connection examples for non-intrinsically safe braking resistors
- ▶ => *Instructions for use "Installation braking resistors"*



Instructions for use "Installation braking resistors"

[www.keb.de/fileadmin/media/Manuals/dr/ma\\_dr\\_braking-resistors-20116737\\_en.pdf](http://www.keb.de/fileadmin/media/Manuals/dr/ma_dr_braking-resistors-20116737_en.pdf)

Chapter „Connection of a braking resistor with extended temperature monitoring“.



### 5.3.6 DC-bus connection

The DC link of several drive controllers are coupled in a DC-bus connection. This enables energy to be exchanged between the devices and increases the energy efficiency of the application.

As part of a DC-bus connection, this drive controller can either be supplied via the DC terminals => „5.3.3 DC mains connection“ or supply other drive controllers via the DC terminals => „5.3.2 AC mains connection“.



---

KEB drive controllers meet the requirements of the EMC product standard [EN IEC 61800-3](#) for DC power supplies. Due to the large number of possible interconnection options in the DC network, the user is responsible for ensuring the conformity of the overall system.

---

**The following additional safety instructions must be observed when using this drive controller in a DC-bus connection:**

- This drive controller may only be operated together with other F6 and S6 drive controllers of the 400V class in a DC-bus connection.
- This drive controller must be installed in an enclosure.
- This drive controller must be protected with fuses at the DC terminals => „3.2.6.2 Fuse protection for DC supply“.
- If one fuse in the DC-bus connection blows as a result of a short circuit, all fuses in the DC-bus connection should be replaced due to the risk of prior damage.
- The parameterisation of the input phase failure detection must be adapted => F6 Programming manual.

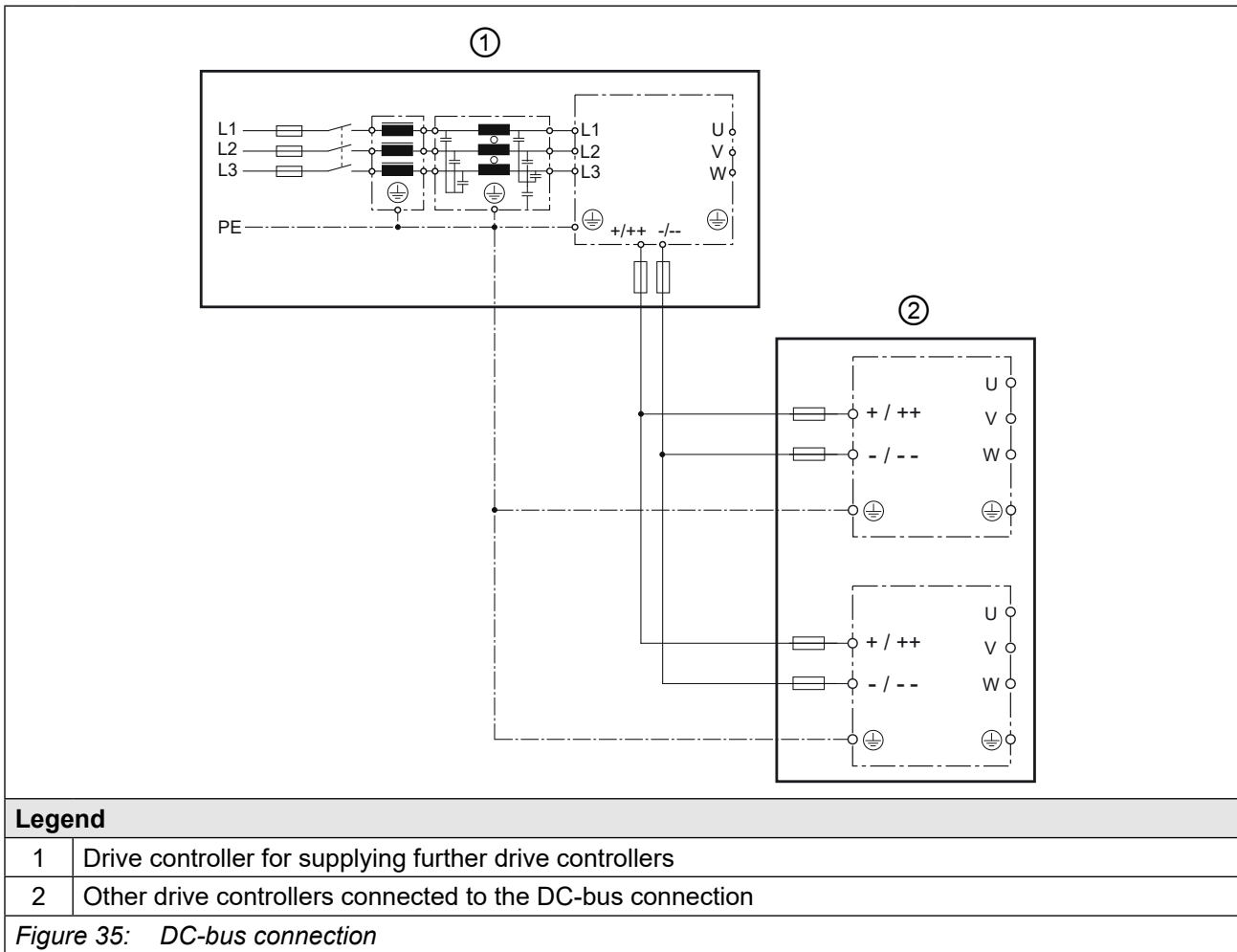

**① When using this drive controller to supply other drive controllers via the DC terminals, the following must also be observed:**

- The maximum prechargeable total capacity (internal capacity + external capacity) must not be exceeded => „[Table 28: DC link / braking transistor function of the HSD devices](#)“.
- The minimum waiting time between two precharging procedures must be observed => „[5.2.1 Connection of the voltage supply](#)“.
- Drive controllers supplied via the DC terminals must not be loaded during precharging.
- Overloading of the rectifier must be prevented by the user => „[3.2.4 Overview of rectifier data for HSD devices](#)“.

**② When supplying this drive controller via the DC terminals, the following must also be observed:**

- The drive controller must be pre-charged by the supplying drive controller or an external pre-charging module.

## 5.4 Accessories

### 5.4.1 Filters and chokes

Voltage class	Drive controller size	HF filter	Mains choke 50 Hz / 4% $U_k$
230 V	15	20E6T60-3000	15Z1B03-1000
	16	20E6T60-3000	16Z1B03-1000
	17	20E6T60-3000	17Z1B03-1000

Table 43: Filters and chokes for 230V devices

Voltage class	Drive controller size	HF filter	Mains choke 50 Hz / 4% $U_k$	
400 V	17	18E6T60-1050	17Z1B04-1000	
		18E6T60-3000		
		18E6T60-3050		
	18	18	18E6T60-1050	18Z1B04-1000
			18E6T60-3000	
			18E6T60-3050	
	19	19	20E6T60-1050	19Z1B04-1000
			20E6T60-3000	
			18E6T60-3050	
	20	20	20E6T60-1050	20Z1B04-1000
			20E6T60-3000	
			18E6T60-3050	

Table 44: Filters and chokes for 400V devices



The specified filters and chokes are designed for rated operation.

### 5.4.2 Seal for IP54-ready devices

Name	Material number
Seal IP54	30F6T45-0004

Table 45: Seal for IP54-ready devices

### 5.4.3 Mounting kit shield connection brackets

Name	Material number
Mounting kit shield connection bracket control unit	00F6V80-2000
Mounting kit shield connection bracket power unit	00F6V80-3001

Table 46: Mounting kit shield connection bracket

#### 5.4.4 Side-mounted braking resistors



Technical data and design about intrinsically safe braking resistors => [https://www.keb.de/fileadmin/media/Manuals/dr/ma\\_dr\\_safe-braking-resistors-20106652\\_en.pdf](https://www.keb.de/fileadmin/media/Manuals/dr/ma_dr_safe-braking-resistors-20106652_en.pdf)



Technical data and design about non-intrinsically safe braking resistors => [https://www.keb.de/fileadmin/media/Manuals/dr/ma\\_dr\\_braking-resistors-20116737\\_en.pdf](https://www.keb.de/fileadmin/media/Manuals/dr/ma_dr_braking-resistors-20116737_en.pdf)



## 6 Operation of Liquid-Cooled Devices

### 6.1 Water-cooled devices

The use of water-cooled KEB COMBIVERT drive converters is offered, because there are process-caused coolants available with some applications. However, the following instructions must be observed.

#### 6.1.1 Heat sink and operating pressure

Design system	Material	max. operating pressure	Connection
Aluminium heat sink	Aluminium -1,67 V	10 bar	=> „6.1.4 Connection of the cooling system“

#### NOTICE

#### Deformation of the heat sink!

- ▶ In order to avoid a deformation of the heat sink and the damages thereby, the indicated maximum operating pressure may not be exceeded briefly also by pressure peaks.
- ▶ Observe the Pressure Equipment Directive 2014/68/EU!

#### 6.1.2 Materials in the cooling circuit

For the screw connections and also for the metallic articles in the cooling circuit which are in contact with the coolant (electrolyte) a material is to be selected, which forms a small voltage difference to the heat sink in order to avoid contact corrosion and/or pitting corrosion (electro-chemical voltage series, see the following table). The specific case of application must be checked by the customer in tuning of the complete cooling circuit and must be classified according to the used materials. With hoses and seals take care that halogen-free materials are used.

A liability for occurring damages by wrongly used materials and from this resulting corrosion cannot be taken over!

Material	formed ion	Standard potential	Material	formed ion	Standard potential
Lithium	Li+	-3.04 V	Nickel	Ni <sup>2+</sup>	-0.25 V
Potassium	K+	-2.93 V	Tin	Sn <sup>2+</sup>	-0.14 V
Calcium	Ca <sup>2+</sup>	-2.87 V	Lead	Pb <sup>3+</sup>	-0.13 V
Sodium	Na+	-2.71 V	Iron	Fe <sup>3+</sup>	-0.037 V
Magnesium	Mg <sup>2+</sup>	-2.38 V	Hydrogen	2H+	0.00 V
<b>Titan</b>	<b>Ti<sup>2+</sup></b>	<b>-1.75 V</b>	<b>Stainless steel (1.4404)</b>	<b>various</b>	<b>0.2...0.4 V</b>
Aluminium	Al <sup>3+</sup>	-1.67 V	Copper	Cu <sup>2+</sup>	0.34 V
Manganese	Mn <sup>2+</sup>	-1.05 V	Carbon	C <sup>2+</sup>	0.74 V
Zinc	Zn <sup>2+</sup>	-0.76 V	Silver	Ag+	0.80 V

*continued on the next page*

Material	formed ion	Standard potential	Material	formed ion	Standard potential
Chrome	Cr <sup>3+</sup>	-0.71 V	Platinum	Pt <sup>2+</sup>	1.20 V
Iron	Fe <sup>2+</sup>	-0.44 V	Gold	Au <sup>3+</sup>	1.42 V
Cadmium	Cd <sup>2+</sup>	-0.40 V	Gold	Au <sup>+</sup>	1.69 V
Cobald	Co <sup>2+</sup>	-0.28 V			

*Table 47: Electrochemical series / standard potentials against hydrogen*

**6.1.3 Requirements for the coolant**

The requirements for the coolant depend on the ambient conditions as well as the used cooling system.

General requirements for the coolant:

Requirement	Description
Standards	Corrosion protection according to <i>EN 12502-1...5</i> , water treatment and use of materials in cooling systems according to <i>VGB S 455 P</i> .
VGB Cooling water directive	The VGB cooling water directive ( <i>VGB S 455 P</i> ) contains instructions about common process technology of the cooling. Particulary the interactions between cooling water and components of the cooling system are described.
Abrasive substances	Abrasive substances as used in abrasive (quartz sand), clogging the cooling circuit.
Hard water	Cooling water may not cause scale deposits or loose excretions. The total hardness should be between 7...20 °dH, the carbon hardness at 3...10 °dH.
Soft water	Soft water (<7°dH) corrodes the material.
Frost protection	An appropriate antifreeze must be used for applications when the heat sink or the coolant is exposed temperatures below zero. Use only products of one manufacturer for a better compatibility with other additives. KEB recommends the antifreeze Antifrogen N from Clariant with a maximum volume content of 52 %.
Corrosion protection	Additives can be used as corrosion protection. In connection with frost protection the antifreeze must have a concentration of 20...25 Vol %, in order to avoid a change of the additives. Alternatively, an antifreeze / glycol with a concentration of 20% ... max. vol 52% can be used. If antifreeze is used, the water does not need to be provided with additional additives.

*Table 48: Requirements for the coolant*

Special requirements for open and half-open cooling systems:

Requirement	Description
Impurities	Mechanical impurities in half-open cooling systems can be counteracted when appropriate water filters are used.
Salt concentration	The salt content can increase through evaporation at half-open systems. Thus the water is more corrosive. Adding of fresh water and removing of process water works against.
Algae and myxobacteria	Algae and myxobacteria can arise caused by increased water temperature and contact with atmospheric oxygen. The algae and myxobacteria clog the filters and obstruct the water-flow. Biocide containing additives can avoid this. Especially at longer OFF periods of the cooling circuit preventive maintenance is necessary.
Organic materials	The contamination with organic materials must be kept as small as possible, because separate slime can be caused by this.

Table 49: Special requirements for open and half-open cooling systems



Damages at the device which are caused by clogged, corroded heat sinks or other obvious operating errors, leads to the loss of the warranty claims.

6.1.4 Connection of the cooling system

The connection to the cooling system can occur as closed or open cooling circuit. The connection to a closed cycle cooling circuit is recommended, because the danger of contamination of coolant is very small. Preferably also a monitoring of the pH value of the coolant should be installed.

Pay attention to a corresponding conductor cross-section at required equipotential bonding in order to avoid electro-chemical procedures.

=> „6.1.2 Materials in the cooling circuit“

Other elements in the cooling circuit such as pumps, shut-off valves, ventilation etc. must be attached according to the cooling system and the local conditions.

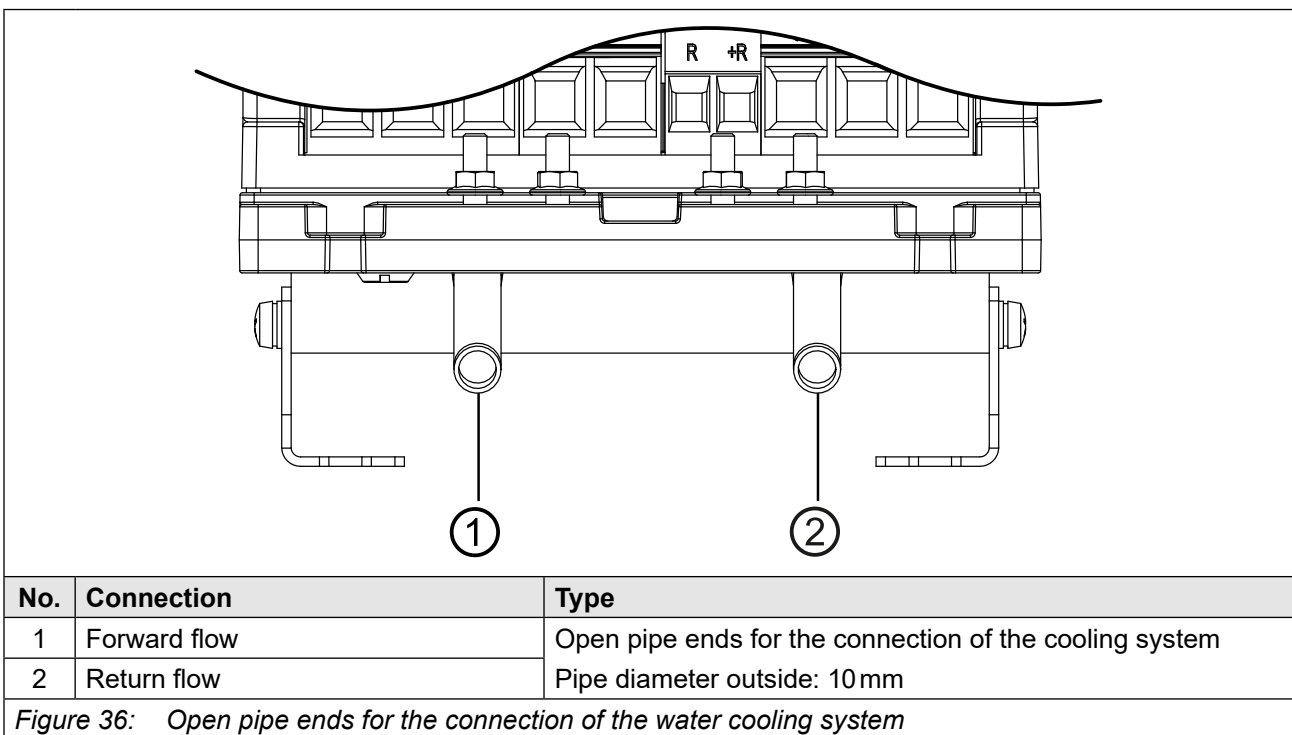

Figure 36: Open pipe ends for the connection of the water cooling system



For the connection of the cooling system KEB recommends the use of functional nuts, e.g. from the manufacturer "Parker", type FMxxL71 (xx = pipe diameter).



In order to monitor the volume flow in the cooling system, KEB recommends the use of a volume flow monitor.

### 6.1.5 Coolant temperature and moisture condensation

The flow temperature should be selected depending on the volume flow so that the heat sink temperature is always 10 K below the overtemperature level (OH) during rated operation. This avoids sporadic shutdown.

The maximum heat sink temperature can be found in chapter => „3.4.1 Switching frequency and temperature“.

#### 6.1.5.1 Condensation

A temperature difference between drive converter and ambient temperature can lead to condensation at high humidity.

Moisture condensation is dangerous for the drive converter. The drive converter can be destroyed through occurring short-circuits.

<b>NOTICE</b>	<b>Destruction of the drive converter due to short circuit!</b>
	▶ Avoid any condensation.

#### 6.1.5.2 Supply of temper coolant

- The supply of optimally tempered coolant is possible by using heaters in the cooling circuit to control the coolant temperature.
- The following dew point table shows the coolant inlet temperature depending on the ambient temperature and air humidity.

Air humidity / %	10	20	30	40	50	60	70	80	90
Ambient temperature / °C									
-10	-34	-26	-22	-19	-17	-15	-13	-11	-11
-5	-29	-22	-18	-15	-13	-11	-8	-7	-6
0	-26	-19	-14	-11	-8	-6	-4	-3	-2
5	-23	-15	-11	-7	-5	-2	0	2	3
10	-19	-11	-7	-3	0	1	4	6	8
15	-18	-7	-3	1	4	7	9	11	13
20	-12	-4	1	5	9	12	14	16	18
25	-8	0	5	10	13	16	19	21	23
30	-6	3	10	14	18	21	24	26	28
35	-2	8	14	18	22	25	28	31	33
40	1	11	18	22	27	31	33	36	38
45	4	15	22	27	32	36	38	41	43
	<b>Coolant inlet temperature / °C</b>								

Table 50: Dew point table



Information on coolant management is given in the following document

[www.keb.de/fileadmin/media/Techinfo/dr/an/ti\\_dr\\_an-liquid-cooling-00004\\_en.pdf](http://www.keb.de/fileadmin/media/Techinfo/dr/an/ti_dr_an-liquid-cooling-00004_en.pdf)



**NOTICE**

**Destruction of the heat sink at storage / transport of water-cooled devices!**

Observe the following points when storing water-cooled devices:

- ▶ Completely empty the cooling circuit
- ▶ Blow out the cooling circuit with compressed air

**NOTICE**

**Destruction of the drive converter due to condensation!**

- ▶ Use only NC valves!

**6.1.6 Permissible volume flow with water cooling**

The volume flow of the following table must be observed.

Permissible volume flow		
Min. volume flow	$Q_{min}$ / l/min	3
Max. volume flow	$Q_{max}$ / l/min	15

Table 51: Permissible volume flow with water cooling



The minimum volume flow depends on the total power dissipation.  
=> „6.1.7 Coolant heating“

**NOTICE**

**Destruction of the heat sink due to erosion!**

- ▶ The maximum permissible volume flow must not be exceeded.

6.1.7 Coolant heating

Volume flow depending on the total power dissipation and temperature difference between forward flow and return flow.

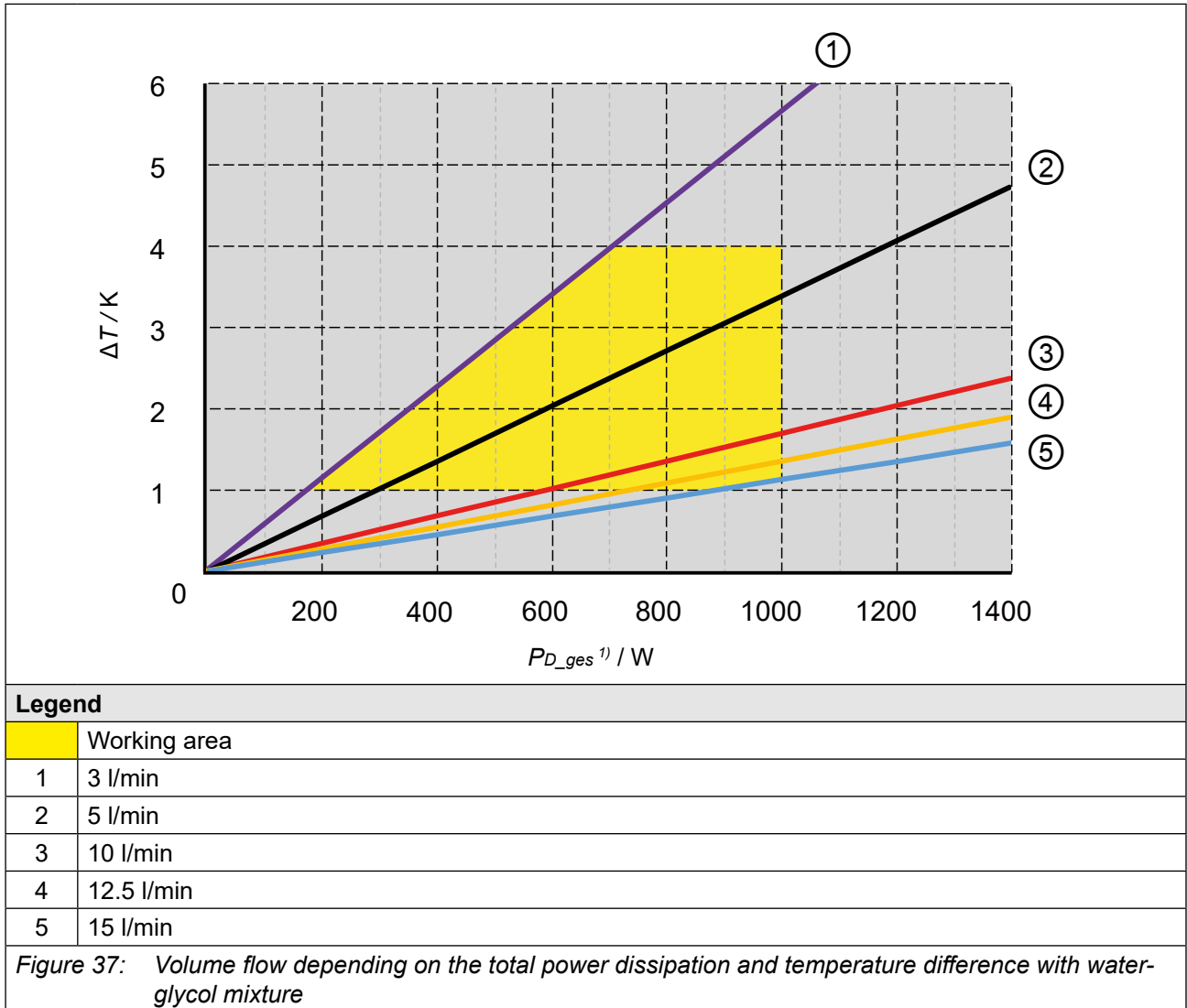

<sup>1)</sup>  $P_{D\_ges}$  can be higher than the power dissipation  $P_D$  at rated operation due to overload, higher switching frequency or sub-mounted braking resistors.

6.1.8 Typical pressure drop of the heat sink

- The curve characteristic shown below applies to a flow temperature of 25 °C and a glycol content of 52 %.
- If higher flow temperatures are used, the pressure drop in the system decreases.
- This also applies to cooling media such as water or another glycol mixture
- A glycol mixture from Clariant in a ratio of 52 % or 33 % is recommended.

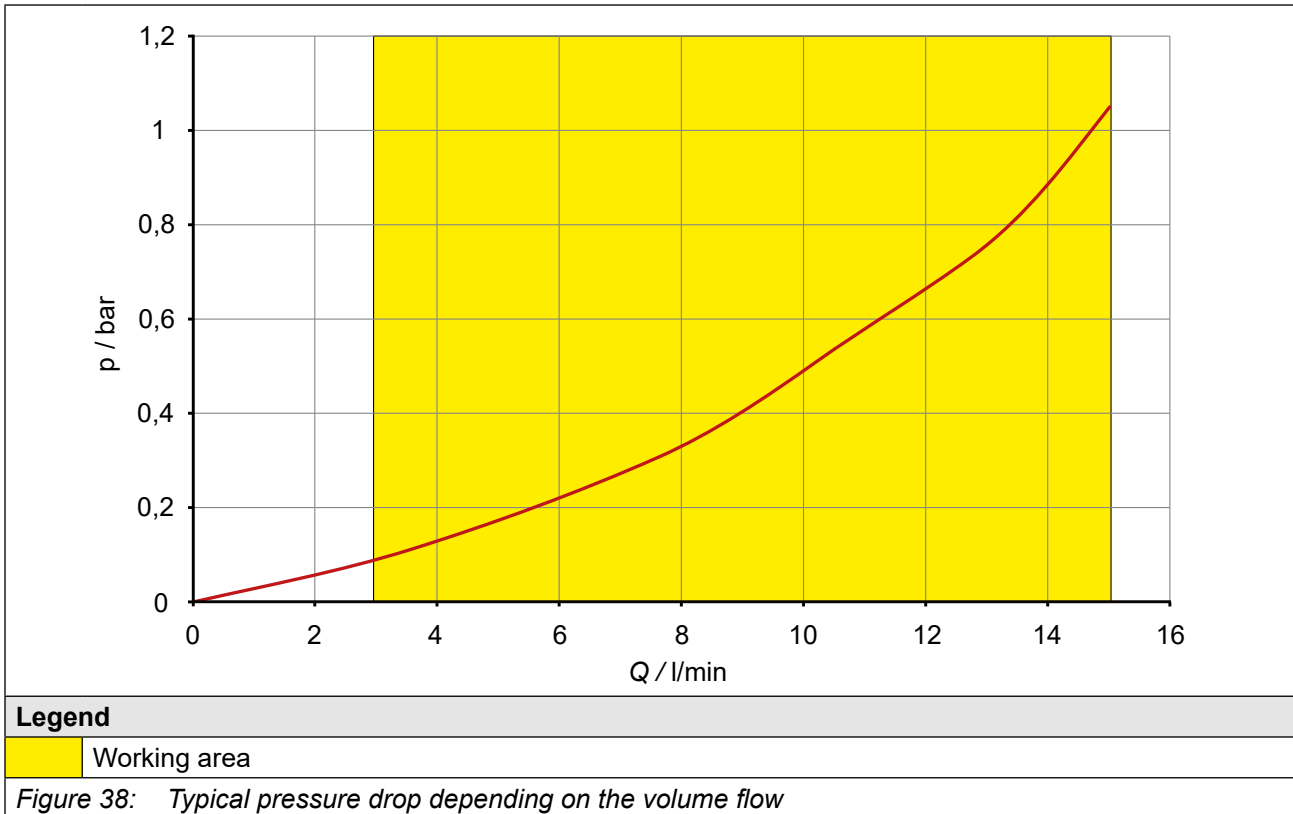

## 7 Approvals and certifications

### 7.1 CE-Marking

The drive converter marked with a CE logo comply with the requirements specified by European Union guidelines. The CE Declaration of Conformity is available on the Internet at [www.keb-automation.com/de/suche](http://www.keb-automation.com/de/suche) .



For further information regarding the CE declarations of conformity

=> „7.3 Further informations and documentation“

---

7.2 UL certification

	Acceptance according to UL is marked at KEB drive controller with the adjacent logo on the nameplate.	UL file number E167544
--	---	---------------------------

To be conform according to UL for use on the North American and Canadian Market the following additionally instructions must be observed (original text of the UL-File):

<ul style="list-style-type: none"> <li>Maximum Surrounding Air Temperature: 45°C</li> </ul>
<ul style="list-style-type: none"> <li>Use 75°C Copper Conductors Only</li> </ul>
<ul style="list-style-type: none"> <li>All 480V ac / 3-ph Models:                      Suitable For Use On A Circuit Capable Of Delivering Not More Than 5000 rms Symmetrical Amperes, 480 Volts Maximum when protected by Class J Fuses, see instruction manual for Branch Circuit Protection details.                       Suitable For Use On A Circuit Capable Of Delivering Not More Than 30000 rms Symmetrical Amperes, 480 Volts Maximum when protected by Semiconductor Fuses by SIBA, Type 20 1xy 20.zz or by Bussmann, Type 170M1xyz or Littelfuse, Type L70QSzzz, see instruction manual for Branch Circuit Protection details.                       Note: “z”, “zz” or “zzz” replace the current rating for the respective type of fuse. “x” may represents different indicators and “y” may represents different fuse connection version.                       When DC supplied:                      Suitable For Use On A Circuit Capable Of Delivering Not More Than 50000 Amperes, 680 Volts DC Maximum when protected by Semiconductor Fuses as Specified in the manual.                 </li> </ul>
<ul style="list-style-type: none"> <li>All 200-240V ac / 3-ph Models:                      Suitable For Use On A Circuit Capable Of Delivering Not More Than 5000 rms Symmetrical Amperes, 240 Volts Maximum when protected by Class J Fuses, see instruction manual for Branch Circuit Protection details.                       Suitable For Use On A Circuit Capable Of Delivering Not More Than 30000 rms Symmetrical Amperes, 240 Volts Maximum when protected by Semiconductor Fuses by SIBA, Type 20 1xy 20.zz or by Bussmann, Type 170M1xyz or Littelfuse, Type L25S zzz, see instruction manual for Branch Circuit Protection details.                       CSA: For Canada, this marking shall be provided on the device or on a separate label shipped with the device. Note: “z”, “zz” or “zzz” replace the current rating for the respective type of fuse. “x” may represents different indicators and “y” may represents different fuse connection versions.                 </li> </ul>

<ul style="list-style-type: none"> <li>•</li> </ul>	<p>Integral solid state short circuit protection does not provide branch circuit protection. Branch circuit protection must be provided in accordance with the Manufacturer Instructions, National Electrical Code and any additional local codes.</p> <p>CSA: For Canada: Integral solid state short circuit protection does not provide branch circuit protection. Branch circuit protection must be provided in accordance with the Canadian Electrical Code, Part I.</p>
<ul style="list-style-type: none"> <li>•</li> </ul>	<p>Control Circuit Overcurrent Protection Required</p>
<ul style="list-style-type: none"> <li>•</li> </ul>	<p>WARNING – The opening of the branch circuit protective device may be an indication that a fault current has been interrupted. To reduce the risk of fire or electrical shock, current-carrying parts and other components of the controller should be examined and replaced if damaged. If burnout of the current element of an overload relay occurs, the complete overload relay must be replaced.</p>
<ul style="list-style-type: none"> <li>•</li> </ul>	<p>All 480V ac / 3-ph Models: Only for use in non-corner grounded type WYE source not exceeding 277 V phase to ground</p> <p>All 200-240V ac / 3-ph Models: Only for use in non-corner grounded type WYE source not exceeding 139 V phase to ground</p>
<ul style="list-style-type: none"> <li>•</li> </ul>	<p>Brake resistor ratings and duty cycle:</p> <ul style="list-style-type: none"> <li>• Duty cycle 50%</li> <li>• Max. 60 sec on-time / 60 sec off-time</li> </ul>
<ul style="list-style-type: none"> <li>•</li> </ul>	<p>The required external control voltage supply shall be marked to indicate a 24Vdc supply voltage.</p>
<ul style="list-style-type: none"> <li>•</li> </ul>	<p>For Use in a Pollution Degree 2 environment. For installations according to Canadian National Standard C22.2 No. 274-13: For use in Pollution Degree 2 and Overvoltage Category III environments only.</p>

### 7.3 Further informations and documentation

You find supplementary manuals and instructions for the download under [www.keb-automation.com/search](http://www.keb-automation.com/search)

#### General instructions

- EMC and safety instructions
- Manuals for additional control boards, safety modules, fieldbus modules, etc.

#### Instruction and information for construction and development

- Input fuses in accordance with UL
- Programming manual for control and power unit
- Motor configurator to select the appropriate drive controller and to create downloads for parameterizing the drive controller

#### Approvals and approbations

- Declaration of conformity CE
- TÜV certificate
- FS certification

Other markings and approvals not listed here are identified by a corresponding logo on the rating plate or device, if applicable. The corresponding certificates are available on our website.

#### Others

- COMBIVIS, the software for comfortable parameterization of drive controllers via PC (available per download)
- EPLAN drawings

## 8 Revision history

Version	Date	Description
00	2017-12	Creation of the pre-series version
01	2019-04	Completion of the series version
02	2020-02	Editorial changes
03	2021-09	Inclusion of 230V and fluid-cooled (water) devices
04	2023-04	Diagram of coolant heating adapted, type code adapted, editorial changes
05	2024-05	Inclusion of DC-Ready devices
06	2025-02	Editorial changes, DC-Ready connection corrected, glossary, standards updated. Drawing for the fluid cooler (water) as built-in version updated.
07	2025-11	Recording of motor protection switches
08	2026-02	Editorial changes.

## Glossary

0V	Earth-potential-free common point	Encoder emulation	Software-generated encoder output
1ph	1-phase mains	End customer	The end customer is the user of the customer product
3ph	3-phase mains	Endat	Bidirectional encoder interface of the company Heidenhain
AC	AC current or voltage	EtherCAT	Real-time Ethernet bus system of the company Beckhoff
AFE	From 07/2019 AIC replaces the previous name AFE	Ethernet	Real-time bus system - defines protocols, plugs, types of cables
AFE filter	From 07/2019 AIC filter replaces the previous name AFE filter	FE	Functional earth
AIC	Active Infeed Converter	FSoE	Functional Safety over Ethernet
AIC filter	Filter for Active Infeed Converter	FU	Drive controller
Application	The application is the intended use of the KEB product	GND	Reference potential, ground
ASCL	Asynchronous sensorless closed loop	GTR7	Braking transistor
Auto motor ident.	Automatically motor identification; calibration of resistance and inductance	HF filter	KEB specific term for an EMC filter (for description see EMC filter).
AWG	American wire gauge	Hiperface	Bidirectional encoder interface of the company Sick-Stegmann
B2B	Business-to-business	HMI	Human machine interface (touch screen)
BiSS	Open source real-time interface for sensors and actuators (DIN 5008)	HSP5	Fast, serial protocol
CAN	Fieldbus system	HTL	Incremental signal with an output voltage (up to 30V) -> TTL
c.d.f.	Cyclic duration factor	IEC	IEC xxxxx stands for an international standard of the International Electrotechnical Commission
CDM	Complete drive module including auxiliary equipment (control cabinet)	IPxx	Protection class (xx for class)
COMBIVERT	KEB drive controller	KEB product	The KEB product is subject of this manual
COMBIVIS	KEB start-up and parameterizing software	KTY	Silicium temperature sensor (polarized)
Customer	The customer has purchased a KEB product from KEB and integrates the KEB product into his product (customer product) or resells the KEB product (dealer)	Manufacturer	The manufacturer is KEB, unless otherwise specified (e.g. as manufacturer of machines, engines, vehicles or adhesives)
DC	DC current or voltage	MCM	American unit for large wire cross sections
DI	Demineralized water, also referred to as deionized (DI) water	Modulation	Means in drive technology that the power semiconductors are controlled
DIN	German Institut for standardization	MTTF	Mean service life to failure
DS 402	CiA DS 402 - CAN device profile for drives	NHN	Standard elevation zero; based on the specified height definition in Germany (DHHN2016). The international data generally deviate from this by only a few cm to dm, so that the specified value can be applied to the regionally applicable definition.
ELV	Extra-low voltage	OC	Overcurrent
EMC filter	EMC filters are used to suppress conducted interferences in both directions between the drive controller and the mains	OH	Overheat
Emergency stop	Shutdown of a drive in emergency case (not de-energized)	OL	Overload
Emergency switching off	Switching off the voltage supply in emergency case		
EMS	Energy Management System		
EN	European standard		

OSSD	Output signal switching device; - an output signal that is checked in regular intervals on its shutdown. (safety technology)
PDS	Power drive system incl. motor and measuring probe
PE	Protective earth
PELV	Protective Extra Low Voltage
PFH	Term used in the safety technology (EN 61508-1...7) for the size of error probability
PFH	Term used in the safety technology (EN 61508-1...7) for the size of error probability per hour
PLC	Programmable logic controller
Pt100	Temperature sensor with $R_0=100\Omega$
Pt1000	Temperature sensor with $R_0=1000\Omega$
PTC	PTC-resistor for temperature detection
PWM	Pulse width modulation
RJ45	Modular connector with 8 lines
SCL	Synchronous sensorless closed loop
SELV	Safe extra-low voltage, unearthed
SIL	The safety integrity level is a measure for quantifying the risk reduction. Term used in the safety technology (EN 61508 -1...7)
SS1	Safety function „Safe stop 1“ in accordance with IEC 61800-5-2
SSI	Synchronous serial interface for encoder
STO	Safety function „Safe Torque Off“ in accordance with IEC 61800-5-2
TTL	Logic with 5 V operating voltage
USB	Universal serial bus
VARAN	Real-time Ethernet bus system

## List of Figures

Figure 1:	Nameplate (exemplary).....	22
Figure 2:	Configurable options.....	23
Figure 3:	Switch-off time $t$ depending on the overload $I/IN$ (OL).....	31
Figure 4:	Typical overload characteristic in the lower output frequencies (OL2) example device size 17.....	32
Figure 5:	Switch-off time $t$ depending on the overload $I/IN$ (OL).....	40
Figure 6:	Typical overload characteristics in the lower output frequencies (OL2) example device size 19.....	41
Figure 7:	Block diagram of the energy flow.....	51
Figure 8:	Switching behaviour of the fans example heat sink fan.....	55
Figure 9:	Dimensions built-in version air cooler.....	56
Figure 10:	Dimensions built-in version fluid cooler (water).....	57
Figure 11:	Dimensions push-through version air cooler IP20, IP54-ready.....	58
Figure 12:	Dimensions push-through versions fluid cooler (water) IP20, IP54-ready.....	59
Figure 13:	Mounting distances.....	61
Figure 14:	Installation of IP54-ready devices.....	62
Figure 15:	Control cabinet ventilation.....	63
Figure 16:	Airflow of the drive controller.....	63
Figure 17:	F6 housing 3 top view.....	64
Figure 18:	F6 housing 3 front view.....	65
Figure 19:	F6 housing 3 rear view with control board APPLICATION.....	66
Figure 20:	Input circuit.....	67
Figure 21:	Terminal block X1A.....	68
Figure 22:	Connection for protective earth.....	69
Figure 23:	Connection of the mains supply 3-phase.....	70
Figure 24:	Terminal block X1A DC connection.....	72
Figure 25:	Connection at DC voltage supply.....	73
Figure 26:	Wiring of the motor.....	74
Figure 27:	Terminal block X1A motor connection.....	75
Figure 28:	Symmetrical motor line.....	76
Figure 29:	Terminal block X1C for control board APPLICATION and COMPACT.....	78
Figure 30:	Terminal block X1C for control board PRO.....	78
Figure 31:	Connection of the brake control.....	79
Figure 32:	Connection of a KTY sensor.....	79
Figure 33:	Terminal block X1A connection braking resistor.....	81
Figure 34:	Wiring of an intrinsically safe braking resistor.....	82
Figure 35:	DC-bus connection.....	84
Figure 36:	Open pipe ends for the connection of the water cooling system.....	90
Figure 37:	Volume flow depending on the total power dissipation and temperature difference with water-glycol mixture.....	93
Figure 38:	Typical pressure drop depending on the volume flow.....	94

## List of Tables

Table 1:	Part code.....	21
Table 2:	Climatic environmental conditions .....	24
Table 3:	Mechanical environmental conditions.....	25
Table 4:	Further environmental operating conditions.....	25
Table 5:	Device classification.....	26
Table 6:	Electromagnetic compatibility .....	26
Table 7:	Overview of the 230 V device data .....	28
Table 8:	Input voltages and frequencies of the 230V devices .....	28
Table 9:	DC link voltage for 230V devices .....	28
Table 10:	Output voltages and frequencies of the 230V devices .....	29
Table 11:	Example of the calculation of the possible motor voltage 230V .....	29
Table 12:	Input currents of the 230 V devices .....	29
Table 13:	Frequency-dependent maximum current for device size 15 .....	33
Table 14:	Frequency-dependent maximum current for device size 16 .....	34
Table 15:	Frequency-dependent maximum current for device size 17 .....	34
Table 16:	Power dissipation of the 230 V devices .....	35
Table 17:	Fusing of the 230V / 240V devices .....	35
Table 18:	Overview of the 400 V device data .....	37
Table 19:	Input voltages and frequencies of the 400V devices .....	37
Table 20:	DC link voltage for 400V devices .....	37
Table 23:	Input and output currents of the 400 V devices .....	38
Table 21:	Output voltages and frequencies of the 400V devices .....	38
Table 22:	Example of the calculation of the possible motor voltage: .....	38
Table 24:	Frequency-dependent maximum current for device size 17 .....	42
Table 25:	Frequency-dependent maximum current for device size 18 .....	43
Table 26:	Frequency-dependent maximum current for device size 19 (2 kHz).....	43
Table 27:	Frequency-dependent maximum current for device size 19 (4 kHz).....	44
Table 28:	Frequency-dependent maximum current for device size 20 .....	44
Table 29:	Overview of rectifier data .....	45
Table 30:	Power dissipation of the 400 V devices .....	46
Table 31:	Fusing of the 400V / 480V devices .....	46
Table 32:	DC-Fusing of the 400V / 480V devices .....	47
Table 33:	Recommended motor protection switches/circuit breakers for 400 V/480 V devices .....	48
Table 34:	Recommended motor protection switches/circuit breakers for 400 V/480 V devices .....	49
Table 35:	Switching frequency and temperature of the 230 V devices.....	50
Table 36:	Switching frequency and temperature of the 400 V devices.....	50
Table 37:	DC link / braking transistor function of the 230V devices .....	52
Table 38:	DC link / braking transistor function of the 400V devices .....	53
Table 39:	Fan.....	54
Table 40:	Switching points of the fans .....	55
Table 41:	Mounting instructions for built-in version.....	60
Table 42:	Mounting instructions for push-through version .....	60
Table 43:	Filters and chokes for 230V devices .....	85

## GLOSSARY

Table 44:	Filters and chokes for 400V devices.....	85
Table 45:	Seal for IP54-ready devices.....	85
Table 46:	Mounting kit shield connection bracket.....	85
Table 47:	Electrochemical series / standard potentials against hydrogen.....	88
Table 48:	Requirements for the coolant.....	88
Table 49:	Special requirements for open and half-open cooling systems.....	89
Table 50:	Dew point table.....	91
Table 51:	Permissible volume flow with water cooling.....	92



**MORE KEB PARTNERS WORLDWIDE:**

[www.keb-automation.com/contact](http://www.keb-automation.com/contact)





**Automation with Drive**

**[www.keb-automation.com](http://www.keb-automation.com)**

KEB Automation KG Suedstrasse 38 D-32683 Barntrop Tel. +49 5263 401-0 E-Mail: [info@keb.de](mailto:info@keb.de)