



COMBIPERM TYPE P1

INSTRUCTIONS FOR USE | INSTALLATION

Translation of the original manual
Document 20229883 EN 06



Preface

The described devices or add-on parts are products of the KEB Automation KG. The enclosed documents correspond to conditions valid at printing. Misprint, mistakes and technical changes reserved.

Signal words and symbols

Certain operations can cause hazards during the installation, operation or thereafter. There are safety informations in the documentation in front of these operations. Security signs are located on the device or machine. A warning contains signal words which are explained in the following table:

⚠ DANGER	Dangerous situation, which will cause death or serious injury in case of non-observance of this safety instruction.
⚠ WARNING	Dangerous situation, which may cause death or serious injury in case of non-observance of this safety instruction.
⚠ CAUTION	Dangerous situation, which may cause minor injury in case of non-observance of this safety instruction.
NOTICE	Situation, which can cause damage to property in case of non-observance.

RESTRICTION

Is used when certain conditions must meet the validity of statements or the result is limited to a certain validity range.



Is used when the result will be better, more economic or trouble-free by following these procedures.

More symbols

- ▶ This arrow starts an action step.
- / - Enumerations are marked with dots or indents.
- => Cross reference to another chapter or another page.



Note to further documentation.
www.keb.de/service/downloads



Laws and guidelines

KEB Automation KG confirms with the EU declaration of conformity and the CE mark on the device nameplate or the signing that it complies with the essential safety requirements.

The EC declaration of conformity can be downloaded on demand via our website.

Warranty and liability

The warranty and liability on design, material or workmanship for the acquired device is given in the general sales conditions.



Here you will find our general sales conditions.
www.keb.de/terms-and-conditions



Further agreements or specifications require a written confirmation.

Support

Through multiple applications not every imaginable case has been taken into account. If you require further information or if problems occur which are not treated detailed in the documentation, you can request the necessary information via the local KEB Automation KG agency.

The use of our units in the target products is outside of our control and therefore lies exclusively in the area of responsibility of the customer.

The information contained in the technical documentation, as well as any user-specific advice in spoken and written and through tests, are made to best of our knowledge and information about the intended use. However, they are regarded as being only informal and changes are expressly reserved, in particular due to technical changes. This also applies to any violation of industrial property rights of a third-party. Selection of our units in view of their suitability for the intended use must be done generally by the user.

Tests can only be done within the intended end use of the product (application) by the customer. They must be repeated, even if only parts of hardware, software or the unit adjustment are modified.

Copyright

The customer may use the instructions for use as well as further documents or parts from it for internal purposes. Copyrights are with KEB Automation KG and remain valid in its entirety.

Other wordmarks or/and logos are trademarks (™) or registered trademarks (®) of their respective owners.

Table of Contents

Preface	3
Signal words and symbols	3
More symbols.....	3
Laws and guidelines.....	4
Warranty and liability.....	4
Support	4
Copyright.....	4
Table of Contents	5
List of Figures	7
List of Tables	7
Glossary	8
Normenverzeichnis	9
1 Basic Safety Instructions	10
1.1 Target group.....	10
1.2 Transport, storage and proper use	10
1.3 Installation and mounting.....	11
1.4 Electrical connection	11
1.5 Start-up and operation	12
1.6 Maintenance.....	13
1.7 Disposal.....	14
2 Product description	15
2.1 Intended use	15
2.2 Residual risks	15
2.3 Improper use.....	15
2.4 Type code.....	15
2.5 Overview COMBIPERM P1.....	17
2.5.1 COMBIPERM Type P1 brake without hub.....	17
2.5.2 COMBIPERM Type P1 brake with armature element - hub neck outside	18
2.5.3 COMBIPERM Type P1 brake with armature element - hub neck inside	19
2.6 Functional description	20
3 Technical data	21
3.1 Operating conditions	21
3.1.1 Climatic environmental conditions.....	21
3.1.2 Mechanical environmental conditions	21
3.1.3 Electrical operating conditions.....	21
3.2 Device data COMBIPERM Type P1.....	22
3.2.1 Overview	22
3.3 Dimensions and weights	23
3.3.1 Magnet with round flange	23

3.3.2 Magnet with square flange	24
3.3.3 Magnet without flange	25
4 Mounting.....	26
4.1 Notes on mounting.....	26
4.2 Mounting the brake	28
4.2.1 Mounting the magnets for brakes.....	28
4.2.2 Example 1: Brake without hub (e.g. 01...10P1-110/210/310-xxxx).....	29
4.2.3 Example 2: Brake with armature element - hub neck outside (e.g. 01...10P1-130/230/330-xxxx).....	30
4.2.4 Example 3: Brake with armature element – hub neck inside (e.g. 01...10P1-120/220/320-xxxx).....	31
5 Electrical connection.....	33
6 Start-up	34
6.1 Inspections prior to start-up of the brake	34
6.1.1 Run in of the brake	34
7 Operation.....	36
8 Troubleshooting.....	37
9 Maintenance and service	38
9.1 Maintenance intervals.....	38
9.2 Service.....	38
9.2.1 Dismount the brake	38
9.2.2 Check air gap	39
9.2.2.1 Checking the air gap X.....	40
9.2.3 Exchange the brake	40
9.2.4 Maintenance running-in of the brake.....	41
10 Disassembly and disposal.....	42
10.1 Disassembly.....	42
10.2 Disposal.....	42
11 Certification.....	43
11.1 EU declaration of conformity.....	43
11.2 CSA Certificat.....	44
12 Revision history.....	47

List of Figures

Figure 1:	COMBIPERM Type P1 brake without hub	17
Figure 2:	COMBIPERM Type P1 brake with armature element - hub neck outside	18
Figure 3:	COMBIPERM Type P1 brake with armature element - hub neck inside.....	19
Figure 4:	Functional description.....	20
Figure 5:	Dimensions COMBIPERM Type P1 Magnet with round flange	23
Figure 6:	Dimensions COMBIPERM Type P1 Magnet with square flange.....	24
Figure 7:	Dimensions COMBIPERM Type P1 Magnet without flange.....	25
Figure 8:	Concentricity k between magnet centering and shaft (armature bore).....	27
Figure 9:	Installation of the magnets.....	28
Figure 10:	Example 1: Brake without hub (e.g. 01...10P1-110/210/310-xxxx)	29
Figure 11:	Example 2: Brake with armature element - hub neck outside (e.g. 01...10P1-130/230/330-xxxx)	30
Figure 12:	Mounting with threaded pin.....	30
Figure 13:	Mounting with shaft-end disc	30
Figure 14:	Example 3: Brake with armature element – hub neck inside (e.g. 01...10P1-120/220/320-xxxx)	31
Figure 15:	Brake with armature element hub neck inside, short type	32
Figure 16:	Brake with armature element hub neck inside, long type	32
Figure 17:	Dismount the brake.....	38
Figure 18:	Checking the air gap.....	40
Figure 19:	CSA Certificat.....	46

List of Tables

Table 1:	Type code	16
Table 2:	Climatic environmental conditions	21
Table 3:	Mechanical environmental conditions.....	21
Table 4:	Device classification.....	21
Table 5:	Device data COMBIPERM Type P1.....	22
Table 6:	Connecting the brake.....	33
Table 7:	Run in of the brake.....	34
Table 8:	Troubleshooting	37
Table 9:	Check air gap.....	39
Table 10:	Maintenance running-in (Refreshment)	41

Glossary

0V	earth-potential-free common point
1ph	1-phase mains
3ph	3-phase mains
AC	AC current or voltage
Application	The application is the intended use of the KEB product.
AWG	American coding for cable cross-sections
B2B	Business-to-business
DC	DC current or voltage
DIN	German Institute for Standardization
EMC	Electromagnetic compatibility
EN	European standard
End customer	The end customer is the user of the customer product.
FE	Functional earth
GND	Reference potential, ground
Manufacturer	The manufacturer is KEB unless otherwise specified (e.g. as a manufacturer of machines, motors, vehicles or adhesives).
IEC	International standard
IP xx	Degree of protection (xx for level)
KEB product	The KEB product is the product which is subject of this manual.
Customer	The customer has purchased a KEB product from KEB and integrates the KEB product into his product (customer product) or resells the KEB product (dealer).
MCM	American measuring unit for large cable cross-sections
MTTF	Mean service life to failure
NN	Sea level
PE	Protective earth
PELV	Safe protective low voltage, earthed
SELV	Safety extra-low voltage, unearthed (<60V)

Normenverzeichnis

VDE 0580	Elektromagnetische Geräte und Komponenten
DGUV Vorschrift 3	Elektrische Anlagen und Betriebsmittel
DIN 46228-1	Aderendhülsen; Rohrform ohne Kunststoffhülse
DIN 46228-4	Aderendhülsen; Rohrform mit Kunststoffhülse
DIN IEC 60364-5-54	Errichten von Niederspannungsanlagen - Teil 5-54: Auswahl und Errichtung elektrischer Betriebsmittel - Erdungsanlagen, Schutzleiter und Schutzpotentialausgleichsleiter (IEC 64/1610/CD)
EN 60204-1	Sicherheit von Maschinen - Elektrische Ausrüstung von Maschinen Teil 1: Allgemeine Anforderungen (VDE 0113-1, IEC 44/709/CDV)
EN 60529	Schutzarten durch Gehäuse (IP-Code) (VDE 0470, IEC 60529)
EN 60664-1	Isulationskoordination für elektrische Betriebsmittel in Niederspannungsanlagen Teil 1: Grundsätze, Anforderungen und Prüfungen (IEC 60664-1)
EN 60721-3-1	Klassifizierung von Umgebungsbedingungen - Teil 3-1: Klassifizierung von Einflussgrößen in Gruppen und deren Grenzwerte - Hauptabschnitt 1: Lagerung (IEC 104/648/CD)
EN 60721-3-2	Klassifizierung von Umweltbedingungen - Teil 3: Klassen von Umwelteinflussgrößen und deren Grenzwerte; Hauptabschnitt 2: Transport (IEC 104/670/CD)
EN 60721-3-3	Klassifizierung von Umweltbedingungen - Teil 3: Klassen von Umwelteinflussgrößen und deren Grenzwerte; Hauptabschnitt 3: Ortsfester Einsatz, wettergeschützt (IEC 60721-3-3)
DIN 748-3	Zylindrische Wellenenden - Teil 3: Für drehende elektrische Maschinen
DIN SPEC 42955	Rundlauf der Wellenenden, Koaxialität und Planlauf der Befestigungsflansche drehender elektrischer Maschinen, Baugröße größer 315 - Toleranzen, Prüfung
DIN EN 50347	Drehstromasynchronmotoren für den Allgemeingebrauch mit standardisierten Abmessungen und Leistungen - Baugrößen 56 bis 315 und Flanschgrößen 65 bis 740; Deutsche Fassung EN 50347
DIN 6885-1	Mitnehmerverbindungen ohne Anzug; Paßfedern, Nuten, hohe Form
DIN 6885-3	Mitnehmerverbindungen ohne Anzug, Passfedern, Nuten, niedrige Form
DIN 332-2	Zentrierbohrungen 60° mit Gewinde für Wellenenden elektrischer Maschinen

1 Basic Safety Instructions

The following safety instructions have been created by the manufacturer for the area of drive technology. They can be supplemented by local, country- or application-specific safety instructions. This list is not exhaustive. Non-observance will lead to the loss of any liability claims.

NOTICE



Hazards and risks through ignorance.

- ▶ Read the instructions for use!
- ▶ Observe the safety and warning instructions!
- ▶ If anything is unclear, please contact KEB!

1.1 Target group

This manual is determined exclusively for technical staff. Technical staff for the purpose of this manual must have the following qualifications:

- Knowledge and understanding of the safety instructions.
- Skills for installation and assembly, start-up, operation and maintenance of the product.
- Understanding of the function in the used machine.
- Detection of hazards and risks of the drive technology.
- Knowledge about work safety and accident prevention (e.g. *DGUV Vorschrift 3*).

1.2 Transport, storage and proper use

The transport is carried out by qualified persons in accordance with the environmental conditions specified in this manual.

Upon delivery the devices are to be checked for visible signs of transport damages. Immediately report transport damages to the transport company and the manufacturer.

Depending on its design and weight appropriate lifting devices must be used for handling.

In case of improper storage, no liability is assumed for resulting damages!

Don't store devices or parts

- in the environment of aggressive and/or conductive liquids or gases.
- with direct sunlight.
- outside the specified environmental conditions.
- in environments that can lead to corrosion and contamination.

1.3 Installation and mounting

NOTICE**Squeezing and pinching of fingers by self-rotation.**

- ▶ Before installation, make sure that the drive is load-free.
- ▶ Secure drive against rotation.

Consider the following installation measures to prevent faults

- ▶ Do not operate the brake in an explosive environment. Consider the following installation measures to prevent faults
- ▶ Measures against freezing and/or formation of ice on the pole surfaces.
- ▶ Take appropriate measures against high air humidity, aggressive vapours/liquids or similar that lead to corrosion and 'rusting' of the pole surfaces.

1.4 Electrical connection

⚠ DANGER**Electrical voltage at brake and motor!****Danger to life due to electric shock!**

- ▶ Only an electrician may work on the electrical power supply.
- ▶ When carrying out any work on the brake, switch off the supply voltage and secure it against switching on.
- ▶ Never bridge upstream protective devices (also not for test purposes).
- ▶ Standardised inspection of the protective earth conductor connection to all exposed metal parts.

1.5 Start-up and operation

The operation must not be started until it is determined that the installation complies with the machine directive; Account is to be taken of *EN 60204-1*.

⚠ CAUTION

Pay attention to friction work (speed and the frequency of operation)!

Loss or drop of the braking torque!

- ▶ Exceeding the technical specifications may result in thermal overload at the braking surface or magnet. This may lead to failure of the brake.

⚠ CAUTION



High temperatures due to braking.

Burning of the skin!

- ▶ Cover hot surfaces safe-to-touch.
- ▶ If necessary, attach warning signs on the system.
- ▶ Check temperature and allow brake to cool down if necessary.

⚠ CAUTION

Rotating Parts.

Shock or crushing of body parts!

- ▶ Wear protective goggles against ejected parts and dirt particles, especially during first start-up.
- ▶ Take measures against being pulled into the machine.

1.6 Maintenance

- ▶ Secure the brake against being switched on accidentally during maintenance work.
- ▶ Make the brake load-free during maintenance work to avoid uncontrolled movements.
- ▶ Protection against the ingress of foreign particles into the air gap. These particles may impede the movement of the armature.
- ▶ When carrying out maintenance and repair work, the brake must not be energised.

In case of malfunction, unusual noises or smells inform a person in charge!

DANGER



Unauthorized exchange, repair and modifications!

Unpredictable malfunctions!

- ▶ The brake must not be converted, modified or misused.
- ▶ Only use original manufacturer parts.
- ▶ Infringement will annul the liability for resulting consequences.

1.7 Disposal

Electronic devices of the KEB Automation KG are exclusively professional devices for further industrial processing (so-called B2B devices).

Manufacturers of B2B devices are obliged to take back and recycle devices manufactured after 14.08.2018. These devices may not be disposed at the collection centres of public sector disposal organisations.



If no deviating agreement has been made between the customer and KEB or no deviating mandatory legal regulation exists, KEB products marked in this way can be returned. Company and keyword to the return point can be taken from the list below. Shipping costs are paid by the customer. Thereupon the devices will be professionally recycled and disposed.

The entry numbers are listed country-specific in the following table. The corresponding KEB return addresses can be found on our website.

Withdrawal by	WEEE-Reg.-No.	Keyword
Austria		
KEB Automation GmbH	ERA: 51976	Stichwort „Rücknahme WEEE“
France		
RÉCYLUM - Recycle point	ADEME: FR021806	Mots clés „KEB DEEE“
Germany		
KEB Automation KG	EAR: DE12653519	Stichwort „Rücknahme WEEE“
Italy		
COBAT	AEE: (IT) 19030000011216	Parola chiave „Ritiro RAEE“
Spain		
KEB Automation KG	RII-AEE 7427	Palabra clave „Retirada RAEE“
Česko		
KEB Automation KG	RETELA 09281/20 ECZ	Klíčové slovo: Zpětný odběr OEEZ
Slowakei		
KEB Automation KG	ASEKOL: RV22EEZ0000421	Klíčové slovo: "Spätný odber OEEZ"

The packaging must be feed to paper and cardboard recycling.

2 Product description

The COMBIPERM type P1 brake is an electro-magnetic released brake for dry running, whose force flow is generated by permanent magnets.

COMBIPERM P1 are powerful permanent-magnet brakes with frictional engagement and backlash-free effect. Rare earth magnets generate a force field which is cancelled (opened) by the counter-pole magnet coil in power on status and in conjunction with the diaphragm spring on the armature element it ensures residual torque-free separation regardless of the installation position.

2.1 Intended use

Permanent-magnet brakes are used for safe braking of masses.

The operational reliability of the brake is only guaranteed when used according to specified application. In this context, specified application means that the brake is used for the ordered and confirmed purpose.

Any other use is considered a breach of specified application. It may pose unforeseeable risks and is solely and exclusively the responsibility of the operating company.

Technical data and information for connection conditions shall be taken from the instructions for use and must be strictly observed. Any use beyond the technical specifications is also considered as not specified.

The actual use of the brake in the target products is beyond KEB Automation KG's control and, therefore, shall be exclusively within the operating company's responsibility.

Restriction

If the product is used in machines which work under exceptional conditions or if essential functions, life-supporting measures or an extraordinary safety step must be fulfilled, the necessary reliability and security must be ensured by the machine builder.

2.2 Residual risks

The brake may overheat due to wrong design or changed operating requirements. This may lead to failure of the brake.

2.3 Improper use

Improper use exists, if

- the product is operated outside the limit values specified in the technical data.
- unauthorized structural changes have been made to the brake.
- improper repairs have been carried out.
- the product has been incorrectly installed or serviced.

In case of infringements, the brake loses its EU conformity and the liability claims against KEB Automation KG expire.

2.4 Type code

The type designation and the version can be found on the nameplate or on the marking.

PRODUCT DESCRIPTION

xx	P1	xxx	-xxx		
			Version		Customer versions
			Type		110: Magnet with round flange, armature element without hub
					120: Magnet with round flange, armature element with hub neck inside
					130: Magnet with round flange, armature element with hub neck outside
					210: Magnet with square flange, armature element without hub
					220: Magnet with square flange, armature element with hub neck inside
					230: Magnet with square flange, armature element with hub neck outside
					310: Magnet without flange, armature element without hub
					320: Magnet without flange, armature element with hub neck inside
					330: Magnet without flange, armature element with hub neck outside
			Series	COMBIPERM Type P1	
			Size	01...10	
<i>Table 1: Type code</i>					

2.5 Overview COMBIPERM P1

2.5.1 COMBIPERM Type P1 brake without hub

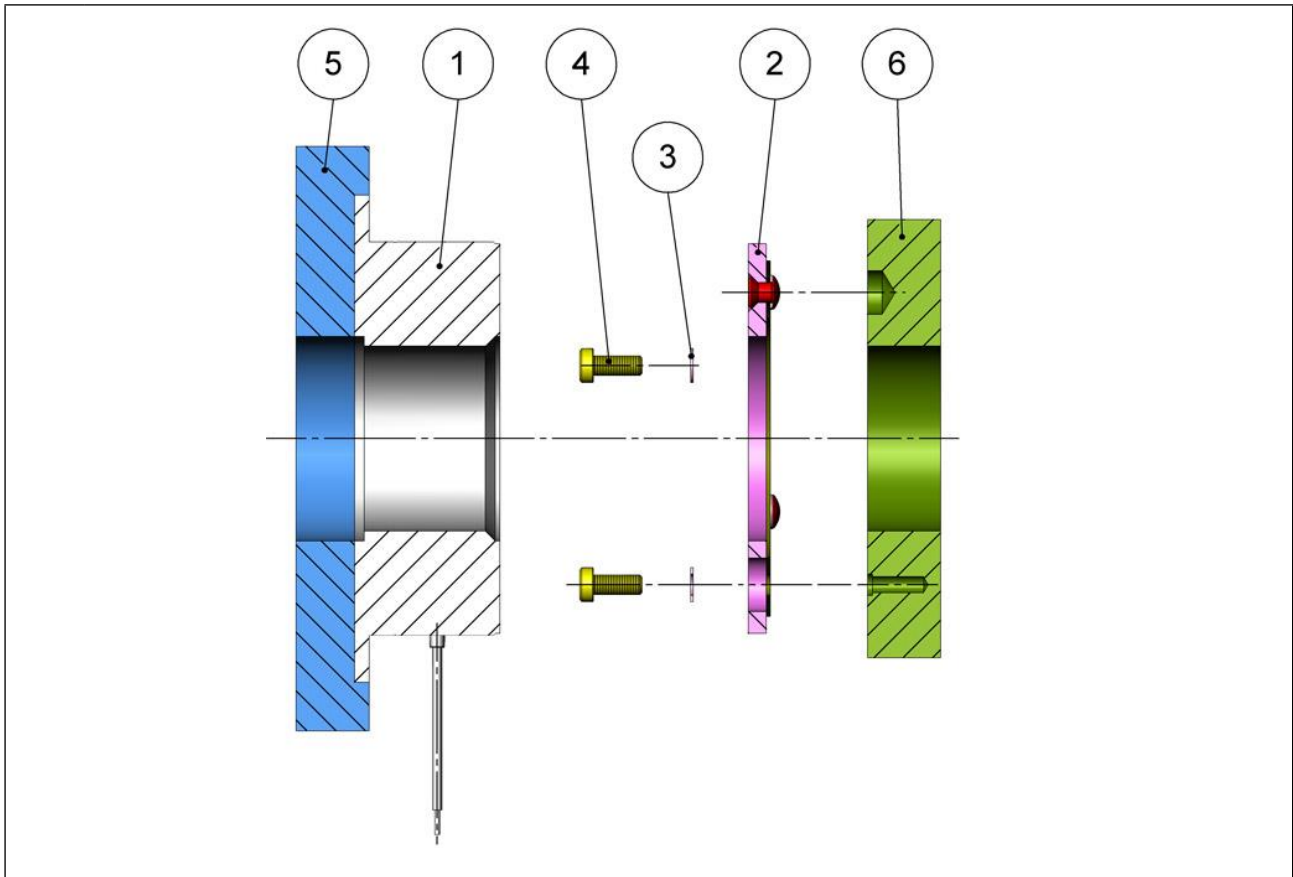

Legend

1	Magnet
2	Armature element without hub
3	Schnorr-lock washers
4	Socket head screws (e. g. DIN 6912)
5	Mounting surface (e.g. motor)
6	Mounting surface evaluated by the customer (e.g. belt pulley, pinion etc.)

Figure 1: COMBIPERM Type P1 brake without hub

2.5.2 COMBIPERM Type P1 brake with armature element - hub neck outside

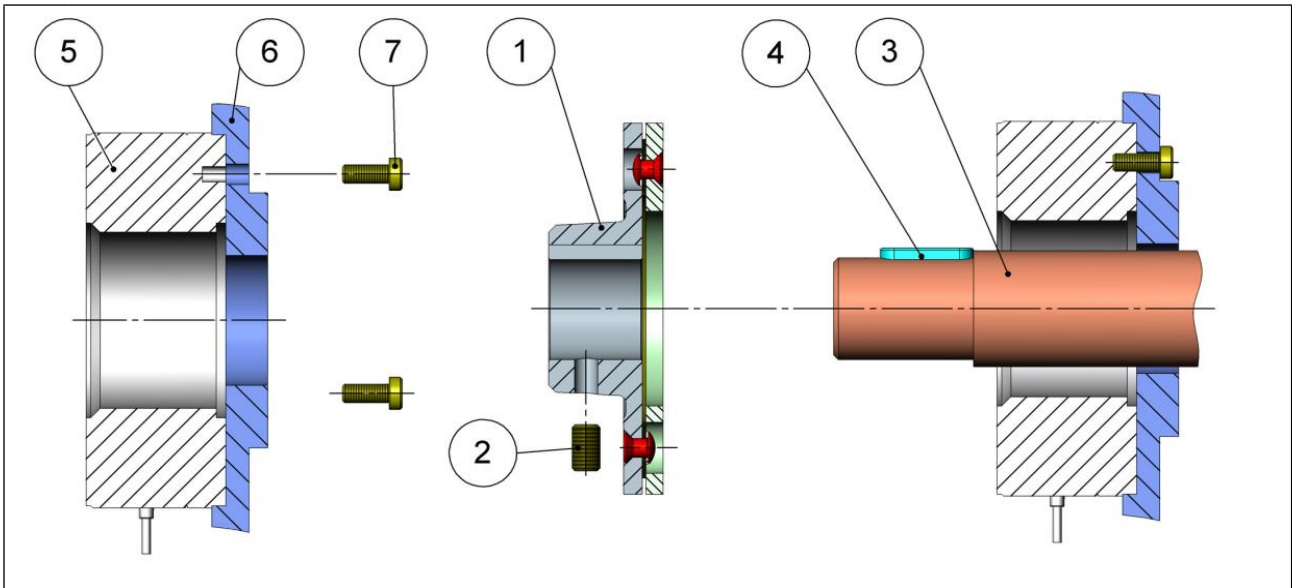

Legend

1	Armature element hub neck outside
2	Threaded pin
3	Motor shaft
4	Feather key for shaft
5	Magnet
6	Motor flange
7	Socket head screw

Figure 2: COMBIPERM Type P1 brake with armature element - hub neck outside

2.5.3 COMBIPERM Type P1 brake with armature element - hub neck inside

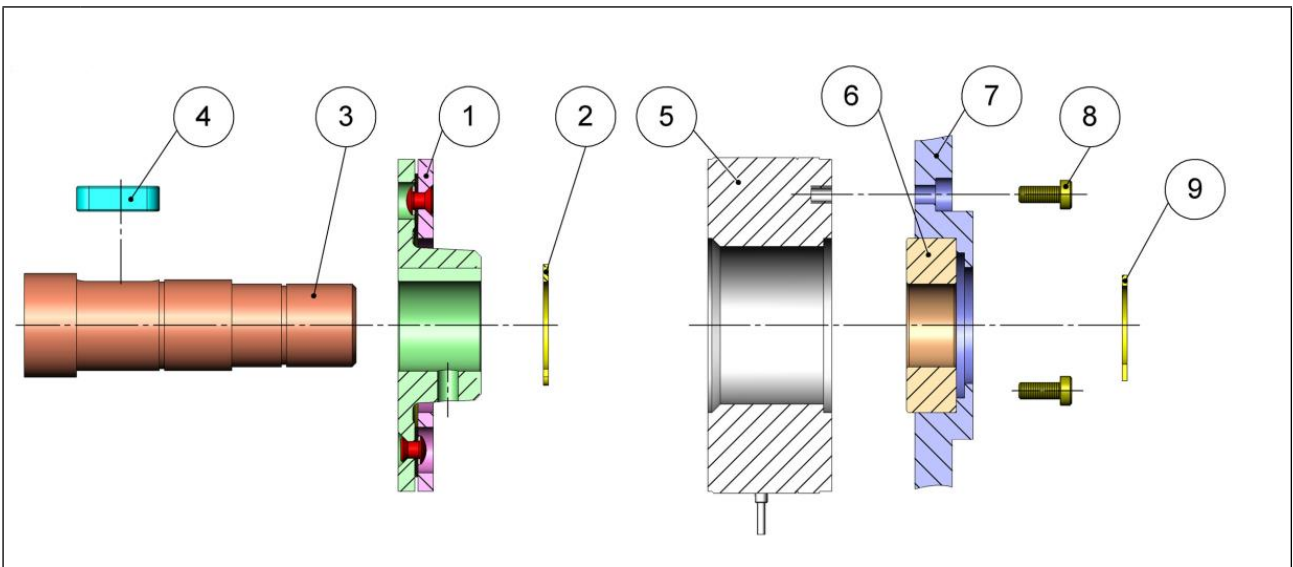

Legend

1	Armature element hub neck inside
2	Retaining ring for shaft
3	Motor shaft
4	Feather key for shaft
5	Magnet
6	Motor ball bearing
7	Motor flange
8	Socket head screw
9	Retaining ring for shaft

Figure 3: COMBIPERM Type P1 brake with armature element - hub neck inside

2.6 Functional description

The force action of a permanent magnetic field is used in power-off condition for torque buildup, whereupon the armature plate is drawn to the magnet. The result is a frictionally engaged, torsional backlash-free connection.

By supplying a pole-correct rated voltage of 0.90 x rated voltage to 1.06x rated voltage, the permanent magnetic field is displaced and, in conjunction with the diaphragm spring on the armature part, the friction surfaces are separated without residual torque regardless of the installation position.

The torque can be enhanced up to 1.3-fold of the rated torque by polarity change. Machine parts made of magnetic material which are close to the magnet can weaken the torque and result in a change of the release range. The brake must be adjusted in this case.

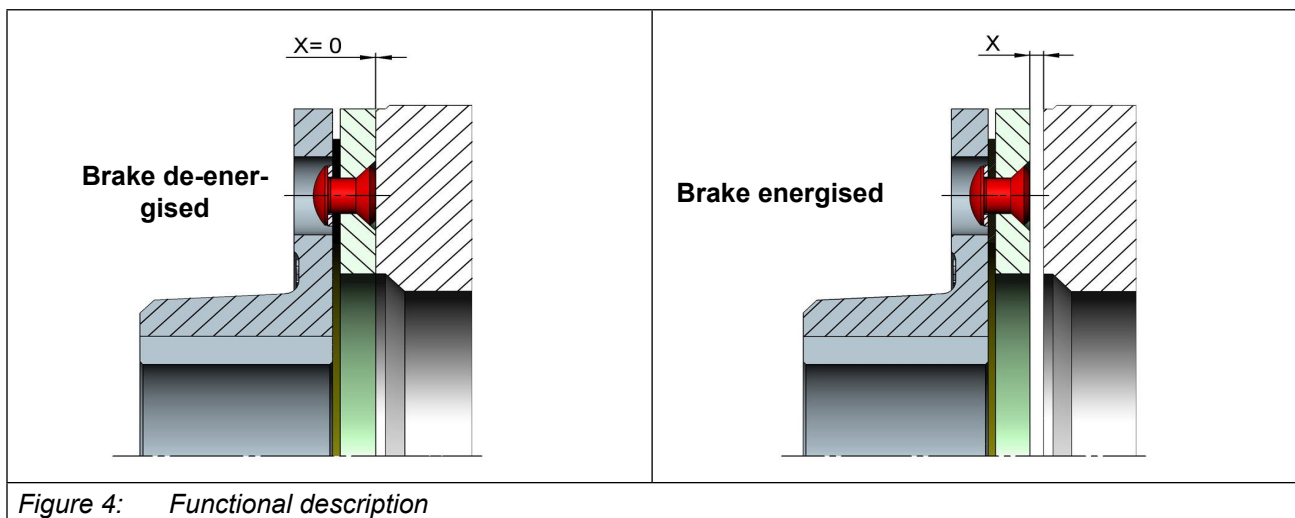

3 Technical data

3.1 Operating conditions

3.1.1 Climatic environmental conditions

Storage	Standard	Class	Notes
Ambient temperature	EN 60721-3-1	1K4	-25...55 °C
Relative humidity			<50% (without condensation)
Storage height	–	–	Max. 3000 m above sea level
Transport	Standard	Class	Notes
Ambient temperature	EN 60721-3-2	2K2	-25...60 °C
Relative humidity	EN 60721-3-2	2K3	95% at 40 °C (without condensation)
Operation	Standard	Class	Notes
Ambient temperature	EN 60721-3-3	3K3	(optional -40...+120 °C)
Relative humidity	EN 60721-3-3	3K3	5...85% (without condensation)
Construction and degree of protection	EN 60529	IP40	
Site altitude	–	–	Max. 2000 m above sea level

Table 2: Climatic environmental conditions

3.1.2 Mechanical environmental conditions

Storage	Standard	Class	Notes
Vibration limits	EN 60721-3-3	1M2	Vibration amplitude 0.3 mm (2...9 Hz) Acceleration amplitude 1 m/s ² (9...200 Hz)
Shock limit values	EN 60721-3-3	1M2	40 m/s ² ; 22 ms
Transport	Standard	Class	Notes
Vibration limits	EN 60721-3-2	2M1	Vibration amplitude 3.5 mm (2...9 Hz) Acceleration amplitude 10 m/s ² (9...200 Hz)
Shock limit values	EN 60721-3-2	2M1	100 m/s ² ; 11 ms

Table 3: Mechanical environmental conditions

3.1.3 Electrical operating conditions

Requirement	Standard	Class	Notes
Overvoltage category	EN 60664-1	III	–

Table 4: Device classification

3.2 Device data COMBIPERM Type P1

3.2.1 Overview

Device size		01	02	03	05	06	07	08	09	10	
Characteristic torque after run in	M_2 / Nm	0,5	1,4	2,7	6,1	12	24	49	96	194	
Min. static torque at 120 °C	$M_{4\text{min}120^\circ\text{C}} / \text{Nm}$	0,3	0,8	1,8	4	8	15	32	65	115	
Rated power at 20°C	P_{20} / W	8	10	11	12	18	24	26	40	50	
Rated voltage	$U_{N\text{dc}} / \text{V}$	24									
Cyclic duration factor	c.d.f. / %	100									
Friction work up to 0.1 mm abrasion	$W_{R0.1} / \text{rpm}$	3000				2000					
	$W_{R0.1} / \text{kgm}^2$	0,001				0,0015	0,004	0,0120	0,036	0,1	
	$W_{R0.1} / \text{kJ}$	200	300	410	580	890	1290	2900	6200	13000	
Max. operating speed	$n_{\text{max}} / \text{rpm}$	10000							8000		
Max. braking speed	$n_{B\text{max}} / \text{rpm}$	6000							4800		
Mass moment of inertia Armature element P1.110	$J / 10^{-4}\text{kgm}^2$	0,01	0,014	0,045	0,122	0,37	1,15	4	11,5	39	
Mass moment of inertia Armature element P1.120/130	$J / 10^{-4}\text{kgm}^2$	0,013	0,021	0,068	0,18	0,54	1,66	5,56	16	53	
Air gap	$X_{\text{min}} / \text{mm}$	0,15	0,15	0,15	0,2	0,3	0,3	0,35	0,4	0,5	
Max. air gap at 20°C	$X_{\text{max}20} / \text{mm}$	0,3	0,3	0,4	0,5	0,65	0,8	0,8	1,0	1,2	
Max. air gap at 120°C	$X_{\text{max}120} / \text{mm}$	0,25	0,25	0,35	0,45	0,55	0,7	0,7	0,8	1,1	
Response delay DC	¹⁾ $t_{11\text{dc}} / \text{ms}$	≤ 2.5	≤ 2	≤ 3	≤ 3	≤ 3	≤ 3	≤ 7	≤ 10	≤ 15	
Response delay AC	¹⁾ $t_{11\text{ac}} / \text{ms}$	≤ 10	≤ 10	≤ 12	≤ 25	≤ 40	≤ 35	≤ 60	≤ 100	≤ 135	
Connection time DC	²⁾ $t_{1\text{dc}} / \text{ms}$	≤ 9	≤ 12	≤ 15	≤ 20	≤ 30	≤ 30	≤ 35	≤ 40	≤ 100	
Separation time	³⁾ t_2 / ms	≤ 10	≤ 20	≤ 40	≤ 50	≤ 70	≤ 90	≤ 135	≤ 200	≤ 240	
Feather key		according to <i>DIN 6885-1</i>									
Keyway		according to <i>DIN 6885-1</i>									
ISO class		F (optional H possible)									

Table 5: Device data COMBIPERM Type P1

- ¹⁾ Time from switching off the current to the increase of the torque.
- ²⁾ Time from switching off the current until reaching 0.9 M_{2N} .
- ³⁾ Disengagement time from power-on to the beginning of the torque drop.

3.3 Dimensions and weights

3.3.1 Magnet with round flange

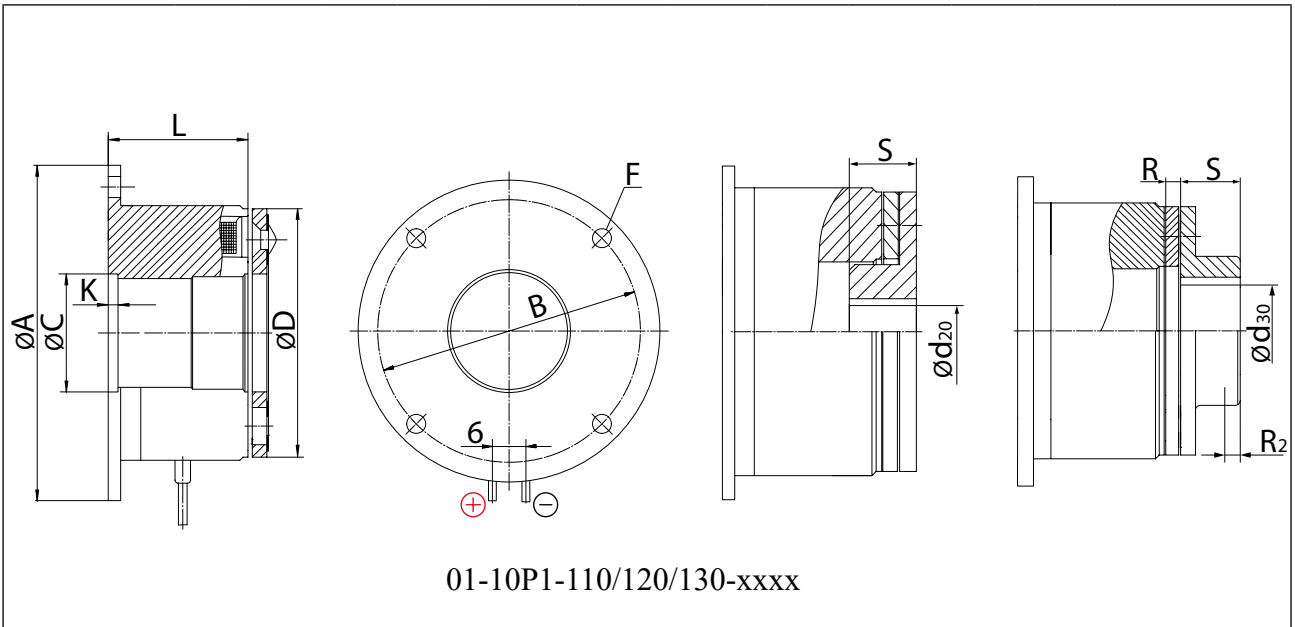

Size	Dimensions / mm												Weight / kg ..P1 110/120/130
	A	B	C	D	F	K	L	R	R ₂	S	d ₂₀	d ₃₀	
01	39	33,5	11	28	3,4	-	19,5	2,25	2,7	7	6	6	0,1
02	45	38	12,5	32	3,4	-	21,5	2,1	4	10	8	8	0,1
03	54	47	19	40	3,4	-	22,5	2,6	5	12	10	12	0,2
05	65	58	26	50	3,4	2	28,5	3	5	12	15	15	0,35
06	80	72	35	63	4,5	2	26,8	3,9	6	15	18	18	0,55
07	100	90	42	80	5,5	2	29,9	4,5	8	20	25	25	0,85
08	125	112	52	100	6,5	2,5	33,9	6,2	10	25	30	30	1,6
09	150	137	62	125	6,5	3,5	37,8	7,3	12	30	40	40	2,9
10	190	175	80	160	9	3,5	42,6	9,4	15	38	50	50	5,4

Keyway according to *DIN 6885-1* P9.

Figure 5: Dimensions COMBIPERM Type P1 Magnet with round flange

3.3.2 Magnet with square flange

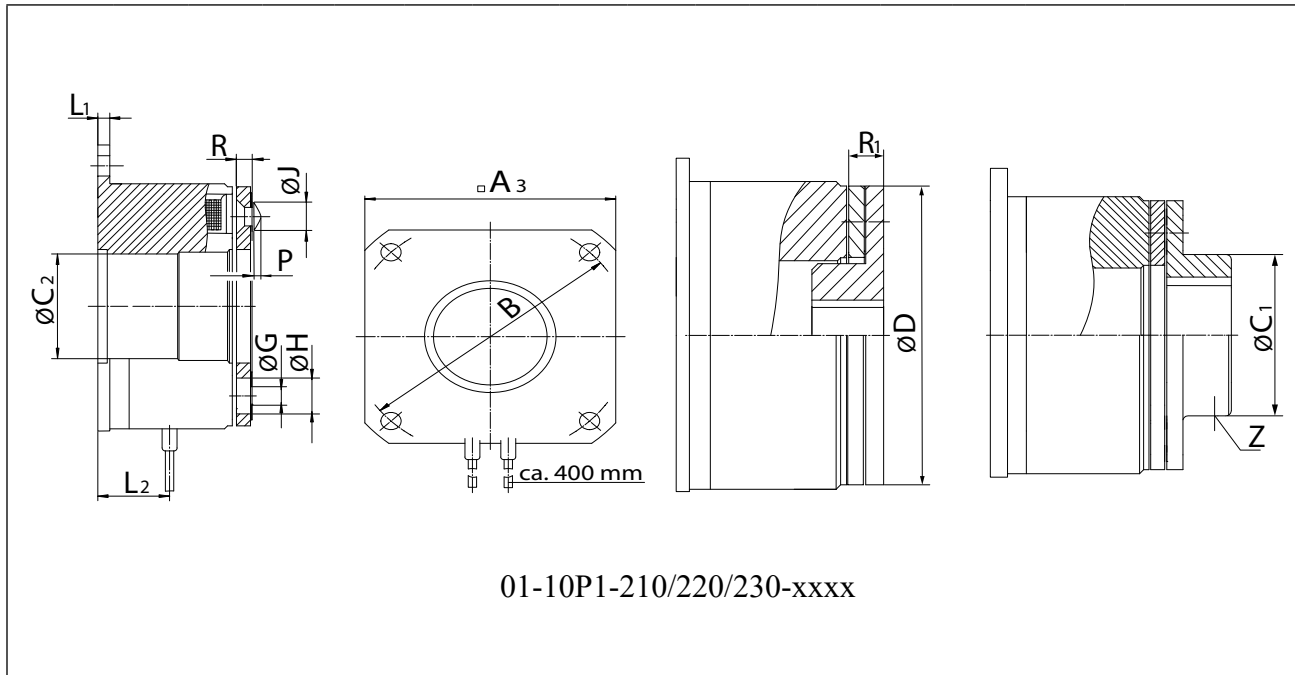

Size	Dimensions / mm														Weight / kg ..P1 210/220/230
	A ₃	B	C ₁	C ₂	D	G	H	J	L ₁	L ₂	P	R	R ₁	Z	
01	32	33,5	13,5	11	28	2x2.1	5,3	4,5	2	10,5	1	2,25	4,25	1xM3	0,1
02	34	38	16	12,5	32	3x2.6	6	5	2	10,5	1,3	2,1	4,1	1xM3	0,1
03	42	47	22	19	40	3x3.1	6	5,5	2	12	1,5	2,6	5,2	1xM4	0,2
05	53	58	24	24	50	3x3.1	6,5	5,5	2	14	1,5	3	6	1xM5	0,35
06	66	72	32	32	63	3x4.1	10	8	3	15	2	3,9	7,4	1xM6	0,55
07	83	90	38	38	80	3x4.1	11	8	3	16,5	2	4,5	8,5	1xM6	0,85
08	103	112	48	48,5	100	3x5.1	11,5	10	4	19,5	2,5	6,2	11,2	1xM8	1,6
09	128	137	57	58	125	3x6.1	15	11,5	5	23	3	7,3	13,3	2xM10	2,9
10	163	175	71	75	160	3x8.1	21	14,5	6	24	4	9,4	16,4	2xM10	5,4

Figure 6: Dimensions COMBIPERM Type P1 Magnet with square flange

3.3.3 Magnet without flange

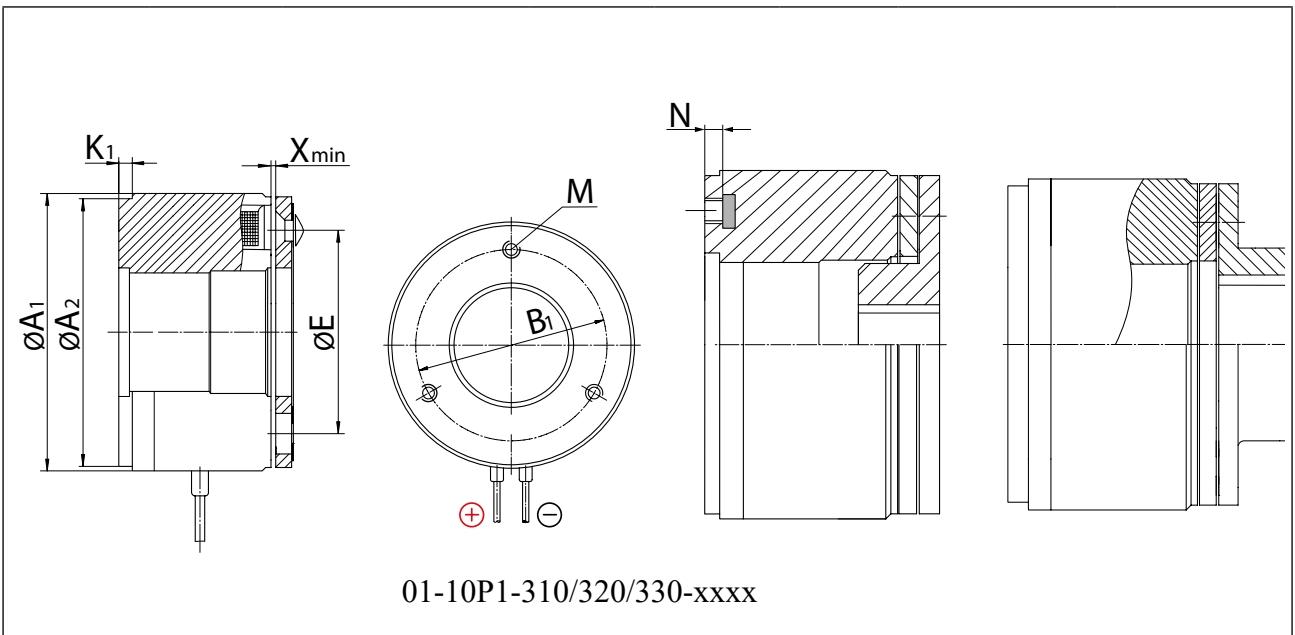

Size	Dimensions / mm								Weight / kg ..P1 310/320/330
	A ₁	A ₂	B ₁	E	K ₁	M	N	X _{min}	
01	28	28	22	19,5	3	2xM3	3	0,15	0,1
02	32,2	32	23	23	2	3xM3	3	0,15	0,1
03	41	40	28,5	30	2	3xM3	3	0,15	0,2
05	51,5	50	40	38	2	3xM3	3	0,2	0,35
06	64	63	49	50	3	3xM4	4	0,3	0,55
07	80,8	80	63	60	3	3xM4	5	0,3	0,85
08	101	100	78	76	4	3xM5	6,2	0,35	1,6
09	126	125	106	95	5	3xM6	7	0,4	2,9
10	161	160	135	120	6	3xM8	9,5	0,5	5,4

Figure 7: Dimensions COMBIPERM Type P1 Magnet without flange

4 Mounting

4.1 Notes on mounting

Inspections to be done prior to mounting the brake

Before mounting the brake, check the following:

- ▶ Compliance of the ordered voltage and performance data with the type plate data.
- ▶ No damage to the brake or contamination by foreign particles in the area of operation or in the air gap of the brake.
- ▶ The friction surfaces must be free from grease and oil.
- ▶ Air humidity, aggressive vapours/liquids or similar can lead to corrosion and 'rusting' of the pole surfaces. In this case, the user needs to provide appropriate measures!
- ▶ The brake must be energised during installation.
- ▶ Readjustment of the air gap is not possible! If necessary, check the air gap before mounting => „9.2.2 Check air gap“.

Observe during mounting

NOTICE

Risk of damage to the brake

- ▶ Mounting of the armature element is permitted only in energized condition to avoid overexpansion of the diaphragm spring at the armature element. Magnet and armature element must be centered at mounted brakes. Plan and radial run-outs cause premature failure!

During mounting, please observe the following notes/instructions:

- ▶ The friction surfaces of the brake must not come into contact with oil, grease, water or other fluids. Any contamination will result in loss of torque.
- ▶ Never use aggressive fluids (for example, cleaning agents) or the like to clean the brake.
- ▶ The movement of the armature must not be impeded by the ingress of foreign particles into the air gap. Take appropriate safety measures as required.
- ▶ The armature element of the brake is mounted on a shaft. The armature may not be centered at the in and outside diameter. It must be able to move free, because it must be placed through the riveted spring. This shaft must maintain the concentricity (to A or B) and perpendicularity (to C) listed in the table (see next page).

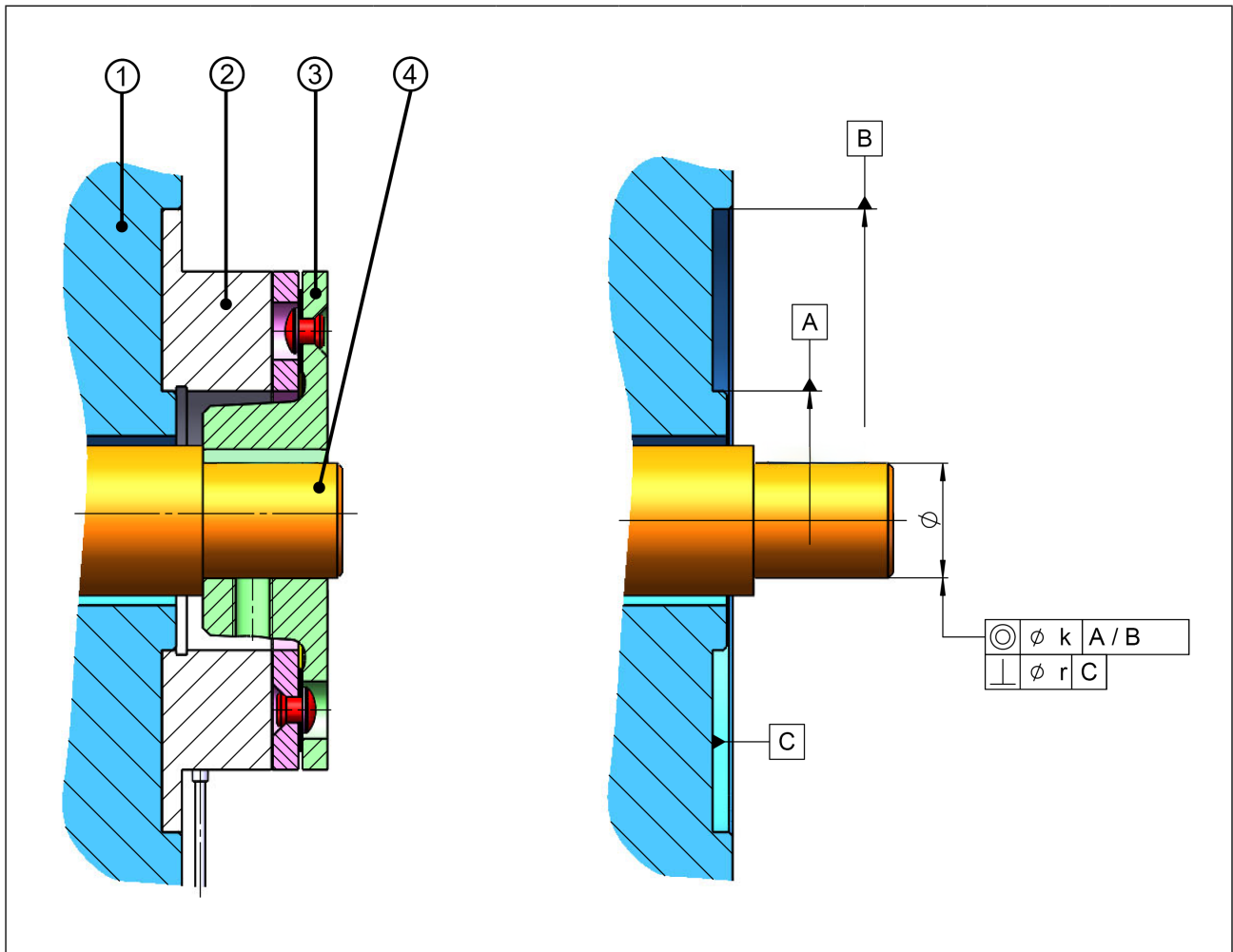

Legend

1	Customer flange								
2	Magnet								
3	Armature element								
4	Customer shaft								
Size	01	02	03	05	06	07	08	09	10
k / mm	0,1	0,1	0,1	0,1	0,2	0,2	0,2	0,2	0,3
r / mm	0,04	0,04	0,04	0,06	0,06	0,06	0,06	0,08	0,08

Figure 8: Concentricity k between magnet centering and shaft (armature bore)

4.2 Mounting the brake

4.2.1 Mounting the magnets for brakes

	<p>Outside centering (e.g. Type 110/120/130,210/220/230,310/320/330 in size 01...10)</p> <p>The magnet can be centered via the outside diameter of the magnet and screwed to the mounting surface with socket head screws (e.g. DIN 4762, 8.8). Pay attention to the screw-in depth for magnets without flange since otherwise the magnet can be damaged!</p>
	<p>Inside centering (e.g. Type 110/120/130,210/220/230,310/320/330 in size 01...10)</p> <p>The magnet can be centered via the inside diameter of the magnet and screwed to the mounting surface with socket head screws (e.g. DIN 4762, 8.8). Pay attention to the screw-in depth for magnets without flange since otherwise the magnet can be damaged!</p>
	<p>Fixing the magnet face-mounted at the magnet back (e.g. Type 310/320/330 in size 01...10)</p> <p>At versions magnet without flange (e.g. xx P1 310/320/330-xxxx), the magnet is face-mounted with the magnet back to the motor flange site with socket head screws.</p>

Figure 9: Installation of the magnets

4.2.2 Example 1: Brake without hub (e.g. 01...10P1-110/210/310-xxxx)

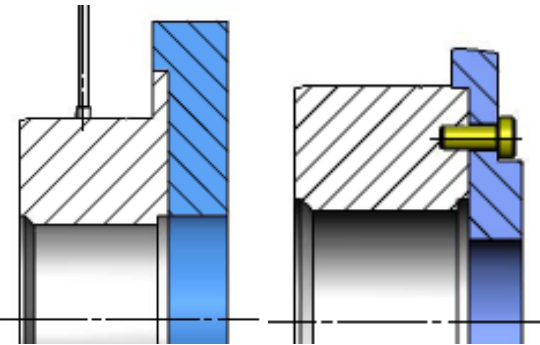
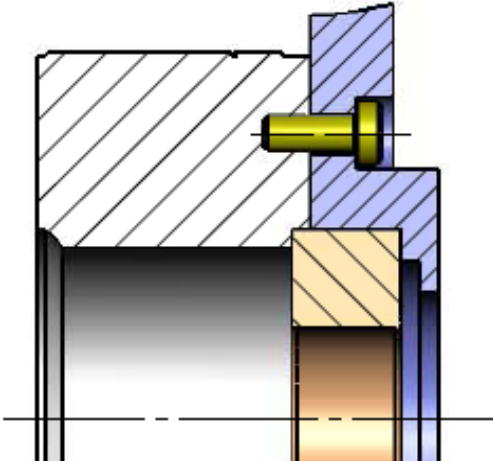
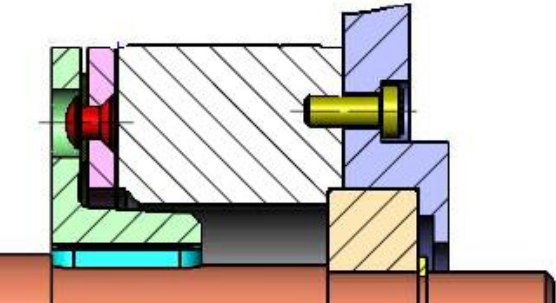
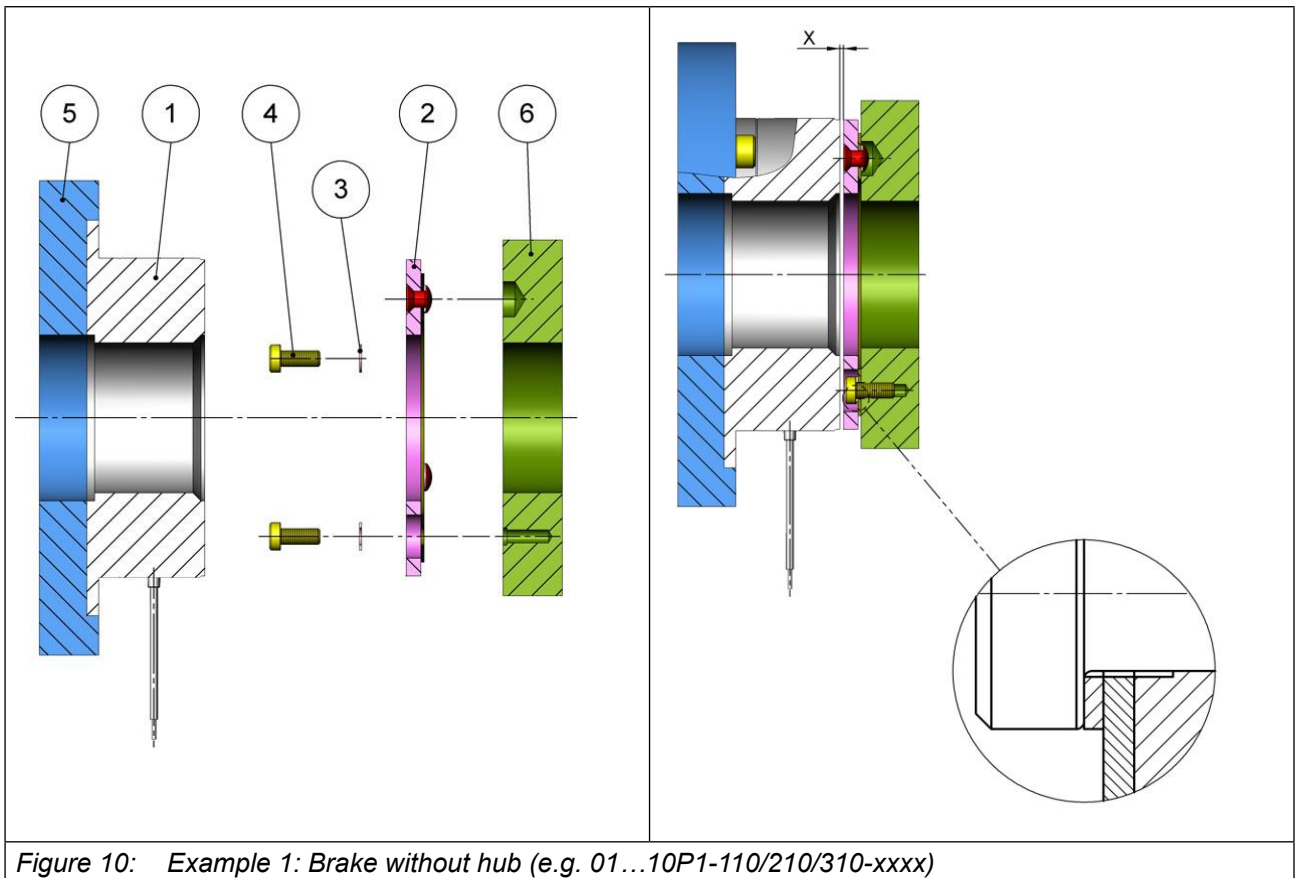

Figure 10: Example 1: Brake without hub (e.g. 01...10P1-110/210/310-xxxx)

- ▶ The shaft of the motor (see also figure 2) and the mounting surface (5) must be constructed by way, that during mounting the air gap X occurs automatically.
- ▶ If necessary, the air gap X can be adjusted with adjusting washers.
- ▶ Mount the magnet (1) with the socket head screws to the mounting surface (5).
- ▶ Place the armature element (2) to the mounting surface on customer-side (6).
- ▶ Screw the socket head screws (4) lightly with the Schnorr lock washers (3).
- ▶ Align the armature element and tighten the socket head screws.
- ▶ Mount the component (6).
- ▶ Secure the component (6) axially.
- ▶ Check the air gap X. Adjust it, if necessary.



Notes to the socket head screws!

To attach the magnetic system, we recommend using socket head screws of property class 8.8 which should be tightened with the tightening torques recommended by the manufacturer.

Check air gap X.

Further information on the air gap which becomes larger as a result of wear can be found in section => „9.2.2 Check air gap“.

4.2.3 Example 2: Brake with armature element - hub neck outside (e.g. 01...10P1-130/230/330-xxxx)

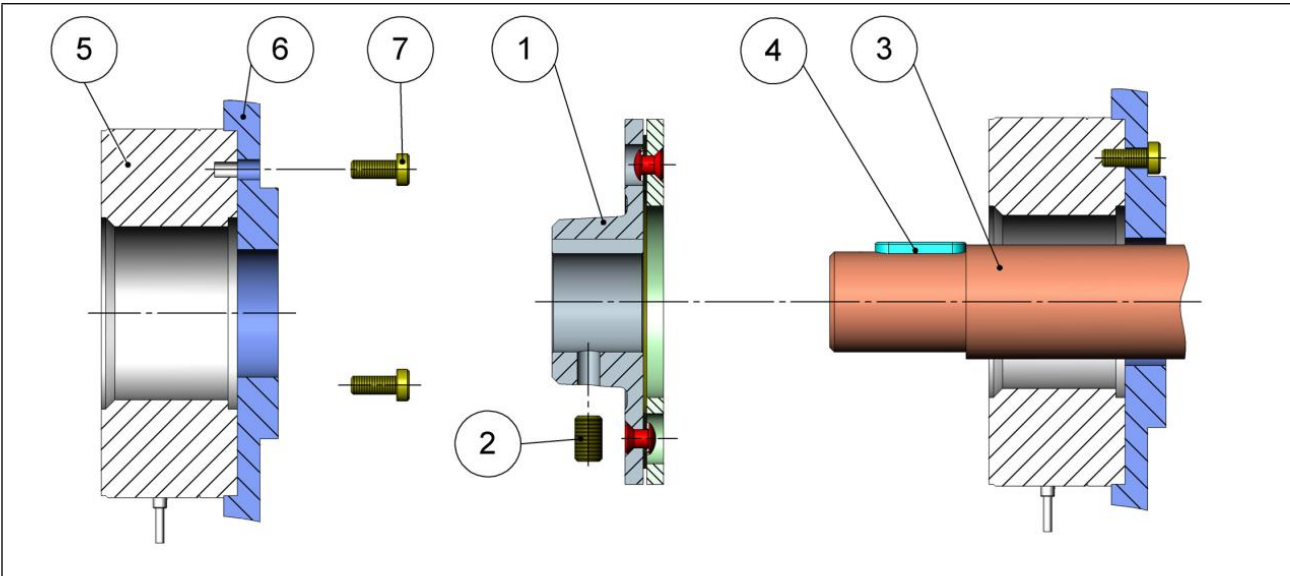
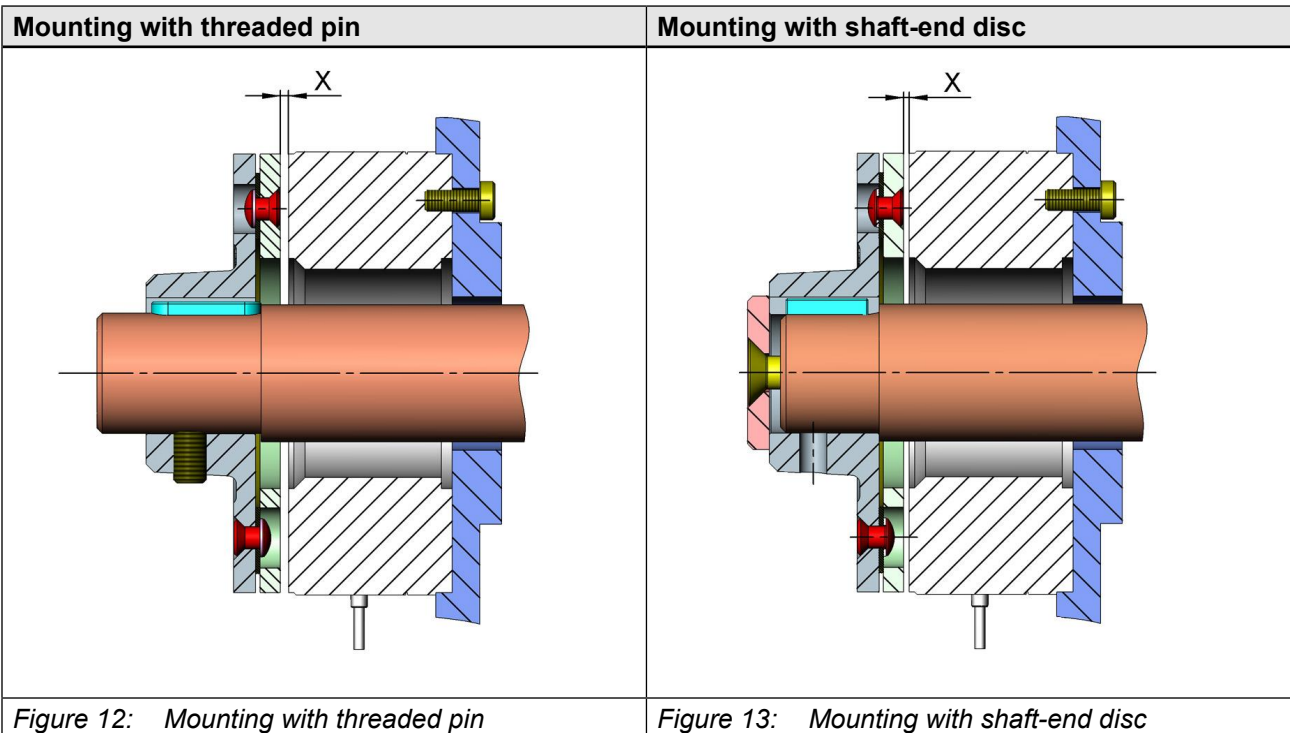

Figure 11: Example 2: Brake with armature element - hub neck outside (e.g. 01...10P1-130/230/330-xxxx)

- ▶ Mount the magnet (5) with the socket head screws (7) at the motor flange (6).
- ▶ Push the armature element (1) onto the motor shaft (3) with mounted feather key (4).
- ▶ Secure the armature element (1) with a shaft-end disc or retaining ring or with a mounted threaded pin (2) axially onto the motor shaft (3).



Check air gap X.

Further information on the air gap which becomes larger as a result of wear can be found in section => „9.2.2 Check air gap“.

4.2.4 Example 3: Brake with armature element – hub neck inside (e.g. 01...10P1-120/220/320-xxxx)

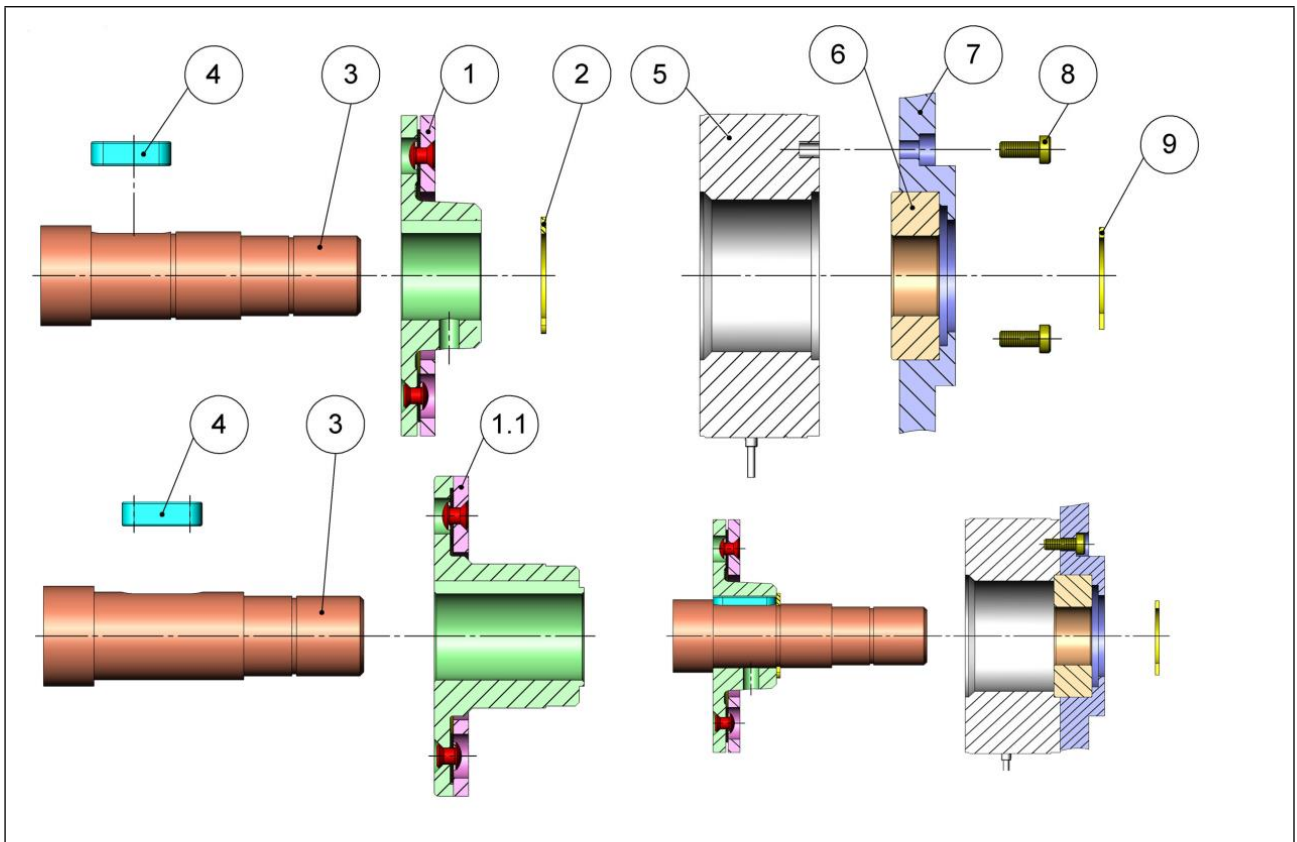

Figure 14: Example 3: Brake with armature element – hub neck inside (e.g. 01...10P1-120/220/320-xxxx)

- ▶ Push the armature element with hub neck inside, short type (1) onto the motor shaft (3) with mounted feather key (4).
- ▶ Secure the armature element (1) with a retaining ring (2) axially onto the motor shaft (3).
- ▶ Mount the magnet (5) with the socket head screws (8) at the motor flange (7). To this end, refer to section "4.2. Mounting the magnets for brakes". Tighten the socket head screws with the recommended tightening torque.
- ▶ If an armature element with hub neck inside, long type (1.1) is used, the hub is propped on the inner ring of the motor ball bearing (6). The air gap X must occur automatically by design, if necessary it can be adjusted with adjusting washer between armature element (1.1) and bearing / shaft (6 / 3).

Brake with armature element hub neck inside, short type

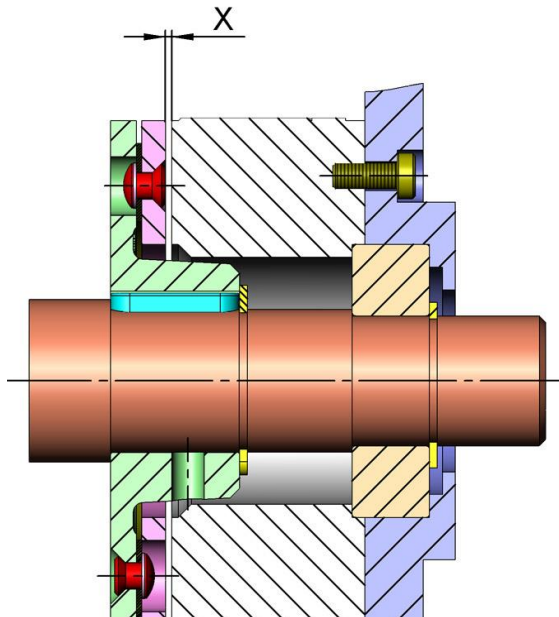

Figure 15: Brake with armature element hub neck inside, short type

Brake with armature element hub neck inside, long type

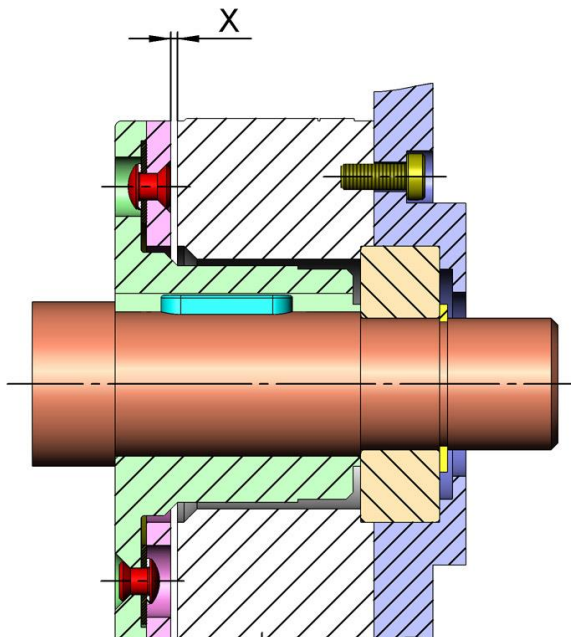

Figure 16: Brake with armature element hub neck inside, long type

Check air gap X.

Further information on the air gap which becomes larger as a result of wear can be found in section => „9.2.2 Check air gap“.

5 Electrical connection

⚠ DANGER



Electrical voltage at the motor!

Danger to life due to electric shock!

- ▶ When carrying out any work on the brake, switch off the supply voltage to the motor and secure it against switching on.

NOTICE

Voltage peaks when switching off!

- ▶ Install protective circuit for brake and control.
- ▶ The protective circuit leads to longer connection times.

NOTICE

Destruction of the brake in case of incorrect voltage supply!

- ▶ The brake is operated with DC voltage (operation with rated voltage +6%/-10%).
- ▶ Read the rated voltage from the nameplate of the brake.
- ▶ Compare with existing voltage source.
- ▶ The maximum input voltage U_{in} must not be exceeded.
- ▶ Only connect if the values match.



When using rectifiers, the use of bridge rectifiers is recommended.

The brake COMBIPERM Type P1 is delivered with factory-preassembled connecting cables:

COMBIPERM P1	01	02...06	07...10
Connection cross section	AWG22	AWG20	AWG18
Connection length	400 mm		

Table 6: Connecting the brake



Influence of rectifiers on the connection time!

The brake can be switched off on the DC or AC side when voltage is supplied via a rectifier. Switching off on the DC side reduces the connection time, i.e. the period of time until the torque is reached to decelerate.

6 Start-up

6.1 Inspections prior to start-up of the brake

Visual inspection

- Do connection and rated voltage (nameplate) agree?
- Are external damages visible?
- Are there impurities in the functional area or foreign bodies in the air gap of the brake?

Load-free testing

- Ensure that the brake is unloaded.
- Release/close the brake by switching the voltage supply.

NOTICE

Damage due to non-observance!

- ▶ Do not start up if one of the checks is not OK.

6.1.1 Run in of the brake

NOTICE

Damage due to insufficient braking torque!

- ▶ The braking torque is only reached after the brake has run in.

As standard, brakes are brought to braking torque after installation by initial running-in. If special agreements have been made, the initial run-in has already taken place at KEB. In this case, only an adjustment run with reduced circuits is required.

Device size	01	02	03	05	06	07	08	09	10
Slip time <i>t</i> / s	2	1							0,5
Idle time <i>t</i> / s	0,5								
Speed <i>n</i> / rpm	250	300	200	100			50	25	
Circuits first running-in	50			30	25		30	40	
Circuits adjustment running-in	10				5		6	8	

Table 7: Run in of the brake

Notes on running-in process:

- Energise the magnet.
- Rotate the drive/motor with the speed from => „[Table 7: Run in of the brake](#)“.
- Do not energise the magnet.
- Let the brake slip according to the slip time from => „[Table 7: Run in of the brake](#)“.
- Energise the brake according to the idle time from => „[Table 7: Run in of the brake](#)“.
- Repeat the circuits according to the initial or adjustment run from => „[Table 7: Run in of the brake](#)“.
- Stop the drive/motor.
- Check the torque.
- If the torque is not reached, repeat the process.

NOTICE**Damage due to loss of braking torque!**

If the brake is only used as a holding brake without dynamic load, the braking torque may drop. A new running-in (refreshment) must be done within the scope of maintenance => „[9.2.4 Maintenance running-in of the brake](#)“.

7 Operation

The brake is only electrically controlled.
There are no manual operating options.

8 Troubleshooting

The following table shows some causes and solutions of malfunctions during brake operation. If this does not solve the problem or if other malfunctions occur, please contact our service department.

Malfunction	Cause	Measures
Brake does not release	Incorrect voltage	Only operate the brake with the correct voltage (see nameplate of the brake).
	Rectifier failed	Replace the rectifier.
	Foreign particles between armature and lining	Remove the foreign particles. Use non-greasing cleaning agents to clean the brake.
	Magnet coil or connecting cable defective	Replace the brake.
	Excessive heating	Install a high-speed circuit breaker (for example, KEB Powerbox).
No braking function	Air gap too large, maximum air gap reached	Replace the brake.
	Friction surfaces contaminated	Clean the friction surfaces, replace if necessary.
Brake operates with delay, long connection time	Brake is switched on AC side	Switch the brake on the DC side.
<i>Table 8: Troubleshooting</i>		

9 Maintenance and service

- Observe the general safety instructions.
- The brake must not be under voltage during maintenance and repair work!
- Protect electrical and electronic components from splash water.

9.1 Maintenance intervals

The brake COMBIPERM type P1 is mainly maintenance-free. As a result of wear occurring during operation, the air gap increases. The function of the brake can only be ensured when the air gap X is checked at regular intervals.

9.2 Service

Service is required if, in accordance with the fault table, there are symptoms of damaged or soiled coverings, unusual noises or smells.

⚠ CAUTION

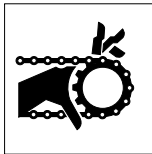

Limbs crushed!

Securing the load!

- ▶ Mechanically secure the load against unintended movement.
- ▶ Release brake from load.
- ▶ Dismounting of the brake according to manual.

9.2.1 Dismount the brake

- ▶ The dismounting is carried out under voltage supply
- ▶ Remove the armature element from the shaft (to this end, refer to the instruction manual of the motor).
- ▶ Remove the three socket screws.
- ▶ Remove the brake from the end shield.

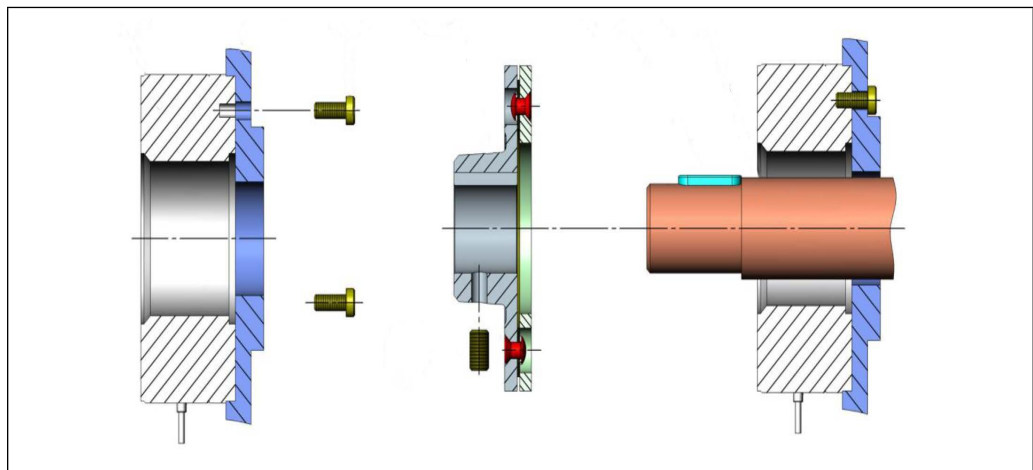

Figure 17: Dismount the brake

9.2.2 Check air gap

As a result of wear occurring during operation, the air gap increases. To ensure proper functioning, the air gap X needs to be checked at regular intervals. When checking the air gap pay attention that parallelism and axial run-out tolerances must be added to the rated air gap X.

Size	Air gap	
	Rated value X	Limit value X _{max} ¹⁾
	mm	mm
01	0,15	0,3
02	0,15	0,3
03	0,15	0,4
05	0,2	0,5
06	0,3	0,65
07	0,3	0,8
08	0,35	0,8
09	0,4	1,0
10	0,5	1,2

Table 9: Check air gap

¹⁾ The air gap where replacement is recommended.

9.2.2.1 Checking the air gap X

- ▶ Use a feeler gauge (F) to check the air gap X.
- ▶ The brake must be replaced if the air gap X is greater than X_{max} .

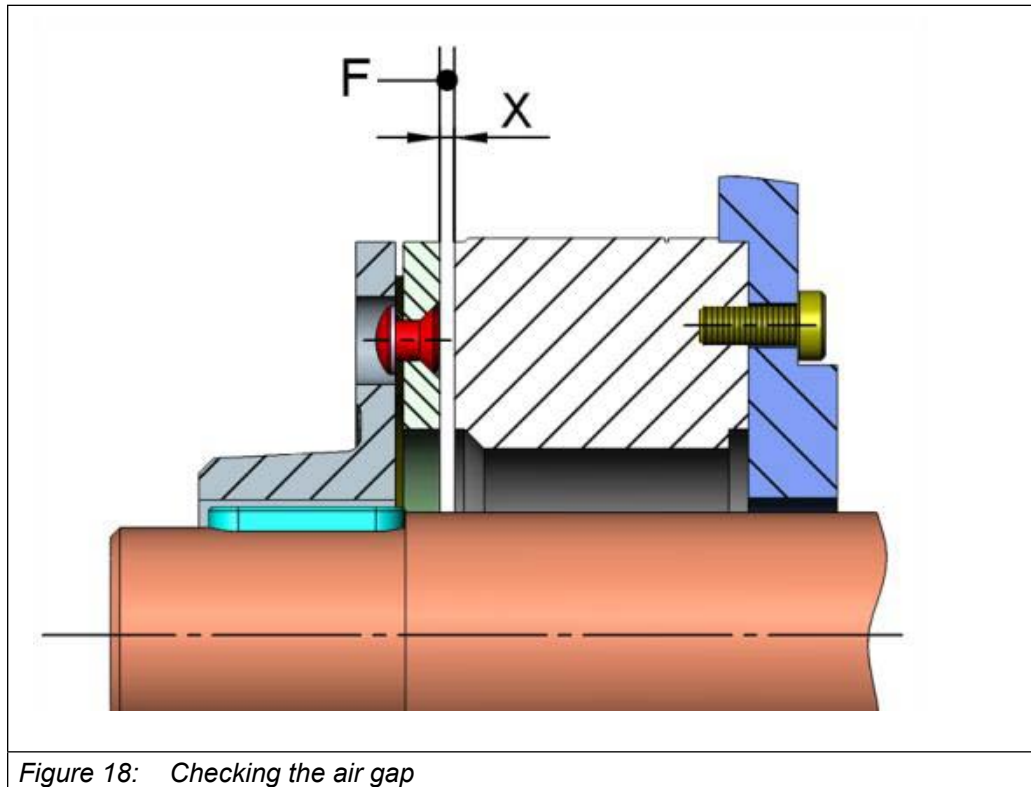

Figure 18: Checking the air gap

9.2.3 Exchange the brake

- ▶ On exchange the brake with armature element must be completely replaced.
- ▶ Disconnect the connecting cable(s) from the voltage supply.
- ▶ Dismount the brake (=> "9.2.1 Dismount the brake").
- ▶ The brake is mounted in reverse order of mounting (=> "9.2.1 Dismount the brake").
- ▶ Functional test and start-up (=> "9 Maintenance and service").

9.2.4 Maintenance running-in of the brake

NOTICE

Damage due to loss of braking torque!

If the brake is only used as a holding brake without dynamic load, the braking torque may drop. A new run in (refreshment) must be done within the scope of maintenance.

A maintenance interval of 4 weeks is recommended for normal industrial applications.

Device size	01	02	03	05	06	07	08	09	10
Slip time <i>t</i> / s	0,5								
Idle time <i>t</i> / s	0,5								
Speed <i>n</i> / rpm	250	200	100	75	50	25	15		
Circuits	5						3		
<i>Table 10: Maintenance running-in (Refreshment)</i>									

10 Disassembly and disposal

10.1 Disassembly

To disassemble the brake => „9.2.1 Dismount the brake“.

10.2 Disposal



Separated according to the materials used, dispose of the electromagnetic brake components in compliance with the applicable local environmental regulations.

The corresponding key numbers are subject to change depending on the disassembling process (metals, plastics and cables).

The components can be disposed of as follows:

Magnet with coil, cables and all other steel parts:

Steel scrap (Key No.: EAK 12 01 02)

Aluminium components:

Nonferrous metals (this includes copper) (Key No.: EAK 16 01 18)

11 Certification

11.1 EU declaration of conformity

A declaration of conformity is not required for COMBIPERM.



Certificate: 70199031

Master Contract: 172220

Project: 70199031

Date Issued: 2018-10-05

Notes:

1. The first two figures define the size of the product. The next two figures describe the product type, e.g. COMBISTOP. The following three figures describe the design and the last four figures describe the layout of the product type.
2. Component magnets equipped with not certified leads are supplied with levels acceptable for extra low Voltage, energy limited circuits only. Final acceptability is subjected to re-evaluation by CSA in the end use.

APPLICABLE REQUIREMENTS

CSA-C22.2 No. 14-18 - Industrial Control Equipment

ANSI/UL 508, Ed.17 - Industrial Control Equipment



Supplement to Certificate of Compliance

Certificate: 1267150 (LR49670)

Master Contract: 172220 (049670_0_000)

The products listed, including the latest revision described below, are eligible to be marked in accordance with the referenced Certificate.

Product Certification History

Project	Date	Description
70199031	2018-10-05	Update of report to cover correction of issued address and to update report in accordance with CSA-C22.2 No. 14-18 and Certification notice Industrial Control Equipment No. 60 , dated at April 26, 2018.
1817504	2006-08-25	Alternate construction and re-testing of brakes and clutches, series Combistop, Combiperm and Combinom. Rated voltage raised to 205 Vdc for Combiperm and Combinom.
1267150	2002-04-08	cCSAus Certification on Electromagnetic brakes and clutches; COMBISTOP, Types 08, 28, 31, 38, 71; COMBIPERM, Types P1, 15; COMBINORM, Types 02, 03, 04.

Figure 19: CSA Certificat

12 Revision history

Version	Date	Description
00	2011-09	First edition
01	2020-05	Complete editorial revision
02	2020-07	Chapter 3.2.1 Operating speed renamed to braking speed
03	2021-03	Chap. 3.2.1 Technical data adapted
04	2024-01	Change of cover picture, content adjustments
05	2025-04	Adaptation of technical data
06	2025-04	Chap. 3.3.2 Technical data adapted



MORE KEB PARTNERS WORLDWIDE:

www.keb-automation.com/contact



Automation with Drive

www.keb-automation.com

KEB Automation KG Suedstrasse 38 D-32683 Barntrop Tel. +49 5263 401-0 E-Mail: info@keb.de