

**KEB**



# **BRAKES & CLUTCHES**

PRODUCT PORTFOLIO MAGNET TECHNOLOGY

**EN**

**Proven standard** version  
or individually adapted to the  
customer's requirements

The KEB logo is a red square with the letters 'KEB' in white, bold, sans-serif font. It is positioned in the lower-left area of the image, partially overlapping the rows of motor components.

**KEB**

## RELIABLE BRAKES AND CLUTCHES FOR YOUR DRIVE

KEB's success story began over 50 years ago in the field of brakes and clutches, and the safety and reliability of our products have been impressing customers around the world ever since.

In addition to our standard range of safety brakes, safety clutches and corresponding electronic accessories, we work with you to adapt the products to your requirements and needs.

In the process, we manufacture the products in accordance with the valid ISO 9001 quality guidelines and, for our automotive customers, also in accordance with IATF 16949.

### IIoT



### CONTROL HARDWARE

Visualisation



HMI

Engineering



Control Software

Remote Control



Router

### CONTROL HARDWARE



Web HMI



Embedded Control

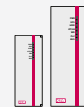

IPC



I/O



Safety PLC

### DRIVES



Inverter



Servo Drive



Drive Controller



Pitch Drive

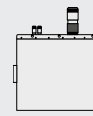

eMobility Drive

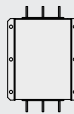

EMC & THD Filter

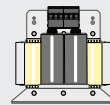

Sine Wave Filter

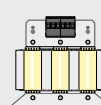

Motor Choke

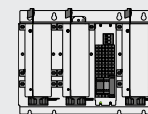

Sine Wave EMC Filter

### MOTORS



AC Motor



PM Motor



PM Gear Motor



AC Gear Motor

### BRAKES AND CLUTCHES



Permanent Magnet Brake



Spring Applied Brake



Electromagnetic Brake



Electromagnetic Clutch

# PRODUCT OVERVIEW

## SPRING-APPLIED BRAKES (Power-off safety brakes)



**COMBISTOP 08**  
**Mini brake 0.3 - 2 Nm**  
For dynamic and static applications

from page 6



**COMBISTOP 28**  
**Sealed brake (IP66) 3 - 2,000 Nm**  
For dynamic and static applications with enhanced sealing requirements or tough ambient conditions

from page 8



**COMBISTOP 38**  
**Standard spring-applied brake with modular system 3 – 2,000 Nm**  
For dynamic and static applications with varied standard options

from page 10



**COMBISTOP 38D**  
**Redundant double brake 2x3 – 2x2,000 Nm**  
For dynamic and static applications with the requirement of redundancy respectively double safety

from page 12

NEW



**COMBISTOP S1**  
**High performance holding brake 0.5 – 60 Nm**  
Holding brake with emergency stop function especially for servo applications

from page 14

NEW

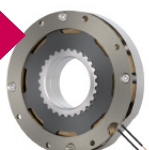

**COMBISTOP S1 FLAT**  
**Holding Brake in flat design 3,4 – 10,8 Nm**  
Holding brake S1 with patented friction system

from page 16

## PERMANENT MAGNET BRAKES AND CLUTCHES (Power-off brakes and clutches)



### COMBIPERM P1

**Standard permanent magnet brake 0.15 – 194 Nm**

Backlash-free brake for static applications with emergency stop function

from page 20

**NEW**

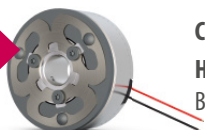

### COMBIPERM P2

**High performance permanent magnet brake 3 – 75 Nm**

Backlash-free brake with improved emergency stop function and temperatures up to -40°C

from page 22



### COMBIPERM PC

**permanent magnet clutch 1.5 – 120 Nm**

Safety clutch: In case of an emergency the drive and output are coupled

from page 24

## ELEKTROMAGNETIC BRAKES AND CLUTCHES (Power-on brakes and clutches)



### COMBINORM B

**Electromagnetic brake 0.5 – 1,250 Nm**

For precise positioning and reliable holding

from page 26



### COMBINORM C

**Electromagnetic clutch 0.5 – 1,250 Nm**

For simple controlled switching on and off of functional parts in synchronised processes

from page 28



### COMBINORM T

**Electromagnetic tooth clutch 31 – 390 Nm**

For torsional backlash-free and positive transmission of torque

from page 34

## ACCESSORIES AND TOOLS



### COMBITRON 91

**Rectifier up to 720V**

from page 36



### COMBITRON 98

**POWERBOX ECO / fast-acting rectifier up to 94% energy saving**

from page 37

## CUSTOMIZED SOLUTIONS

Individual designs and customized development, testing and production from a single source

from page 38

## COMBISTOP 08 - MINI BRAKE

The COMBISTOP 08 is KEB's mini-series of closed-current spring-applied brakes. This brake solution is characterised by a particularly compact construction, and is designed for small loads.

The 08 can be used as a service brake for dynamic applications, and as a holding brake with an emergency stop function for static applications.

### OPTIONS:

- Manual release
- Flange
- Sealing plug
- CCV - Cold Climate Version down to 40 °C
- Modified braking torque
- Customized voltages
- Connector assembly
- Certificate 2.1 / acceptance test certificate 3.1



**AREAS OF APPLICATION:** SERVO MOTORS | MEDICAL TECHNOLOGY | ROBOTICS AND AUTOMATION | INDUSTRIAL TRUCKS & AGVS  
MATERIAL HANDLING | DOOR AND GATE OPERATORS | E-MOBILITY

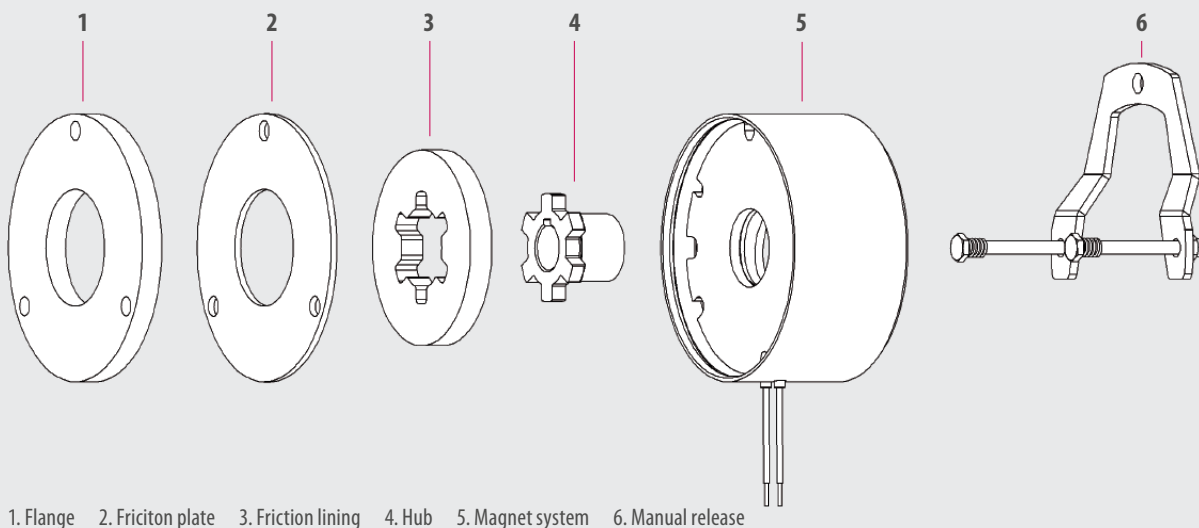

1. Flange 2. Friction plate 3. Friction lining 4. Hub 5. Magnet system 6. Manual release



### HIGHLIGHTS

- Two sizes
- Ready to install, adjusted air gap
- Used as a service brake or holding brake
- Iso class B in accordance with VDE 0580
- CSA/CUS-certified
- Designed for S1 operation or 100 % duty cycle
- Standard voltages 24 / 105 / 180 / 205V

SIZE	Reduced torque [Nm]	Rated torque $M_z$ [Nm]	Increased torque* [Nm]	Standard power P [W]	D [mm]	H [mm]	M [mm]	L [mm]	$L_2$ [mm]	$d_{max}$ [mm]
0B	-	0.3	-	6	40	-	34	23	-	8
00	0.5	1	2	11 - 15	59.5	41	52	29.5	39.7	10

Rated torque is reached after pairing conditioning of the friction partners

\*Holding brake with emergency stop function

Assembly situation	Without options	With shaft sealing ring* or sealing plug	Customized solution
Uncovered machine side	IP11	IP55	on request
Under the fan cowl without manual release	IP54	IP55	on request
Under the fan cowl with manual release	IP22	IP55	on request

\*The protection class of the shaft sealing ring depends on the respective of the manufacturer

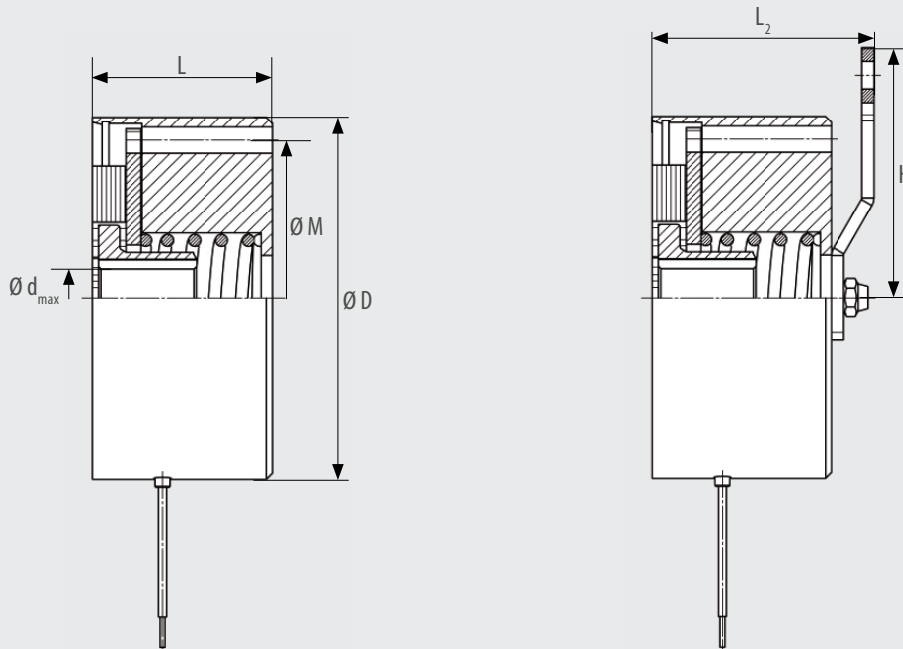

Download 3D models here and view further technical data

## COMBISTOP 28 – SEALED BRAKE

The brake can be used as a service brake for dynamic applications, and as a holding brake with an emergency stop function for static applications. Thanks to its modular system, the COMBISTOP can be easily assembled according to individual requirements.

Even project solutions for implementing specific requirements that go beyond the standard can be achieved thanks to our in-house development and production.

### OPTIONS:

- Manual release
- Microswitch to monitor performance or wear and tear\*
- Flange / centering flange
- Shaft sealing ring / sealing plug
- CCV - Cold Climate Version down to 40 °C
- Threaded holes on the back for encoder attachment
- Modified braking torque
- Flat design
- Customized voltages
- Connector assembly
- Certificate 2.1 / acceptance test certificate 3.1
- Corrosion protection class up to C4

\* From size 03 upwards



**AREAS OF APPLICATION:** CRANES AND HOISTS | MEDICAL TECHNOLOGY | WIND ENERGY | INDUSTRIAL TRUCKS & AGVS  
MATERIAL HANDLING | AGRICULTURE | MINING AND MUNICIPAL MACHINERY

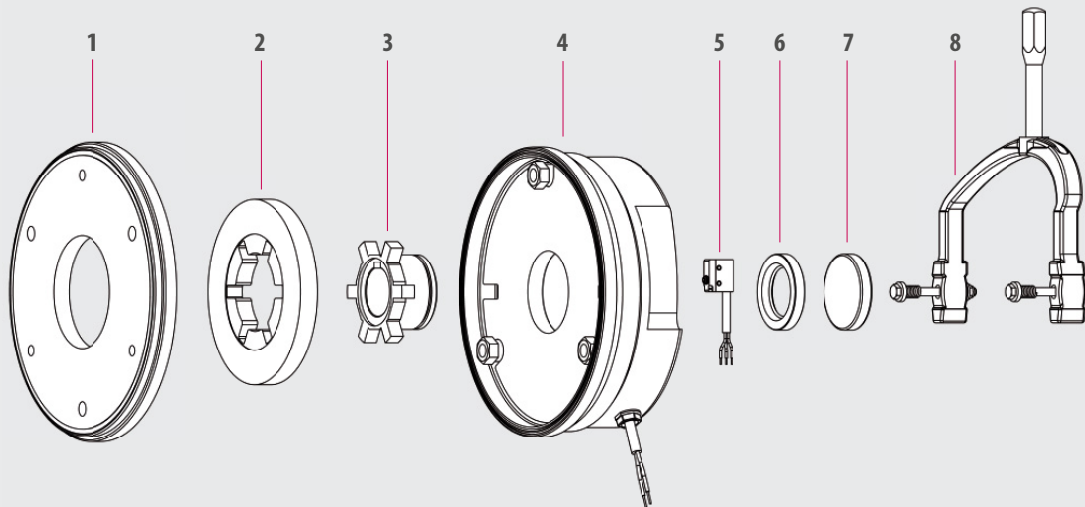

1. Flange 2. Friction lining 3. Hub 4. Magnet system 5. Micro switch 6. Shaft sealing ring 7. Sealing plug 8. Manual release



### HIGHLIGHTS

- Ten sizes
- Ready to install, adjusted air gap
- Used as a service brake or holding brake
- Up to Iso class H in accordance with VDE 0580
- CSA / CUS-certified
- Protection class up to IP67
- Designed for S1 operation or 100 % duty cycle
- Up to 7 million switching cycles as standard
- Standard voltages 24 / 105 / 180 / 205V

SIZE	Reduced torque [Nm]	Rated torque $M_2$ [Nm]	Increased torque* [Nm]	Standard power P [W]	D [mm]	H [mm]	M [mm]	L [mm]	$d_{max}$ [mm]
02	3	6.5	10	25	98	105.5	72	39	15
03	4	13	20	30	118	114	90	42.8	20
04	8	25	40	30	143	128	112	52.8	25
05	15	45	65	48	165	166	132	58.3	30
06	33	90	120	62	180	176	145	68.8	35
07	65	130	200	65	210	225	170	74.2	45
08	75	200	300	75	240	235	196	86.5	60
09	120	330	500	80	276	256	230	102	60
10**	165	665	1000	130	328	335	278	118	75
11**	445	1335	2000	180	on request		325	on request	

Braking torque tolerance  $\pm 25\%$  after pairing conditioning of the friction partners \*Holding brake with emergency stop function \*\*Quantity dependent project solution

Assembly situation	Without options	Customized solution
Uncovered machine side without manual release	IP66	up to IP67
Uncovered machine side with manual release	IP65	up to IP67
Under the fan cowl without manual release	IP66	up to IP67
Under the fan cowl with manual release	IP66	up to IP67

\*The protection class of the shaft sealing ring depends on the respective of the manufacturer

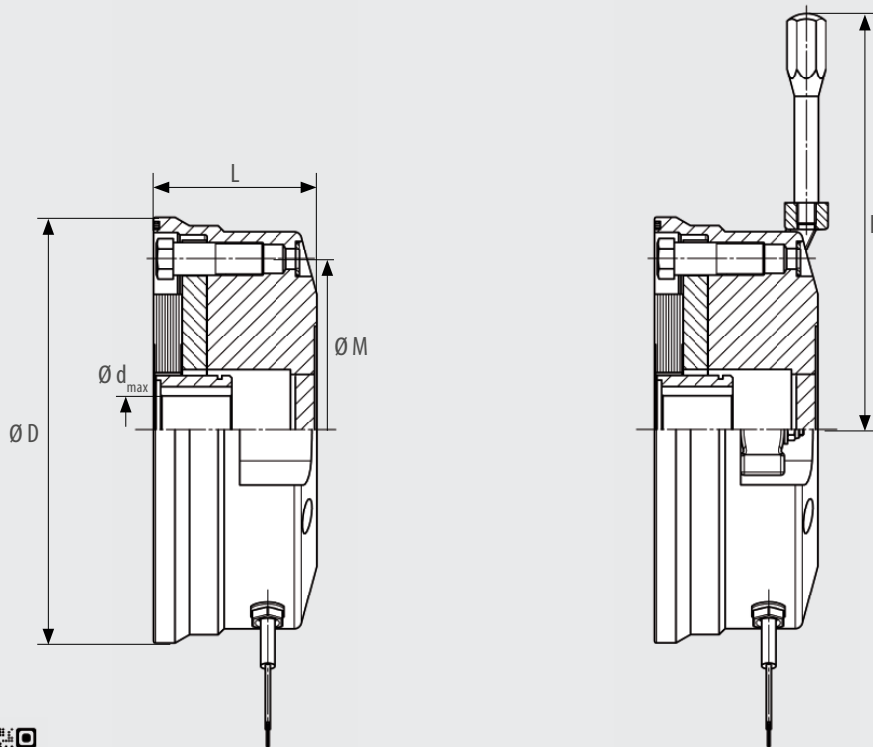

Download 3D models here and view further technical data

## COMBISTOP 38 – STANDARD SPRING-APPLIED BRAKE

The brake can be used both as a service brake for dynamic applications, and as a holding brake with an emergency stop function for static applications. Thanks to its modular system, the COMBISTOP can be easily assembled according to individual requirements in terms of braking torque and varied options.

Even project solutions for implementing specific requirements that go beyond the standard can be achieved thanks to our in-house development and production.

### OPTIONS:

- Manual release
- Microswitch to monitor performance or wear and tear\*
- Flange / friction disc
- Dust protection ring
- Shaft sealing ring / sealing plug
- CCV - Cold Climate Version down to 40 °C
- Threaded holes on the back for encoder attachment
- Modified braking torque
- Flat design
- Customized voltages
- Connector assembly
- Certificate 2.1 / acceptance test certificate 3.1

\* From size 03 upwards



**AREAS OF APPLICATION:** MATERIAL HANDLING | WIND ENERGY | MEDICAL TECHNOLOGY | ROBOTIC AND AUTOMATION  
INDUSTRIAL TRUCKS & AGVS | CRANES AND HOISTS

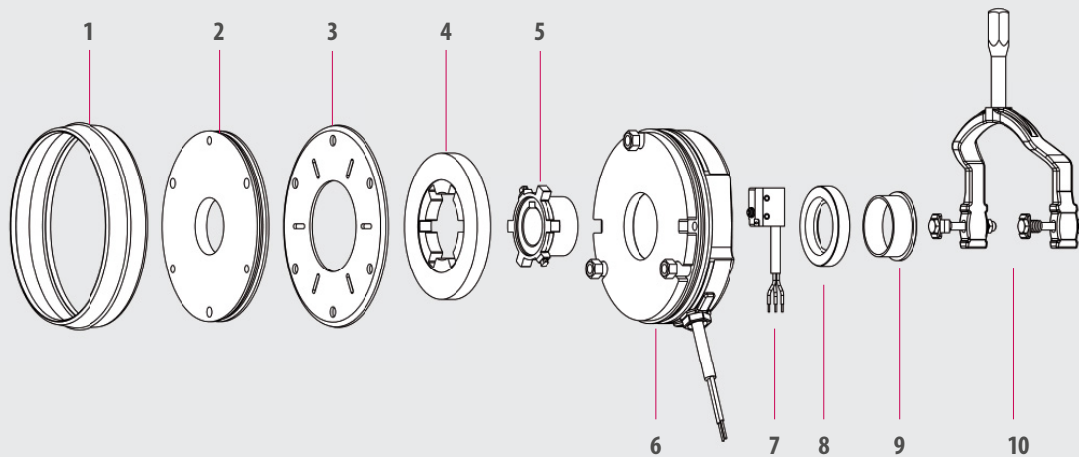

1. Dust protection ring 2. Flange 3. Friction disc 4. Friction lining 5. Hub 6. Magnet system  
7. Micro switch 8. Shaft sealing ring 9. Sealing plug 10. Manual release



### HIGHLIGHTS

- Ten sizes
- Ready to install, adjusted air gap
- Used as a service brake or holding brake
- Up to Iso class H in accordance with VDE 0580
- CSA/CUS-certified
- Protection class up to IP54
- Designed for S1 operation or 100 % duty cycle
- Up to 7 million switching cycles as standard
- Standard voltages 24 / 105 / 180 / 205V

SIZE	Reduced torque [Nm]	Rated torque $M_2$ [Nm]	Increased torque* [Nm]	Standard power P [W]	D [mm]	H [mm]	M [mm]	L [mm]	$d_{max}$ [mm]
02	3	6.5	10	25	85	105.5	72	37.7	15
03	4	13	20	30	102	114	90	41.7	20
04	8	25	40	30	127	128	112	51.7	25
05	15	45	65	48	147	166	132	57.7	30
06	33	90	120	62	164	176	145	68.8	35
07	65	130	200	65	190	225	170	75.5	45
08	75	200	300	75	218	235	196	87.4	60
09	120	330	500	80	253	256	230	101.7	60
10	165	665	1000	130	307	335	278	110.8	75
11	445	1335	2000	180	363	on request	325	134.5	90

Braking torque tolerance  $\pm 25\%$  after pairing conditioning of the friction partners

\*Holding brake with emergency stop function

Assembly situation	Without options	With dust protection ring and shaft sealing ring* or sealing plug
Uncovered machine side	IP00	IP54
Under the fan cowl without manual release	IP54	IP55
Under the fan cowl with manual release	IP22	IP55

\*The protection class of the shaft sealing ring depends on the respective of the manufacturer

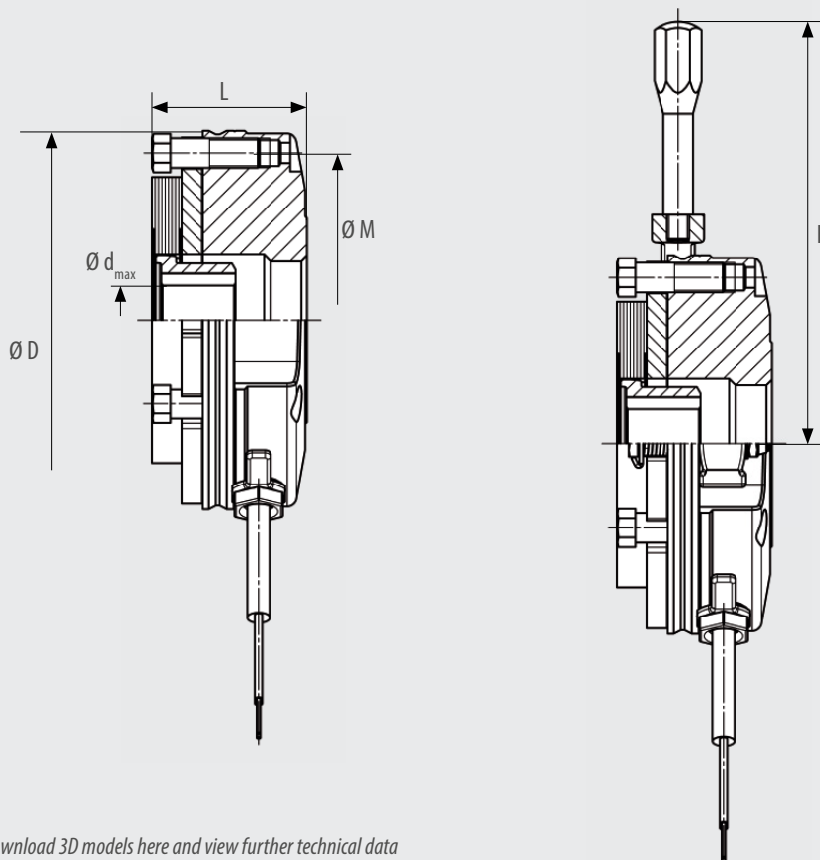

Download 3D models here and view further technical data

# COMBISTOP 38D – REDUNDANT DOUBLE BRAKE

The 38D double brake doubles the safety level and covers a range that is prepared for tasks with redundant brake circuits.

The mechanical design with two safety spring-applied brakes, which are completely independent of each other, meets the requirements according to DIN 56950 (BGV C1). The redundant brake system is delivered ready for use and adjusted by KEB.

## OPTIONS:

- Manual release
- Microswitch to monitor performance or wear and tear
- Flange / friction disc
- Dust protection ring
- Shaft sealing ring / sealing plug
- CCV - Cold Climate Version down to 40 °C
- Threaded holes on the back for encoder attachment
- Modified braking torque
- Flat design
- Customized voltages
- Connector assembly
- Certificate 2.1 / acceptance test certificate 3.1



**AREAS OF APPLICATION:** MEDICAL TECHNOLOGY | CRANES AND HOISTS | MATERIAL HANDLING  
AGRICULTURE | MINING AND MUNICIPAL MACHINERY

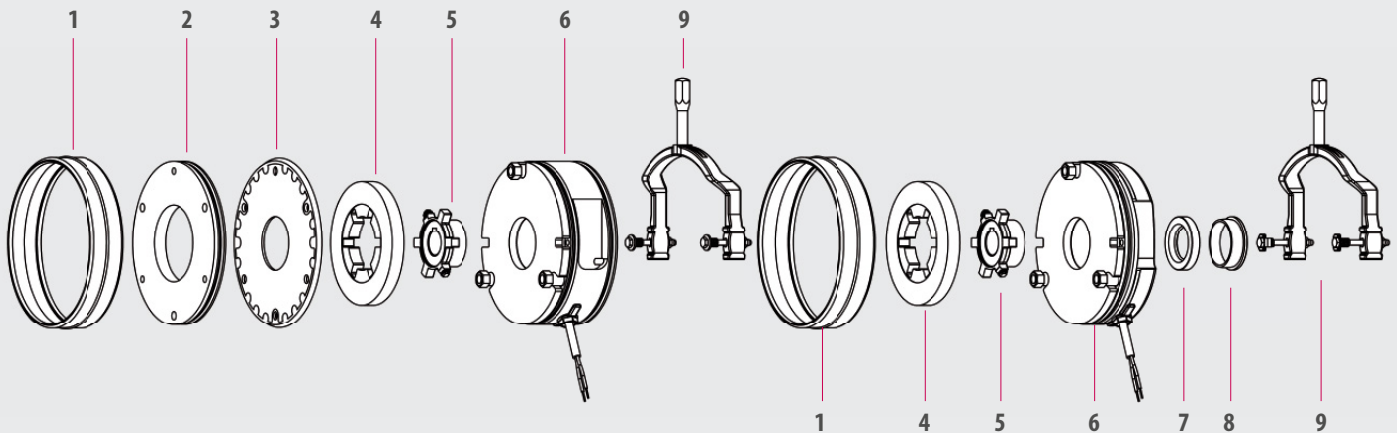

1. Dust protection ring 2. Flange 3. Friction disc 4. Friction lining 5. Hub 6. Magnet system 7. Shaft sealing ring 8. Sealing plug 9. Manual release



## HIGHLIGHTS

- Ten sizes
- Two redundant brake circuits
- Ready to install, adjusted air gap
- Used as a service brake or holding brake
- Up to Iso class H in accordance with VDE 0580
- CSA/CUS-certified
- Protection class up to IP67
- Designed for S1 operation or 100 % duty cycle
- Up to 7 million switching cycles as standard
- Standard voltages 24 / 105 / 180 / 205V

SIZE	Reduced torque [Nm]	Rated torque $M_2$ [Nm]*	Increased torque* [Nm]	Standard power P [W]	D [mm]	H [mm]	M [mm]	L [mm]	$d_{max}$ [mm]
02	2 x 3	2 x 6,5	2 x 10	2 x 25	85	105.5	72	84	15
03	2 x 4	2 x 13	2 x 20	2 x 30	102	114	90	96	20
04	2 x 8	2 x 25	2 x 40	2 x 30	127	128	112	111	25
05	2 x 15	2 x 45	2 x 65	2 x 48	147	166	132	124	30
06	2 x 33	2 x 90	2 x 120	2 x 62	164	176	145	144	35
07	2 x 65	2 x 130	2 x 200	2 x 65	190	225	170	165	45
08	2 x 75	2 x 200	2 x 300	2 x 75	218	235	196	177.5	60
09	2 x 120	2 x 330	2 x 500	2 x 80	253	256	230	206.5	60
10	2 x 165	2 x 665	2 x 1000	2 x 130	307	335	278	224	75
11	2 x 445	2 x 1335	2 x 2000	2 x 180	363	On request	325	On request	90

Braking torque tolerance  $\pm 25\%$  after pairing conditioning of the friction partners

\*Holding brake with emergency stop function

Assembly situation	Without options	With dust protection ring and shaft sealing ring* or sealing plug	Customized solution
Uncovered machine side	IP00	IP54	up to IP67
Under the fan cowl without manual release	IP54	IP55	up to IP67
Under the fan cowl with manual release	IP22	IP55	up to IP67

\*The protection class of the shaft sealing ring depends on the respective of the manufacturer

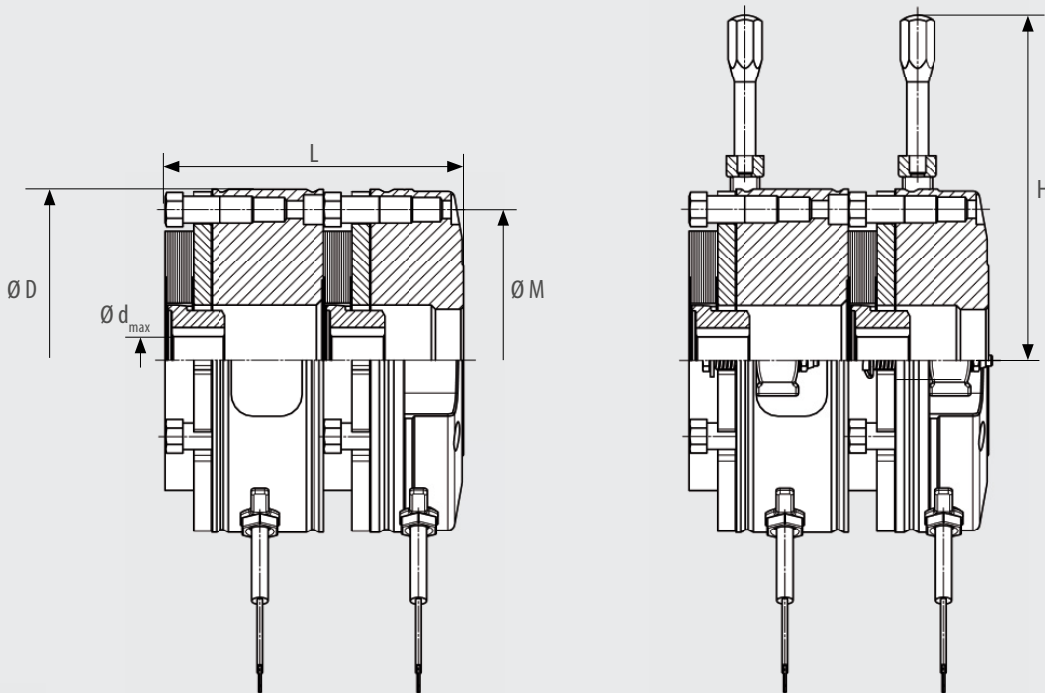

Download 3D models here and view further technical data

# COMBISTOP S1 – HIGH PERFORMANCE HOLDING BRAKE

The new S1 high-performance holding brake impresses with a new, patented friction system. This results in a significantly higher braking torque compared to conventional spring-applied brakes.

This is particularly suitable for servo applications with increased safety requirements. Thanks to the plug & play system, this series is also easy to assemble.

## OPTIONS:

- Felt ring
- CCV - Cold Climate Version down to 40 °C
- Modified braking torque
- Customized voltages
- Connector assembly
- Certificate 2.1 / acceptance test certificate 3.1

**NEW**

Braking torque on par with PM brakes

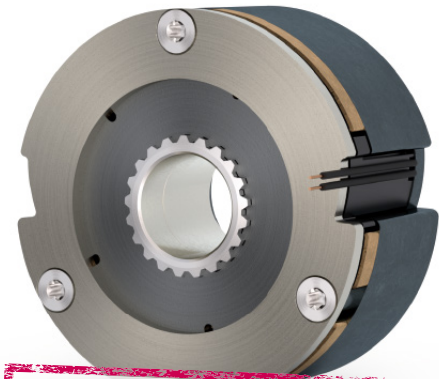

*Available on request*

**AREAS OF APPLICATION:** SERVO MOTORS | MEDICAL TECHNOLOGY | ROBOTICS AND AUTOMATION | INDUSTRIAL TRUCKS & AGVS  
E-MOBILITY | MATERIAL HANDLING

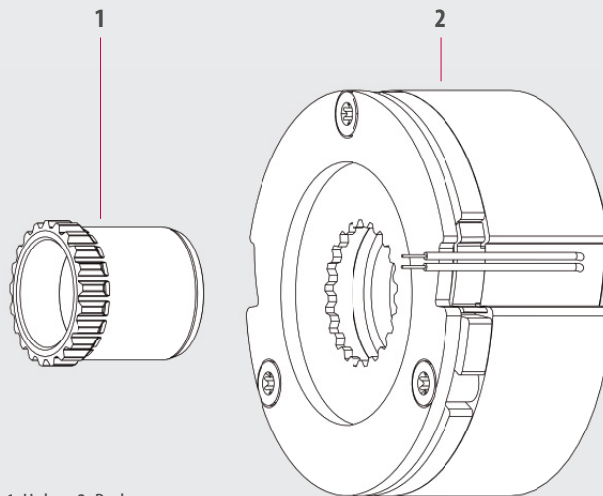

1. Hub 2. Brake



## HIGHLIGHTS

- Eight sizes
- High permissible emergency stop friction energy
- Stable brake torque
- High temperature resistance
- Ready to install, adjusted air gap
- Used as a service brake or holding brake
- Integrated cable slots
- Up to Iso class H in accordance with VDE 0580
- Designed for S1 operation or 100 % duty cycle
- Standard voltage 24V

SIZE	Rated torque $M_2$ [Nm]	$M_{4min120}$ [Nm]	Standard power $P$ [W]	D [mm]	$M^*$ [mm]	L [mm]	$d_{max}$ [mm]
01	0.5	0.3	6.1	35	24.5	30	9
02	1	0.6	7.5	41	28.8	30	10.5
03	1.9	1.1	9.4	48	33.7	31	12.5
04	3.9	2.3	11.8	56	39.3	32	15.5
05	7.5	4.5	15.3	66	46.3	34	17.5
06	15	9	20	77	54	37	20.5
07	30	18	26	90	63.1	39	24
08	60	36	33.8	102	73.6	42	28

Rated torque is reached after pairing conditioning of the friction partners

\*Standard mounting diameter, further diameters on request

Assembly situation	Without options
Uncovered machine side	IP00
Under the fan cowl without manual release	IP54

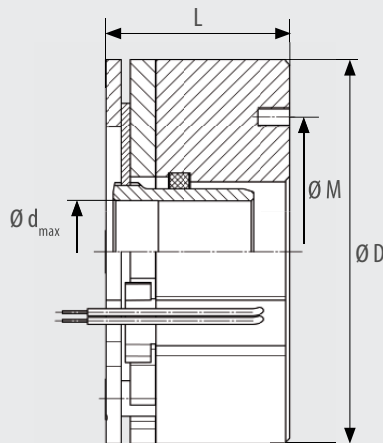

Download 3D models here and view further technical data

# COMBISTOP S1 FLAT – HIGH-PERFORMANCE HOLDING BRAKE

The new S1 flat high-performance holding brake impresses with a new, patented friction system. This results in a significantly higher braking torque compared to conventional spring-applied brakes.

The COMBISTOP S1 Flat fits perfectly with the requirements of AGVs and robotics & automation. Thanks to its plug & play system, this series is also easy to install.

## OPTIONS:

- CCV - Cold Climate Version down to 40 °C
- Modified braking torque
- Customised voltages
- Connector assembly
- Certificate 2.1 / acceptance test certificate 3.1

NEW

It couldn't be flatter

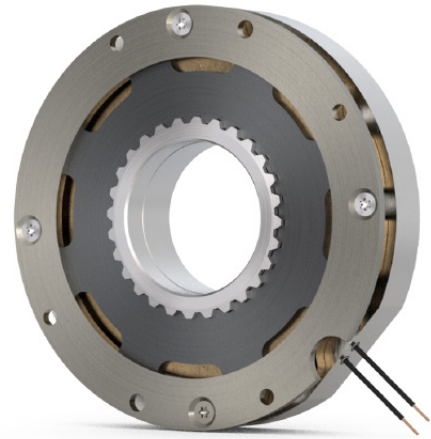

**AREAS OF APPLICATION:** INDUSTRIAL TRUCKS & AGVS | ROBOTICS AND AUTOMATION | SERVO MOTORS | MEDICAL TECHNOLOGY | E-MOBILITY | MATERIAL HANDLING

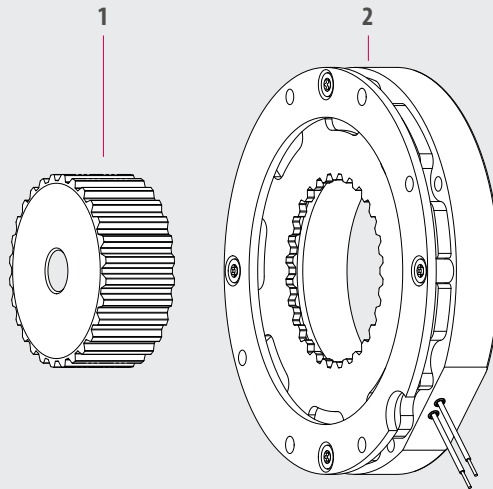

1. Hub 2. Brake



## HIGHLIGHTS

- Two sizes
- High permissible emergency stop friction energy
- Stable brake torque
- High temperature resistance
- Ready to install, adjusted air gap
- Used as a service brake or holding brake
- Integrated cable slots
- Up to Iso class F in accordance with VDE 0580
- Designed for S1 operation or 100 % duty cycle
- Standard voltage 24 V
- Further standard sizes to follow

SIZE	Rated torque $M_2$ [Nm]	$M_{4min80}$ [Nm]	Standard- power $P$ [W]	$D$ [mm]	$M^*$ [mm]	$L$ [mm]	$d_{max}$ [mm]
769	3.4	2.1	42	63.5	58	15.2	22
770	10.8	6.5	36	94	87	19.5	34

Rated torque is reached after pairing conditioning of the friction partners

\*Standard mounting diameter, further diameters on request

**CONTROL**

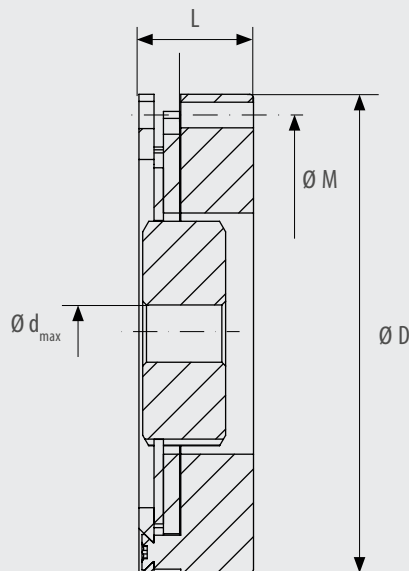
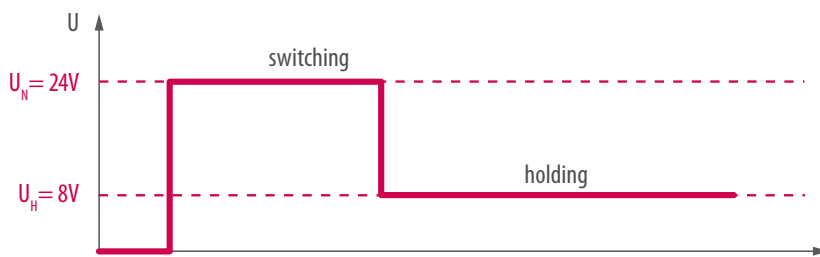

Download 3D models here and view further technical data

## WE START WHERE OTHERS STOP

In addition to our standard products, we develop and produce i based on technical customer specifications.

Due to our high vertical range of manufacture, our customers re series products can also be implemented quickly.

The KEB logo consists of the letters 'KEB' in a bold, white, sans-serif font, centered within a red rectangular background. The background of the entire page is a blurred industrial setting with a worker in the background and a row of cylindrical components in the foreground.

**KEB**

individual economical solutions -

receive prototypes in a short time. Product modification of existing

# COMBIPERM P1 – STANDARD PERMANENT MAGNET BRAKE

The COMBIPERM P1 is a powerful permanent magnet brake with a frictionally engaged, backlash-free effect. In the energised state, the magnetic field of the permanent magnet is cancelled and the connected component can rotate without residual torque. In the event of an emergency stop or if the power is switched off, the safety brake engages, brakes and holds the drive safely in position.

Thanks to the short switching times and the compact design, these brakes are ideal for servo motors and the medical industry.

## OPTIONS:

- VdS- monitoring
- Cable protection plate
- Felt ring
- Customized flange
- Customized voltage
- Customized plug
- Certificate 2.1 / acceptance test certificate 3.1



**AREAS OF APPLICATION:** SERVO MOTORS | MEDICAL TECHNOLOGY | ROBOTIC AND AUTOMATION | INDUSTRIAL TRUCKS & AGV'S  
ELECTROMOBILITY | INTRALOGISTICS



Download 3D models here and view further technical data

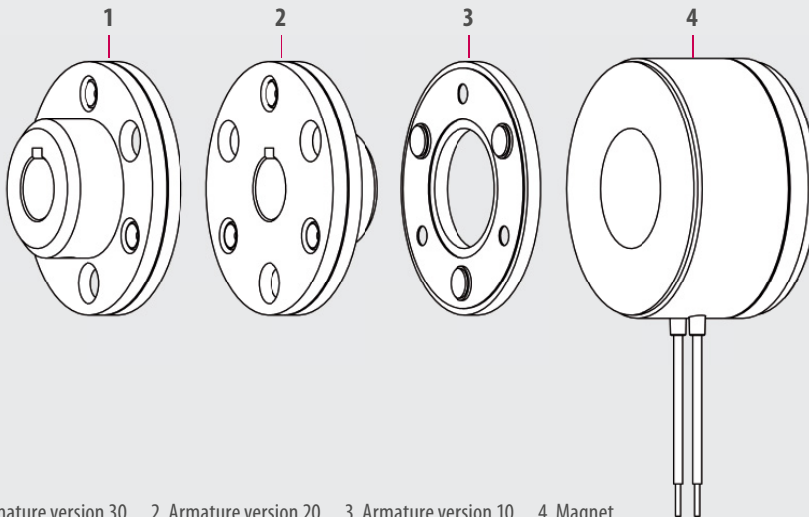

1. Armature version 30 2. Armature version 20 3. Armature version 10 4. Magnet



## HIGHLIGHTS

- Eleven sizes
- Backlash free
- Frictional engagement
- Release without residual torque
- ISO class F in accordance with VDE 0580
- CSA/CUS certification
- Designed for S1 operation or 100% duty cycle
- Up to ten million switching cycles as standard
- Up to 10,000 rpm
- Standard voltage 24V

SIZE	Rated torque $M_2$ [Nm]	$M_{4min 120}$ [Nm]	Standard power P [W]	D [mm]	$D_2$ [mm]	$D_3$ [mm]	$M^*$ [mm]	$M_2^*$ [mm]	L [mm]	$L_2$ [mm]	$L_3$ [mm]	$d_{max}$ [mm]
0A	0.15	0.1	3	-	-	18	15.2	-	-	-	20.75	3
01	0.5	0.3	8	39	32	28	33.5	22	21.9	23.9	28.9	6
02	1.4	0.8	10	45	34	32,2	38	23	23.75	25.75	33.75	8
03	2.7	1.8	11	54	42	41	47	28.5	25.25	27.85	37.25	12
04	3.5	2.8	11	60	45	42	52	34	28.6	32.1	40.9	12
05	6.1	4	12	65	53	51.5	58	40	31.7	34.7	43.7	15
06	12	8	18	80	66	64	72	49	31	34.5	46	18
07	24	15	24	100	83	80.8	90	63	34.7	38.7	54.7	25
08	49	32	26	125	103	101	112	78	40.45	45.45	65.45	30
09	96	65	40	150	128	126	137	106	45.5	51.5	75.5	40
10	194	115	50	190	163	161	175	135	52.5	59.5	90.5	50

Rated torque is reached after pairing conditioning of the friction partners \*Standard screw connection, customized screw connection on request

**OVERVIEW OF VARIANTS**

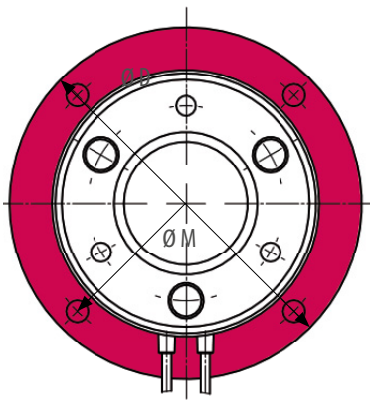

**Round flange**  
(Variant 100)

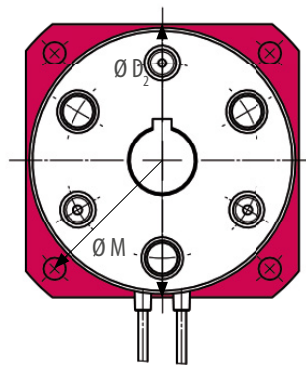

**Rectangular flange**  
(Variant 200)

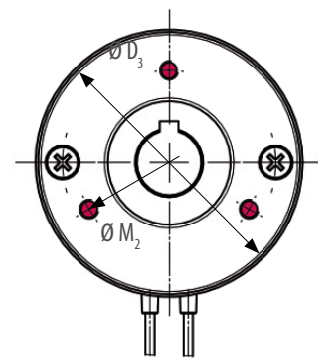

**Screw connection in the back**  
(Variant 300)

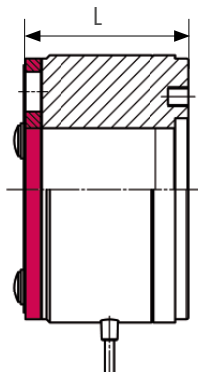

**Without hub**  
(Version 10)

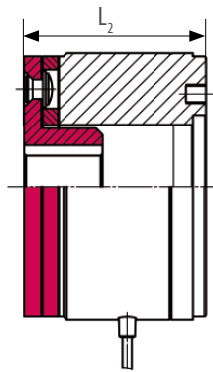

**Hub in the magnet**  
(Version 20)

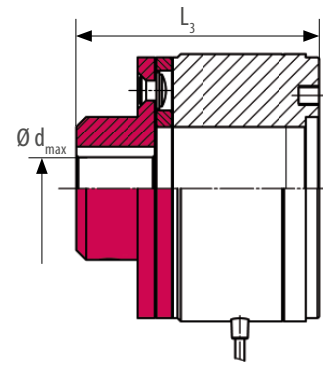

**Hub on the outside**  
(Version 30)

# COMBIPERM P2 – HIGH-PERFORMANCE PERMANENT MAGNET BRAKE

The COMBIPERM P2 is a very compact and powerful permanent magnet brake with frictionally engaged, backlash-free action.

Compared to the COMBIPERM P1, the brake is smaller in the installation space and requires less power with increased performance. In addition, due to its design, it can be used down to -40°C.

## OPTIONS:

- Cable-protection
- Customized flange and hub
- Customised storage recess
- Customized bolt circle
- Customized plugs
- Certificate 2.1 / acceptance test certificate 3.1

**NEW**

Braking torque at the highest level

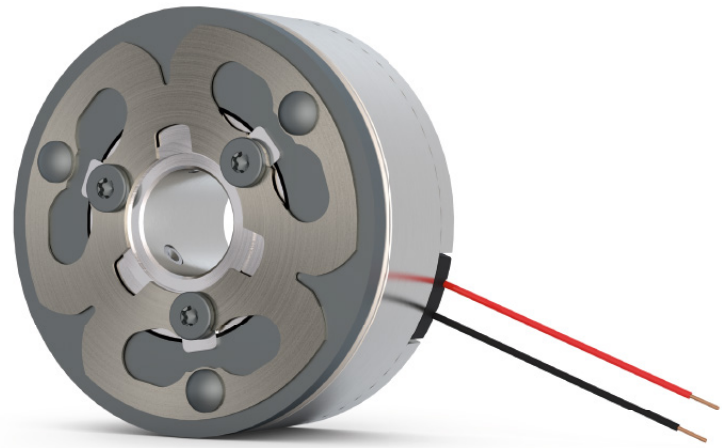

**AREAS OF APPLICATION:** SERVO MOTORS | MEDICAL TECHNOLOGY | ROBOTIC AND AUTOMATION | INDUSTRIAL TRUCKS & AGV'S  
ELECTROMOBILITY | INTRALOGISTICS

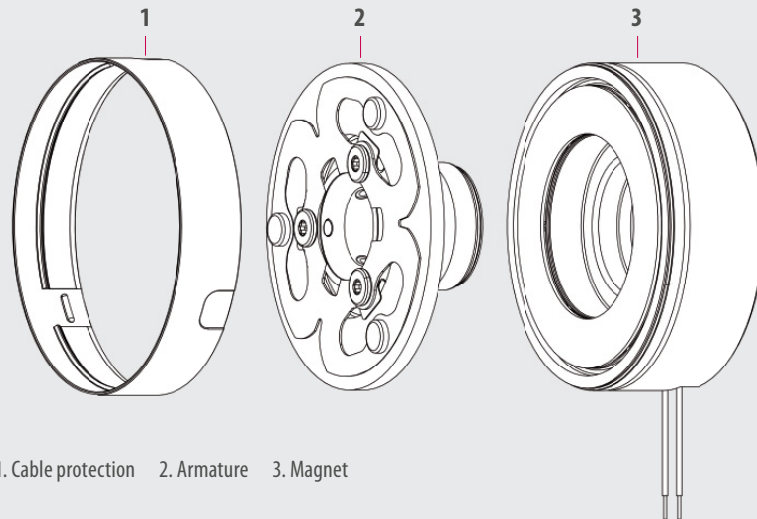

## HIGHLIGHTS

- Eight sizes
- Backlash free
- Frictional engagement
- Release without residual torque
- ISO class F in accordance with VDE 0580
- Designed for S1 operation or 100% duty cycle
- Up to ten million switching cycles as standard
- Up to 10,000 rpm
- Felt ring integrated
- Operation temperature -40°C - 120°C
- Standard voltage 24V

SIZE	Rated torque $M_2$ [Nm]	$M_{4min 120}$ [Nm]	Standard power $P$ [W]	$D$ [mm]	$M^*$ [mm]	$L$ [mm]	$d_{max Hub}$ [mm]
03	3	2.5	8	40	31	26	12
04	6	5	10	53	42	27	17
05	11	9	12	63	48	29	20
06	16	13	14	70	54	30	22
07	20	16	17	80	62	35	25
08	30	24.5	18	90	72	37.5	30
09	45	36	22	100	83	38	36
10	75	60	22	120	106	43	48

Rated torque after running in process \*Standard screw connection, customized screw connection on request

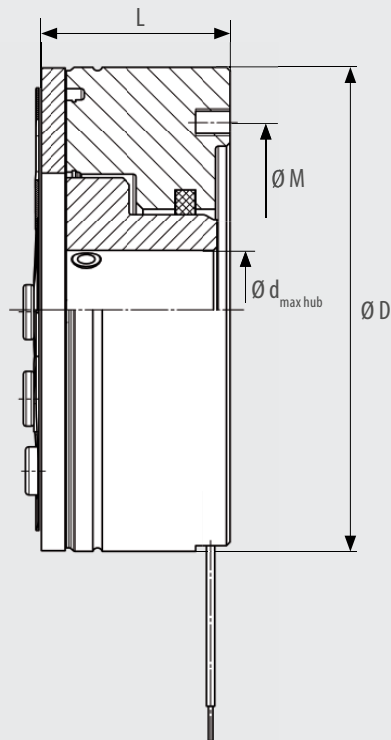

Download 3D models here and view further technical data

## COMBIPERM PC – PERMANENT MAGNET CLUTCH

Our COMBIPERM PC is a permanent magnet clutch that transmits torque frictionally when de-energised. High torques can thus be reliably transmitted in a small installation space.

The frictional connection is opened by applying a voltage so that the force effect of the permanent magnets is eliminated.

### OPTIONS:

- Customized flange
- Customized plugs
- Connector assembly
- Certificate 2.1 / acceptance test certificate 3.1



**AREAS OF APPLICATION:** MEDICAL TECHNOLOGY | WOOD WORKING MACHINES | ELECTROMOBILITY | INTRALOGISTICS  
PLASTIC TECHNOLOGY | PACKAGING MACHINES AND FOOD TECHNOLOGY

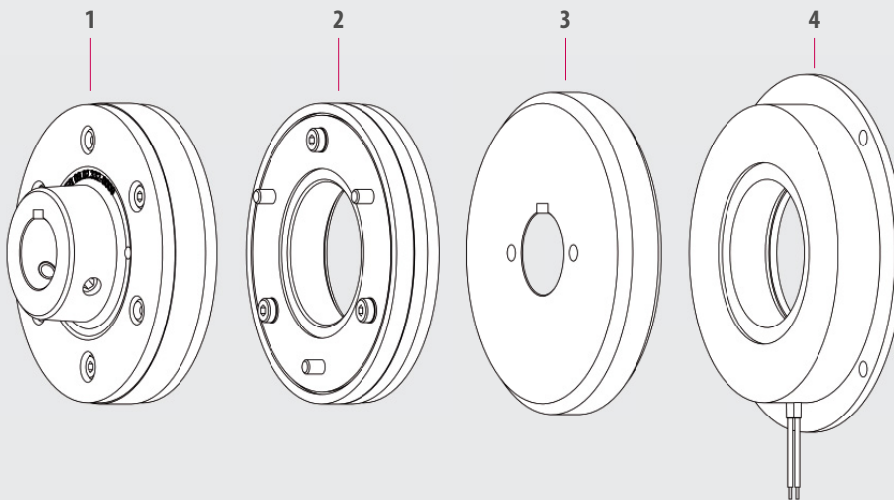

1. Armature version 30 2. Armature version 10 3. Rotor 4. Magnet



### HIGHLIGHTS

- Seven sizes
- Frictional engagement
- ISO class F in accordance with VDE 0580
- Designed for S1 operation or 100% duty cycle
- Standard voltage 24V

SIZE	Rated torque $M_2$ [Nm]	Standard power $P$ [W]	D [mm]	M [mm]	L [mm]	$L_2$ [mm]	$d_{\max \text{ Rotor}}$ [mm]	$d_{\max \text{ Hub}}$ [mm]
03*	1.5	13	54	47	47.55	35.55	10	10
05*	3	10	65	58	51.2	39.2	15	15
06	6	18	80	72	51.8	36.8	20	18
07	12	24	100	90	60.8	40.8	25	22
08	24	28	125	112	73.35	48.35	30	30
09	50	35	150	137	84.4	54.4	35	35
10	120	80	190	175	100	62	50	45

Rated torque is reached after pairing conditioning of the friction partners

\* Quantity dependent project solution

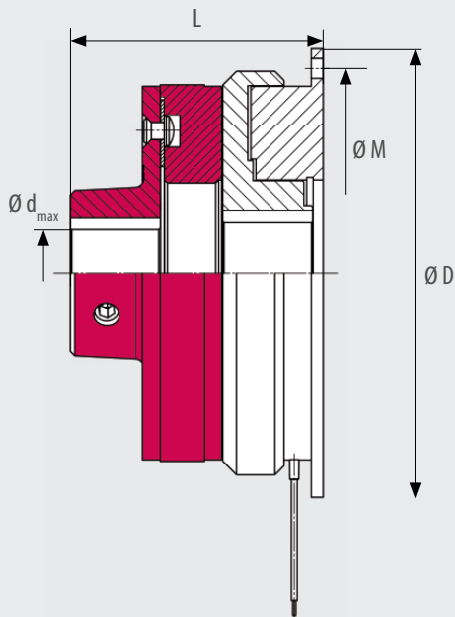

**Hub on the outside**  
(Variant 130)

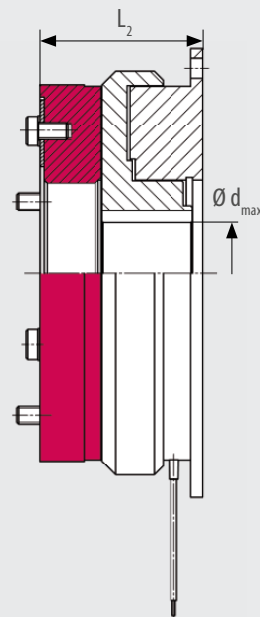

**Without hub**  
(Variant 110)



Download 3D models here and view further technical data

## COMBINORM B – ELECTROMAGNETIC BRAKE

The operating current brake COMBINORM B opens when the power supply is switched off or in the event of a power failure. The electromagnetic brake is particularly suitable for precise positioning and reliable holding.

It is also used in safety and access technology, e.g. in the area of access barriers or fire doors. The electromagnetic brake is designed for a 100 % duty cycle and can optionally be certified to VdS. The electromagnetic brake has a torque range of 0.5 to 500 Nm.

### OPTIONS:

- Customized flange
- CSA / CUS Certification
- Customized voltage
- Customized plug
- Certificate 2.1 / acceptance test certificate 3.1
- Anti-remnance
- Interlocking toothed version for torque increase



**AREAS OF APPLICATION:** MEDICAL TECHNOLOGY | DOOR AND GATE OPERATOR | WOOD WORKING MACHINES  
ELECTROMOBILITY | ROBOTIC AND AUTOMATION | PACKAGING MACHINES AND FOOD TECHNOLOGY  
AGRAR- MINING- AND MUNICIPAL MACHINERY

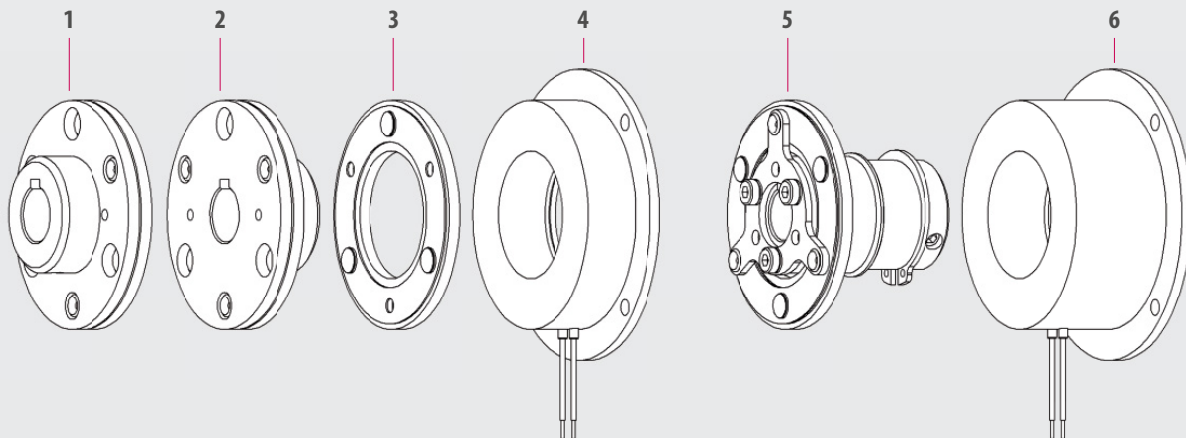

1. Armature version 30   2. Armature version 20   3. Armature version 10   4. Magnet flange mounted   5. Armature shaft mounted   6. Magnet shaft mounted



### HIGHLIGHTS

- Thirteen sizes
- Short switching times
- Positioning accuracy and functional reliability
- Designed for S1 operation or 100% duty cycle
- ISO class B in accordance with VDE 0580
- Wide temperature and voltage range
- Continuously adjustable torque
- Standard voltage 24V

SIZE	Rated torque M <sub>2</sub> [Nm]	Standard power P [W]	D [mm]	M [mm]	L [mm]	L <sub>2</sub> [mm]	L <sub>3</sub> [mm]	L <sub>4</sub> [mm]	d <sub>max</sub> [mm]
01	0.5	6	39	33.5	16.1	18.1	23.1	-	6
02	0.75	6	45	38	19.25	21.25	29.25	-	8
03	1.5	8	54	47	22.85	25.45	34.85	-	10
05	3	10	65	58	25.2	28.2	37.2	-	15
06	7	12	80	72	22	25.5	37	37.7	20
07	15	16	100	90	24.5	28.5	44.5	41.3	22
08	30	21	125	112	28.2	33.2	53.2	47.5	30
09	65	28	150	137	31.2	37.2	61.2	51.2	35
10	130	38	190	175	35.2	42.2	73.2	60.7	45
11	250	50	230	215	41.6	50.6	89.6	-	60
12	500	65	290	270	48.4	59.4	103.4	-	70
13*	750	80	355	335	60.4	73	124	-	90
14*	1250	100	440	420	75.5	92.5	151.5	-	100

Rated torque is reached after pairing conditioning of the friction partners

\* Quantity dependent project solution

**FLANGE MOUNTED VERSION:**

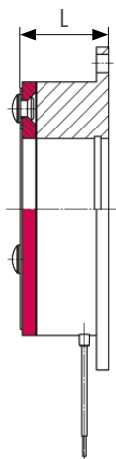

**Without hub**  
(Variant 110)

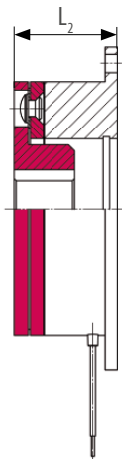

**Hub in the magnet**  
(Variant 120)

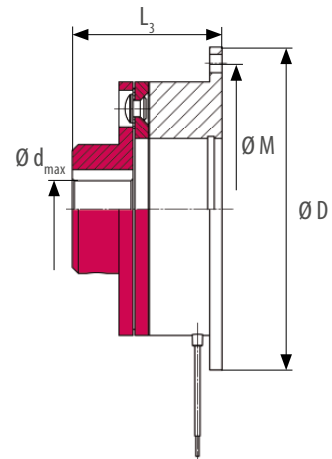

**Hub on the outside**  
(Variant 130)

**SHAFT MOUNTED BRAKE:**

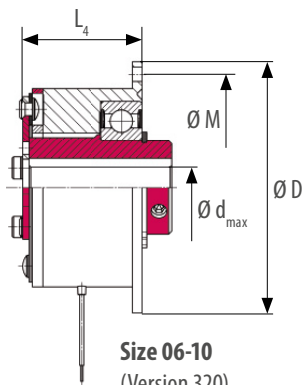

**Size 06-10**  
(Version 320)



Download 3D models here and view further technical data

# COMBINORM C – ELECTROMAGNETIC CLUTCH

The operating current clutch COMBINORM C provides clutch engagement when electrically powered. As a result it enables particularly simple controlled switching on and off of functional parts.

The electromagnetic clutch is suitable for reliable positioning and torque transmission of switchable shaft connections in synchronised processes. The electromagnetic clutch has a torque range of 0.5 to 500 Nm.

## OPTIONS:

- Customized flange
- CSA / CUS certificate
- Customized voltage
- Customized plugs
- Certificate 2.1 / acceptance test certificate 3.1

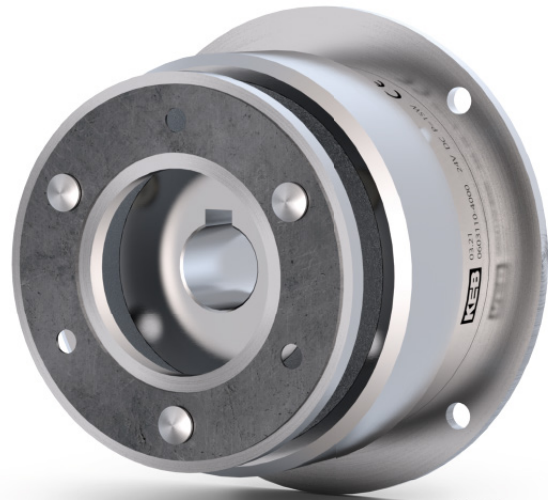

**AREAS OF APPLICATION:** MEDICAL TECHNOLOGY | DOOR AND GATE OPERATOR | WOOD WORKING MACHINES  
ELECTROMOBILITY | ROBOTIC AND AUTOMATION | PACKAGING MACHINES AND FOOD TECHNOLOGY  
AGRAR- MINING- AND MUNICIPAL MACHINERY

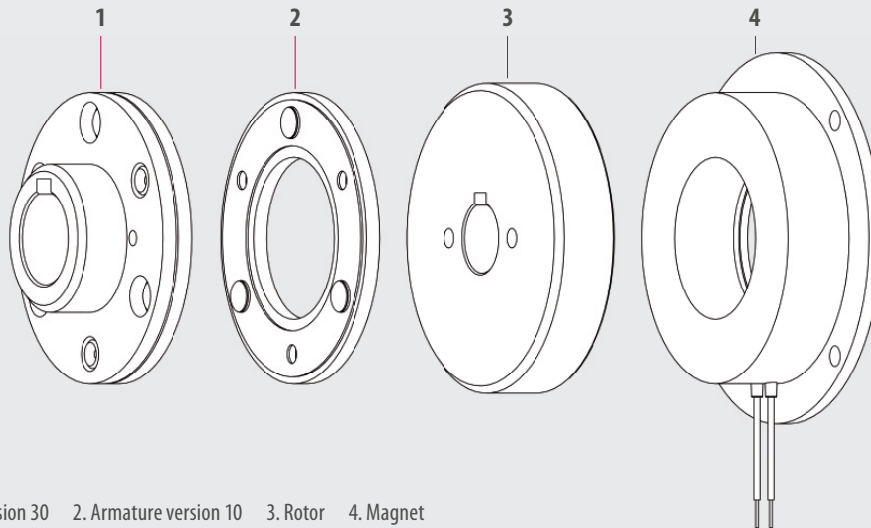

1. Armature version 30 2. Armature version 10 3. Rotor 4. Magnet



## HIGHLIGHTS

- Thirteen sizes
- Short switching times
- Positioning accuracy and functional reliability
- Designed for S1 operation or 100% duty cycle
- ISO class B in accordance with VDE 0580
- Wide temperature and voltage range
- Continuously adjustable torque
- Standard voltage 24V

SIZE	Rated torque M <sub>2</sub> [Nm]	Standard power P [W]	D [mm]	M [mm]	L [mm]	L <sub>2</sub> [mm]	d <sub>max Rotor</sub> [mm]	d <sub>max Hub</sub> [mm]
01	0.5	6	39	33.5	20.4	27.4	6	6
02	0.75	6	45	38	24.45	34.45	8	8
03	1.5	8	54	47	28.25	40.25	10	10
05	3	10	65	58	31.3	43.3	17	15
06	7	15	80	72	28	43	20	18
07	15	20	100	90	31	51	25	22
08	30	28	125	112	36.2	61.2	30	30
09	65	35	150	137	40.7	70.7	35	35
10	130	50	190	175	46.7	84.7	50	45
11	250	68	230	215	55.6	103.6	65	60
12*	500	85	290	270	64.4	119.4	80	70
13*	750	On request	355	335	78	127	90	90
14*	1250	On request	440	420	On request			

Rated torque is reached after pairing conditioning of the friction partners

\*Quantity dependent project solution

**FLANGE MOUNTED VERSION:**

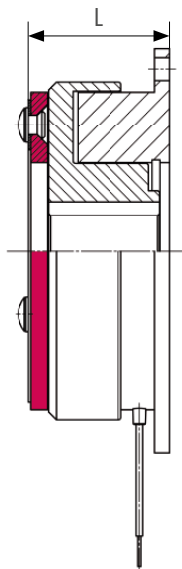

**Without hub**  
(Variant 110)

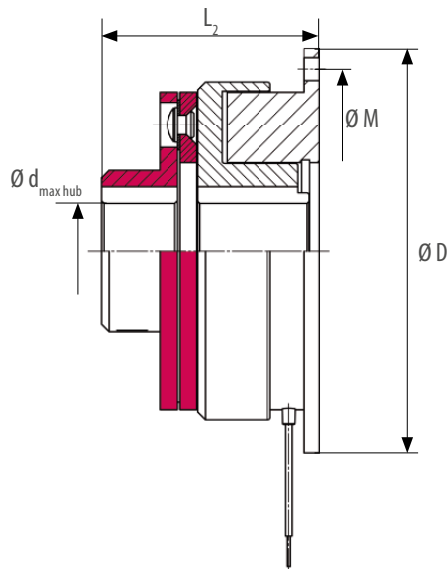

**Hub on the outside**  
(Variant 130)



Download 3D models here and view further technical data

# COMBINORM C – VARIANTS 210 / 230 / 810

SIZE	Rated torque $M_z$ [Nm]	Standard power $P$ [W]	D [mm]	M [mm]	L [mm]	$L_2$ [mm]	$L_3$ [mm]	$d_{\max \text{ Rotor}}^*$ [mm]	$d_{\max \text{ Hub}}$ [mm]
06	7	15	80	72	45	60	80	17	18
07	15	20	100	90	49.5	69.5	90	22	22

Rated torque is reached after pairing conditioning of the friction partners

\*More customized max. diameter on request

## FLANGE MOUNTED VERSIONS WITH BEARING MOUNTED ROTOR:

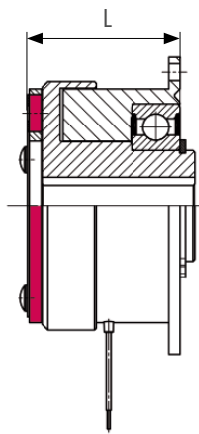

**Without hub**  
(Variant 210)

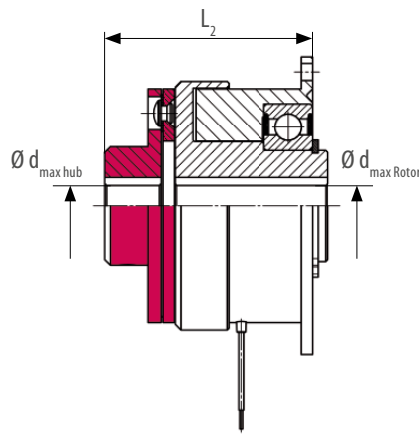

**Hub on the outside**  
(Variant 230)

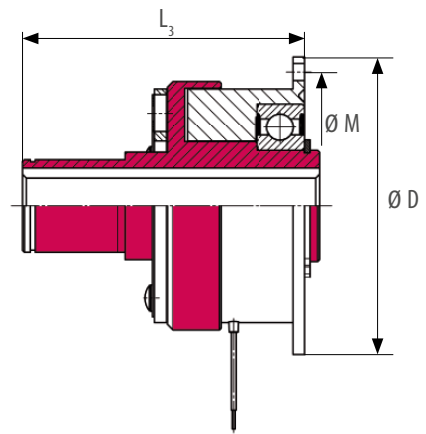

**Rotor for bearing**  
(Variant 810)

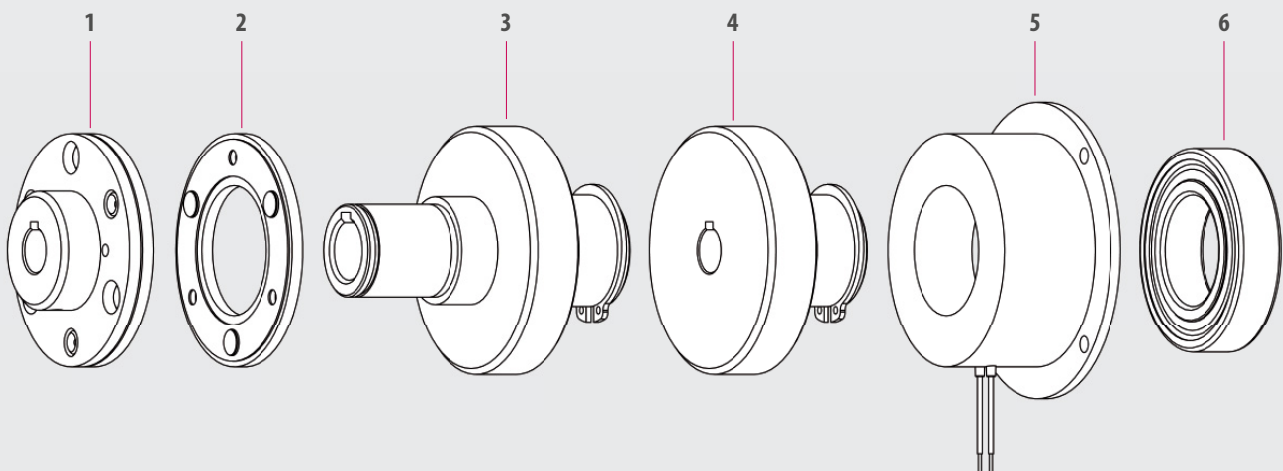

1. Armature version 30 2. Armature version 10 3. Rotor for bearing 4. Rotor 5. Magnet 6. Bearing

SIZE	Rated torque $M_2$ [Nm]	Standard power $P$ [W]	D [mm]	M [mm]	L [mm]	$L_2$ [mm]	$L_3$ [mm]	$L_4$ [mm]	$d_{\max \text{ Rotor}}$ [mm]	$d_{\max \text{ Hub}}$ [mm]	$d_{\max \text{ Hub2}}$ [mm]
01	0.5	6	31	16.8	19.7	26.7	26.7	1.5	6	6	6
02	0.75	6	34	20	22.05	32.05	32.05	1.5	6	8	6
03	1.5	8	43	23	25.85	37.85	37.85	1.5	10	10	10
05	3	10	54	28	29.3	41.3	41.3	1.5	17	15	15
06	7	15	67	36	28	43	-	2.5	20	18	-
07	15	20	85	45	31	51	-	2.5	25	22	-

Rated torque is reached after pairing conditioning of the friction partners

### SHAFT MOUNTED VERSIONS WITH PLAIN-BEARING FOR THE ROTOR:

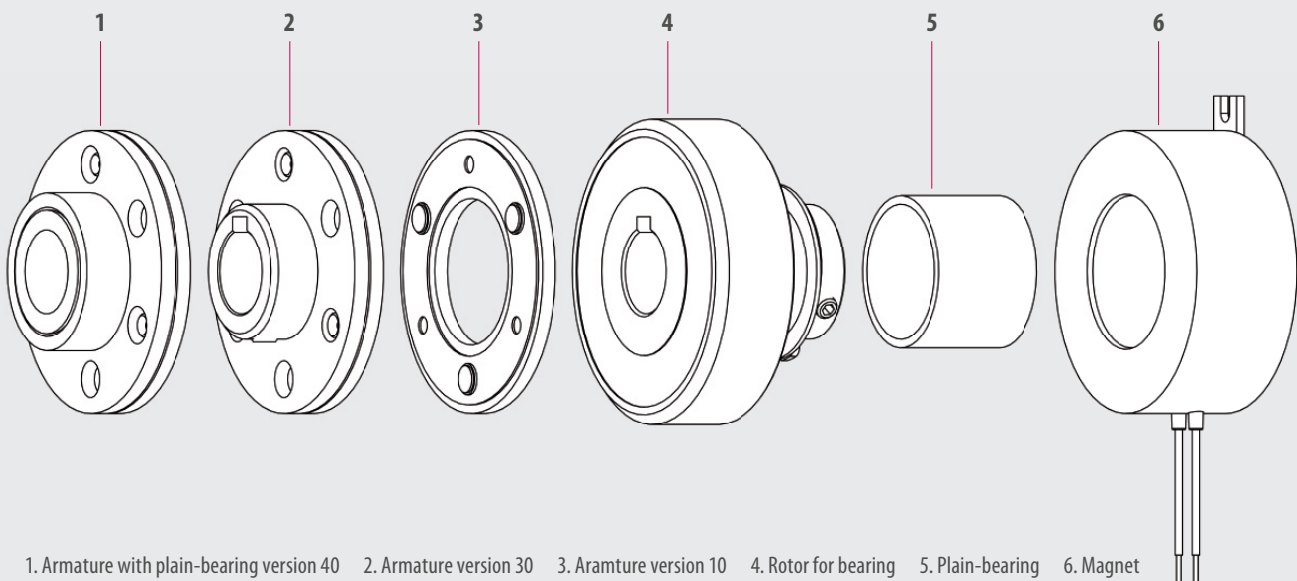
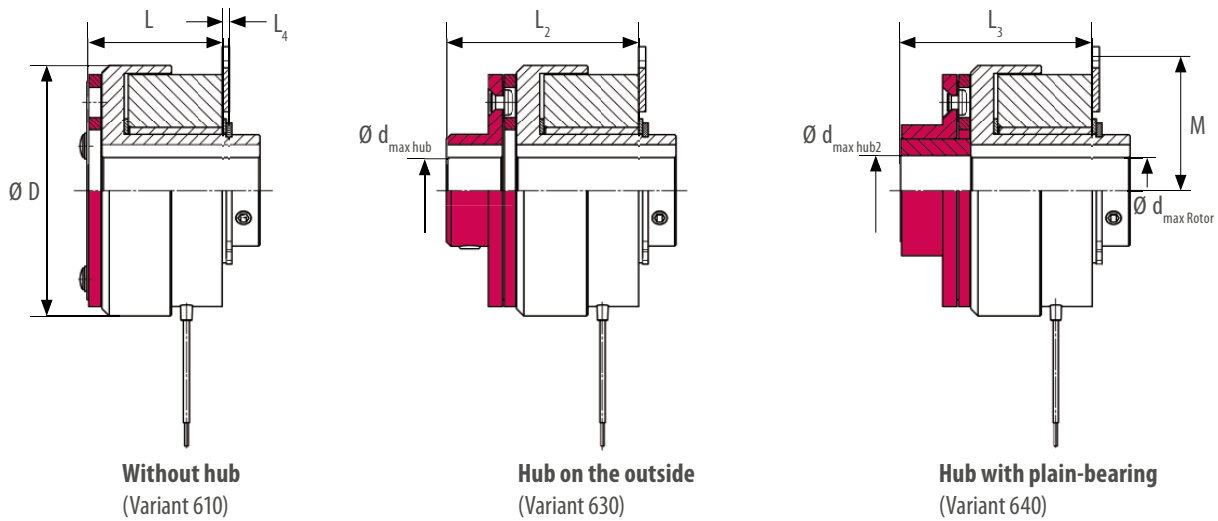

# COMBINORM C – VARIANTS 710 / 730 / 810

SIZE	Rated torque $M_2$ [Nm]	Standard power $P$ [W]	D [mm]	M [mm]	L [mm]	$L_2$ [mm]	$L_3$ [mm]	$d_{\max \text{ Rotor}}^*$ [mm]	$d_{\max \text{ Hub}}^*$ [mm]
08	30	28	106	56	41.5	66.5	96	30	30
09	65	35	133	68.5	43.5	73.5	103	35	35
10	130	50	169	87.5	52.7	90.7	126	50	45
11	250	68	212.5	107.5	59.45	107.4	134	50	60
12**	500	85	266	135	71.4	125.6	162	80	70

Rated torque is reached after pairing conditioning of the friction partners  
 \*\*Quantity dependent project solution

\*More customized max. diameter on request

## SHAFT MOUNTED VERSIONS WITH BEARING MOUNTED ROTOR:

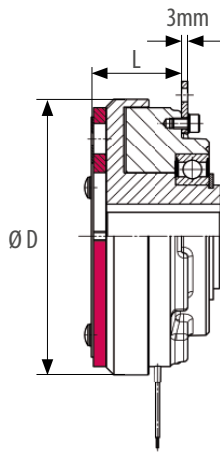

**Without hub**  
(Variant 710)

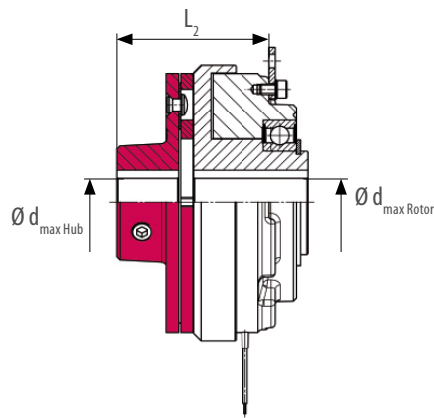

**Hub on the outside**  
(Variant 730)

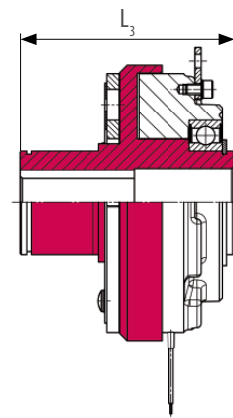

**Rotor for bearing**  
(Variant 810)

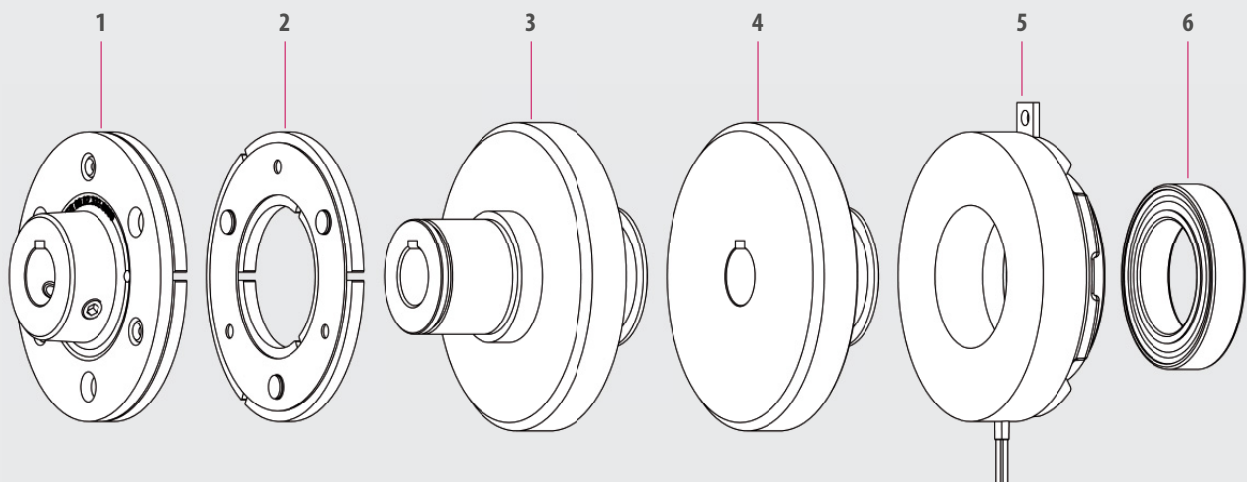

1. Armature version 30 2. Armature version 10 3. Rotor for bearing 4. Rotor 5. Magnet 6. Bearing

SIZE	Rated torque $M_2$ [Nm]	Standard power $P$ [W]	D [mm]	$D_2$ [mm]	M [mm]	L [mm]	$d_{\max \text{ Rotor}}$ [mm]	$d_{\max \text{ Hub}}$ [mm]
06	7	15	67	56	72	117	20	19
07	15	20	85	85	90	129	25	26
08	30	28	106	100	-	141	30	30
09	65	35	133	120	-	160	35	38
10	130	50	169	170	-	200	50	55
11	250	68	212.5	200	-	217	65	65
12*	500	85				on request		

Rated torque is reached after pairing conditioning of the friction partners

\*\*Quantity dependent project solution

### SHAFT OR FLANGE MOUNTED VERSION WITH ELASTIC CLUTCH:

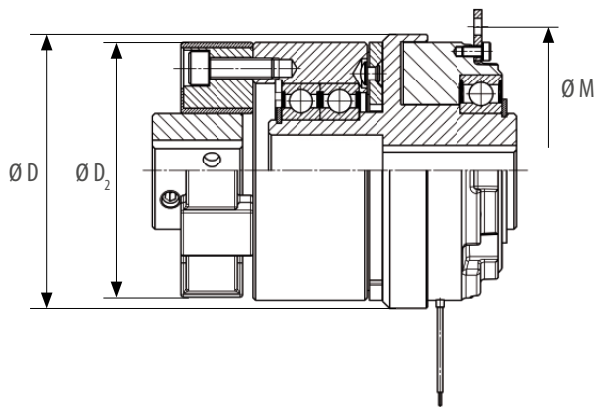

**Shaft-mounted**  
(Size 08-12)

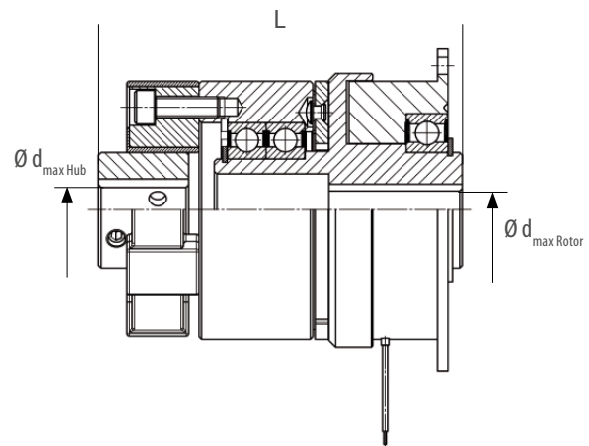

**Flange-mounted**  
(Size 06-07)

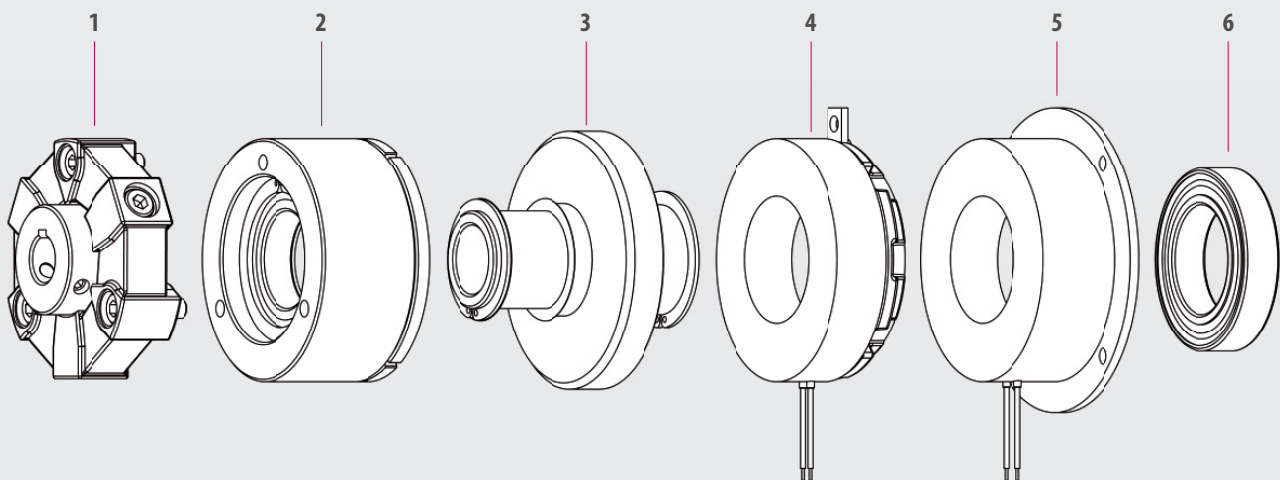

- 1. Elastic clutch
- 2. Armature
- 3. Rotor
- 4. Magnet (shaft-mounted size 08-12)
- 5. Magnet (Flange-mounted size 06-07)
- 6. Bearing

## COMBINORM T – ELECTROMAGNETIC TOOTH CLUTCH

Like the COMBINORM C, the operating current clutch COMBINORM T engages when electrically powered. However, this device is designed as an electromagnetically operated tooth clutch. Through the positive connection, particularly large torques are transmitted in both directions within a small space by restricting the speed of incidence.

In the process, torque is applied by the leading faces of hardened serrations and is backlash-free. The electromagnetic tooth clutch has a torque range of 21 to 390 Nm.

### OPTIONS:

- Customized flange
- CSA / CUS certificate
- Customized voltage
- Customized plugs
- Factory certificate 2.1 / inspection certificate 3.1



**AREAS OF APPLICATION:** MEDICAL TECHNOLOGY | DOOR AND GATE OPERATOR | WOOD WORKING MACHINES  
PACKAGING MACHINES AND FOOD TECHNOLOGY | INTRALOGISTICS

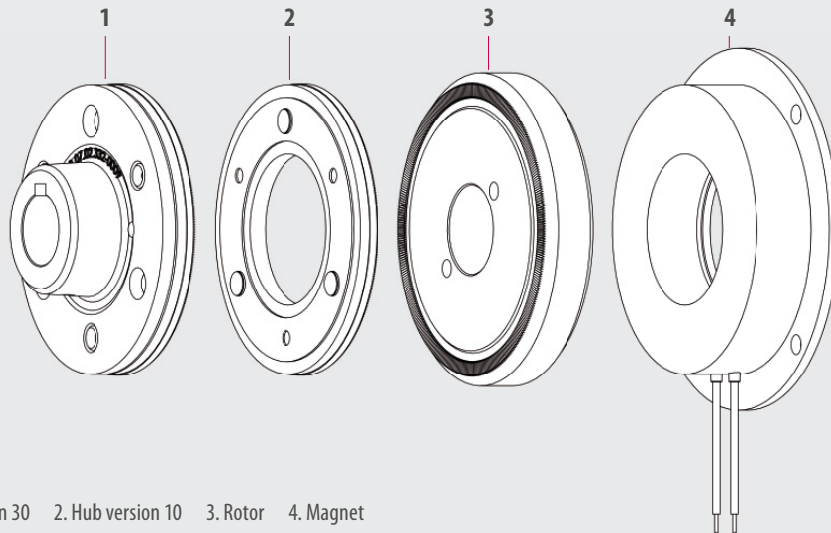

1. Armature version 30 2. Hub version 10 3. Rotor 4. Magnet



### HIGHLIGHTS

- Five sizes
- Backlash free
- Iso class B accordance with VDE 0580
- Designed for S1 operation or 100% duty cycle
- wide temperature and voltage range
- Standard voltage 24V

SIZE	Rated torque $M_2$ [Nm]	Standard power $P$ [W]	D [mm]	M [mm]	L [mm]	$L_2$ [mm]	$L_3$ [mm]	$d_{\max \text{ Rotor}}$ [mm]	$d_{\max \text{ Hub}}$
06	21	15	80	72	29.45	44.45	20	18	18
07	45	20	100	90	33.1	53.1	25	22	22
08	90	28	125	112	38.8	63.8	30	30	30
09	195	35	150	137	44.9	74.9	35	35	35
10	390	50	190	175	50.55	88.55	50	45	45

*Rated torque is immediatly reachable*

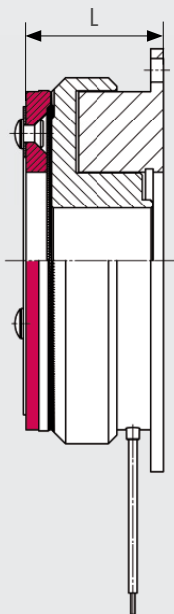

**Without hub**  
(Variant 110)

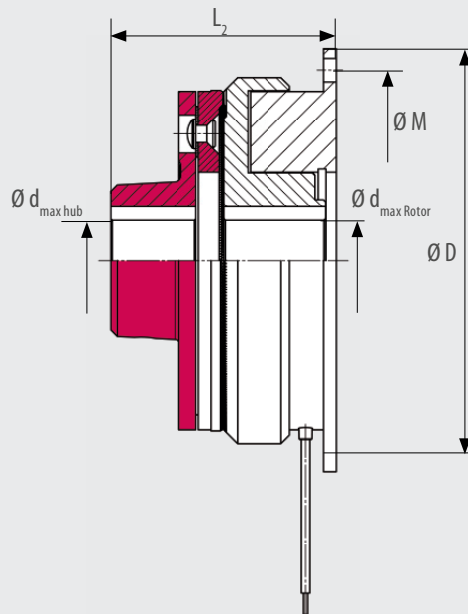

**Hub on the outside**  
(Variant 130)



Download 3D models here and view further technical data

## COMBITRON 91 – RECTIFIER

COMBITRON 91 rectifiers are half-wave or bridge rectifiers for supplying electromagnets with a supply voltage of up to max. 720 V AC for DC or AC side switching in accordance with the 73/231/EEC Low Voltage Directive.

When switching electromagnetic clutches and brakes and other inductive DC consumers, harmful electromagnetic interference can occur.

Our half-wave rectifier with interference suppression limits the interference to class A in accordance with EN 55011.



Input voltage $U_{in}$ [V AC]	max. Input voltage $U_{in max}$ [V AC]	max. Cut-off voltage [V]	Switching mode	Nominal voltage magnet [V DC]*	Type of rectifier
48	275	450	Half wave	20	0291010-CE07
			Full wave	42	0291020-CE07
110	275	450	Full wave	105	0291020-CE07
			220 / 230	275	450
Full wave	205	0291020 - CE07			
Half wave with EMC protection	105	0291010 - CEMV			
380 / 400	500	900	Half wave	180	0491010 - CE07
			Full wave	380	0491020 - CE07
380 / 400	600	1000	Half wave	on request	0591010 - CE09
600 / 690	720	1600	Half wave	on request	0691010 - CE09

\* Half-wave rectifier:  $0,45 \cdot U_{in}$  Full wave:  $0,9 \cdot U_{in}$



Download 3D models here and view further technical data



### HIGHLIGHTS

- Half-wave or bridge rectifier
- Up to 720 V
- UL-certified
- Compact design in plastic housing
- DC-side and AC-side switching

With the COMBITRON 98, KEB offers a fast-acting rectifier with overexcitation for optimum activation or deactivation times for spring-applied brakes and electromagnets. Two powerbox designs in rigid housing for fitting on DIN rails or as a screw-on version complete the range.

The advantages of COMBITRON 98 become clear in practice, as faster switching times and the possibility of achieving significant energy savings make the fast-acting rectifier a highly sought-after “assistant”.



	9098210 - CE04	9098200 - CE09 <sup>1)</sup>
Input voltage	24 V DC ± 20%	180-300 V AC ± 0%
Overexcitation time	800 ms ± 15%	350 ms ± 10%
Current I <sub>N</sub> 45°C	1.2 A continuous 7 A für 800 ms	1.2 A continuous 2.4 A für 350 ms
Current I <sub>N</sub> 75°C	0.6 A continuous 3.5 A für 800 ms	0.7 A continuous 1.4 A für 350 ms
Temperature	CCV -40° ... 75°	CCV -40° ... 75°
Switching rate	max. 6 per minute at max. current	max. 1 per minute at max. current

<sup>1)</sup> different values (U, A) when used under conditions of UL



Download 3D models here and view further technical data



## HIGHLIGHTS

- Two versions
- Up to 94 % power reduction
- Overexcitation possibility
- Up to 300 V
- UL-certified
- Compact design in plastic housing
- Low level of intrinsic heating
- DC-side and AC-side switching

# CUSTOMISED BRAKES AND CLUTCHES

## IF THE STANDARD VERSION DOES NOT DO WHAT YOU NEED, WE CAN DEVELOP A SOLUTION FOR YOU

Implementing customer-specific product solutions is one of KEB Automation's core competencies thanks to decades of experience, in-depth expertise and a high level of in-house vertical integration.

We work in partnership with you to develop high-quality, customised solutions in the area of spring-applied brakes, permanent magnet brakes and clutches, as well as electromagnetic clutches and brakes. By individually analysing your requirements and needs, we design the right product for your application.

### EXAMPLE MODIFICATIONS SPRING-APPLIED BRAKES

- Multi-surface and double rotor brakes
- Lockable hand release
- Customised brake torque tolerances
- Customised sizes/dimensions
- Bistable solutions for saving energy

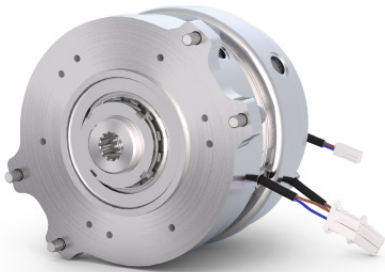

**Double brake with additional single surface brake**



**Spring-applied brake with lockable hand release**



**Bistable spring applied brake for energy saving**



### HIGHLIGHTS

- 90 % in-house production possibility at KEB
- Magnetic flux simulation
- Strength analysis
- 3D rapid prototyping
- 100 % torque testing possible

### EXAMPLE MODIFICATIONS PERMANENT MAGNET BRAKES

- Plug-and-play solutions
- Individual external dimensions and intermediate sizes
- Adapted temperature range
- Automated air gap adjustment
- Redundant coil and bistable brake solutions

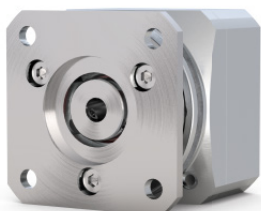

**Plug&Play Permanent Magnet brake**



**Floating supported permanent magnet brake**

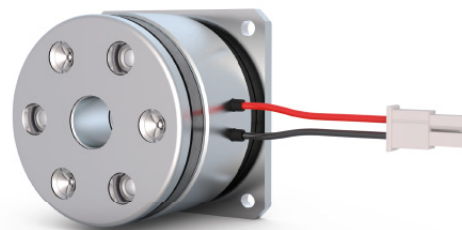

**Individual intermediate size**

### EXAMPLE MODIFICATIONS ELECTROMAGNETIC BRAKES AND CLUTCHES

- Complete mounting units
- Integrated bearing
- Multipole solution for increased torque
- Anti-remanence function
- Narrow torque window



**Plug&Play unit for the automotive Sector**

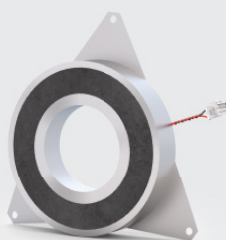

**Holding magnet with spring plates**

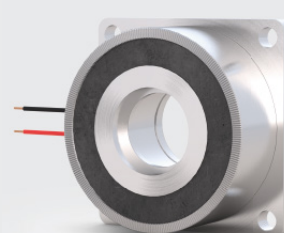

**Toothed power brake**



## RELIABLE, SAFE AND ECONOMICAL

Electricity and magnetism cannot be separated from each other. Electromagnetism is considered one of the four elemental forces, through which one of the most important power transmissions in modern drive technology is available.

KEB uses this force sensibly and purposefully. Switching machine segments on and off, safely stopping and holding loads or dynamic positioning...

Electromagnetic assemblies offer the designer economical, robust, safe and reliable options for the individual solution.



### THE MAIN APPLICATIONS ARE:

- Gear and servo motors
- Medical technology
- Robotics and automation
- Cranes, hoists and trolleys
- Intralogistics
- Wind energy

## KEB'S COUNTRY ORGANISATIONS

**Austria** | KEB Automation GmbH  
Ritzstraße 8 4614 Marchtrenk Austria  
Phone: +43 7243 53586-0 Fax: +43 7243 53586-21  
E-Mail: info@keb.at Web: keb-automation.com

**Benelux** | KEB Automation KG  
Boulevard Paepsem 20 – Paepsemlaan 20 1070 Anderlecht Belgium  
Phone: +32 2 447 8580  
E-Mail: info.benelux@keb.de Web: keb-automation.com

**Czech Republic** | KEB Automation s.r.o.  
Videnska 188/119d 61900 Brno Czech Republic  
Phone: +420 544 212 008  
E-Mail: info@keb.cz Web: keb-automation.com

**France** | Société Française KEB SASU  
Z.I. de la Croix St. Nicolas 14, rue Gustave Eiffel  
94510 La Queue en Brie France  
Phone: +33 149620101 Fax: +33 145767495  
E-Mail: info@keb.fr Web: keb-automation.com

**Germany | Geared Motors**  
KEB Antriebstechnik GmbH  
Wildbacher Straße 5 08289 Schneeberg Germany  
Phone: +49 3772 67-0 Fax +49 3772 67-281  
E-Mail: info@keb-drive.de Web: keb-automation.com

**Germany | Headquarters**  
KEB Automation KG  
Südstraße 38 32683 Barntrup Germany  
Phone: +49 5263 401-0  
E-Mail: info@keb.de Web: keb-automation.com

**Italy** | KEB Italia S.r.l. Unipersonale  
Via Newton, 2 20019 Settimo Milanese (Milano) Italy  
Phone: +39 02 3353531 Fax: +39 02 33500790  
E-Mail: info@keb.it Web: https://blog.keb.it

**Japan** | KEB Japan Ltd.  
711-103 Fukudayama, Fukuda,  
Shinjo-shi Yamagata 996-0053 Japan  
Phone: +81 233 292800 Fax: +81 233 292802  
E-Mail: info@keb.jp Web: keb.jp

**P. R. China** | KEB Power Transmission Technology (Shanghai) Co. Ltd.  
No. 435 QianPu Road Chedun Town Songjiang District  
201611 Shanghai P. R. China  
Phone: +86 21 37746688 Fax: +86 21 37746600  
E-Mail: info@keb.cn Web: keb.cn

**Poland** | KEB Automation KG  
Phone: +48 604 077 727  
E-Mail: roman.trinczek@keb.de Web: keb-automation.com

**Republic of Korea** | KEB Automation KG  
2408, 36 Teheran-ro 87-gil, Gangnam-gu, Seoul, Republic Korea  
Phone: +82 10 3101 3902  
E-Mail: vb.korea@keb.de Web: keb-automation.com

**Spain** | KEB Automation KG  
c / Mitjer, Nave 8 - Pol. Ind. LA MASIA  
08798 Sant Cugat Sesgarrigues (Barcelona) Spain  
Phone: +34 93 8970268  
E-Mail: vb.espana@keb.de Web: keb-automation.com

**Switzerland** | KEB Automation AG  
Barzloostrasse 1 8330 Pfäeffikon/ZH Switzerland  
Phone: +41 43 2886060  
E-Mail: info@keb.ch Web: keb-automation.com

**United Kingdom** | KEB (UK) Ltd.  
5 Morris Close Park Farm Industrial Estate  
Wellingborough, Northants, NN8 6XF United Kingdom  
Phone: +44 1933 402220 Fax: +44 1933 400724  
E-Mail: info@keb.co.uk Web: keb-automation.com

**United States** | KEB America, Inc.  
5100 Valley Industrial Blvd. South  
Shakopee, MN 55379 United States  
Phone: +1 952 2241400 Fax: +1 952 2241499  
E-Mail: info@kebameric.com Web: kebameric.com



KEB'S GLOBAL PARTNER NETWORK



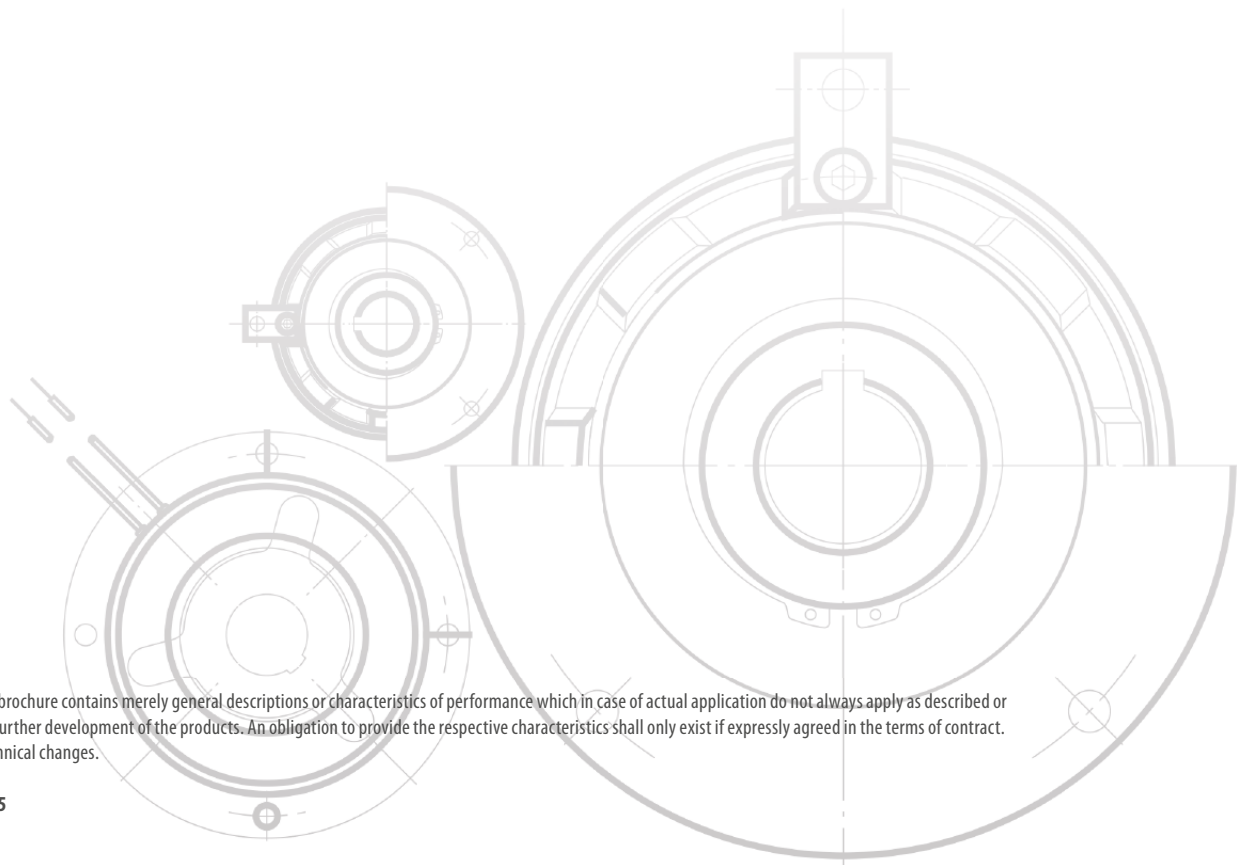

The information provided in this brochure contains merely general descriptions or characteristics of performance which in case of actual application do not always apply as described or which may change as a result of further development of the products. An obligation to provide the respective characteristics shall only exist if expressly agreed in the terms of contract. We reserve the right to make technical changes.

© KEB 0000005MAG 01.2025

**Automation with Drive**

**keb-automation.com**

KEB Automation KG Südstraße 38 32683 Barntrup Germany Phone +49 5263 401-0 E-Mail: info@keb.de