



COMBIVERT F6

INSTRUCTIONS FOR USE | **INSTALLATION F6 HOUSING 3**
PEAK POWER

Translation of the original manual
Document 20369912 EN 04



Preface

The hardware and software described in this document are products of KEB. The information contained in this document is valid at the time of publishing. KEB reserves the right to update this document in response to misprints, mistakes or technical changes.

Signal words and symbols

Certain procedures within this document can cause safety hazards during the installation or operation of the device. Refer to the safety warnings in this document when performing these procedures. Safety signs are also located on the device where applicable. A safety warning is marked by one of the following warning signs:

DANGER	Dangerous situation, which will cause death or serious injury if this safety warning is ignored.
WARNING	Dangerous situation, which may cause death or serious injury if this safety warning is ignored.
CAUTION	Dangerous situation, which may cause minor injury if this safety warning is ignored.
NOTICE	Situation, which can cause damage to property if this safety warning is ignored.

RESTRICTION

Used when the following statements depend on certain conditions or are only valid for certain ranges of values.



Used for informational messages or recommended procedures.

More symbols

- ▶ This arrow starts an action step.
- / - Enumerations are marked with dots or indents.
- => Cross reference to another chapter or another page.



Note to further documentation.
<https://www.keb-automation.com/search>



Laws and guidelines

KEB Automation KG confirms with the EC declaration of conformity and the CE mark on the device nameplate that it complies with the essential safety requirements.

The EC declaration of conformity can be downloaded on demand via our website.

Warranty and liability

The warranty and liability on design, material or workmanship for the acquired device is given in the general sales conditions.



Here you will find our general sales conditions.

<https://www.keb-automation.com/terms-conditions>



Further agreements or specifications require a written confirmation.

Support

Although multiple applications are referenced, not every case has been taking into account. If you require further information or if problems occur which are not referenced in the documentation, you can request the necessary information via the local KEB agency.

The use of our units in the target products is outside of our control and therefore lies exclusively in the area of responsibility of the customer.

The information contained in the technical documentation, as well as any user-specific advice in spoken and written and through tests, are made to best of our knowledge and information about the intended use. However, they are regarded as being only informal and changes are expressly reserved, in particular due to technical changes. This also applies to any violation of industrial property rights of a third-party. Selection of our units in view of their suitability for the intended use must be done generally by the user.

Tests can only be done within the intended end use of the product (application) by the customer. They must be repeated, even if only parts of hardware, software or the unit adjustment are modified.

Copyright

The customer may use the instructions for use as well as further documents or parts from it for internal purposes. Copyrights are with KEB and remain valid in its entirety.

This KEB product or parts thereof may contain third-party software, including free and/or open source software. If applicable, the license terms of this software are contained in the instructions for use. The instructions for use are already available to you, can be downloaded free of charge from the KEB website or can be requested from the respective KEB contact person.

Other wordmarks or/and logos are trademarks (™) or registered trademarks (®) of their respective owners.

Table of Contents

Preface	3
Signal words and symbols	3
More symbols.....	3
Laws and guidelines.....	4
Warranty and liability.....	4
Support	4
Copyright.....	4
Table of Contents	5
1 Basic Safety Instructions	9
1.1 Target group	9
1.2 Transport, storage and proper use	10
1.3 Installation	11
1.4 Electrical connection	12
1.4.1 EMC-compatible installation.....	13
1.4.2 Voltage test.....	13
1.4.3 Insulation measurement.....	13
1.5 Start-up and operation	14
1.6 Maintenance	16
1.7 Repair	16
1.8 Disposal	17
2 Product Description	18
2.1 Specified application	18
2.1.1 Residual risks	18
2.2 Unintended use	18
2.3 Product features	19
2.4 Part code	20
2.5 Nameplate	22
2.5.1 Configurable options	23
3 Technical data	24
3.1 Operating conditions	24
3.1.1 Climatic environmental conditions.....	24
3.1.2 Mechanical environmental conditions	25
3.1.3 Further environmental operating conditions.....	25
3.1.4 Electrical operating conditions.....	26
3.1.4.1 Device classification	26
3.1.4.2 Electromagnetic compatibility.....	26
3.2 Technical data of 230 V peak power devices	27
3.2.1 Overview of the 230 V peak power devices.....	27

3.2.2	Voltage and frequencies for 230V devices	28
3.2.2.1	Example of the calculation of the possible motor voltage 230V	29
3.2.3	Input and output currents / overload for 230 V devices.....	29
3.2.3.1	Overload characteristic (OL) for 230 V devices.....	30
3.2.3.2	Frequency-dependent maximum current (OL2) for 230 V peak power devices.....	32
3.2.4	Power dissipation at rated operation of the 230 V peak power devices.....	34
3.2.5	Fusing of the 230V devices	34
3.2.5.1	Fuse protection for AC supply	34
3.3	Technical data of 400 V peak power devices	35
3.3.1	Overview of the 400 V peak power devices.....	35
3.3.2	Voltage and frequencies for 400V devices	36
3.3.2.1	Example of the calculation of the possible motor voltage:	37
3.3.3	Input and output currents / overload for 400 V devices.....	37
3.3.3.1	Overload characteristic (OL) for 400 V devices.....	38
3.3.3.2	Frequency-dependent maximum current (OL2) for 400 V Peak Power devices.....	40
3.3.4	Overview of rectifier data for 400 V appliances.....	41
3.3.5	Power dissipation at rated operation of the 400 V Peak Power devices.....	42
3.3.6	Fusing of the 400V devices.....	42
3.3.6.1	Fuse protection for 400V AC supply.....	42
3.3.6.2	Protection of 400 V devices with DC power supply.....	43
3.3.6.3	Motor protection switch / circuit breaker.....	44
3.4	General electrical data	45
3.4.1	Switching frequency and temperature.....	45
3.4.1.1	Switching frequency and temperature of the 230 V peak power devices.....	45
3.4.1.2	Switching frequency and temperature of the 400 V peak power devices.....	45
3.4.2	DC link / braking transistor function.....	46
3.4.2.1	DC link / braking transistor function of the 230V peak power devices.....	47
3.4.2.2	DC link / braking transistor function of the 400V peak power devices.....	48
3.4.3	Fan	48
3.4.3.1	Switching behaviour of the fans	49
3.4.3.2	Switching points of the fans.....	49
4	Installation.....	50
4.1	Dimensions and weights	50
4.1.1	Built-in version air cooler	50
4.1.2	Push-through version air cooler IP20, IP54-ready	51
4.2	Control cabinet installation	52
4.2.1	Mounting instructions	52
4.2.2	Mounting distances	53
4.2.3	Installation of IP54-ready devices	54
4.2.4	Control cabinet ventilation.....	55
4.2.5	Airflow of the drive controller	55

5	Installation and connection	56
5.1	Overview of the COMBIVERT F6.....	56
5.2	Connection of the power unit.....	59
5.2.1	Connection of the voltage supply	59
5.2.1.1	Terminal block X1A.....	60
5.2.2	Protective earth and functional earth.....	61
5.2.2.1	Protective earth	61
5.2.2.2	Functional earthing.....	61
5.3	Mains connection	62
5.3.1	Supply cable.....	62
5.3.2	AC mains connection.....	62
5.3.2.1	AC supply 3-phase	62
5.3.2.2	Note on hard power systems.....	63
5.3.3	DC mains connection	64
5.3.3.1	Terminal block X1A DC connection	64
5.3.3.2	Connection at DC voltage supply	65
5.3.4	Connection of the motor	66
5.3.4.1	Wiring of the motor	66
5.3.4.2	Terminal block X1A motor connection	67
5.3.4.3	Selection of the motor line.....	68
5.3.4.4	Motor cable length and conducted interferences at AC supply	68
5.3.4.5	Motor cable length for parallel operation of motors	69
5.3.4.6	Motor cable cross-section	69
5.3.4.7	Interconnection of the motor.....	69
5.3.4.8	Connection of the temperature monitoring and brake control (X1C).....	70
5.3.5	Connection and use of a braking resistor.....	72
5.3.5.1	Terminal block X1A connection braking resistor.....	73
5.3.5.2	Use of intrinsically safe braking resistors	74
5.3.5.3	Use of non-intrinsically safe braking resistors.....	74
5.3.6	DC-bus connection.....	75
5.4	Accessories	77
5.4.1	Filters and chokes	77
5.4.2	Seal for IP54-ready devices	77
5.4.3	Mounting kit shield connection brackets.....	77
5.4.4	Side-mounted braking resistors.....	78
6	Approvals and certifications	79
6.1	CE-Marking.....	79
6.2	UL certification	80
6.3	Further informations and documentation	82

7 Revision history.....	83
Glossary	84
List of Figures.....	86
List of Tables.....	87

1 Basic Safety Instructions

The products are designed and constructed in accordance with state-of-the-art technology and the recognized safety rules and regulations. However, the use of such devices may cause functional hazards for life and limb of the user or third parties, or damages to the system and other material property.

The following safety instructions have been created by the manufacturer for the area of electric drive technology. They can be supplemented by local, country- or application-specific safety instructions. This list is not exhaustive. Violation of the safety instructions by the customer, user or other third party leads to the loss of all resulting claims against the manufacturer.

NOTICE



Hazards and risks through ignorance!

- ▶ Read the instructions for use!
- ▶ Observe the safety and warning instructions!
- ▶ If anything is unclear, please contact KEB Automation KG!

1.1 Target group

This instruction manual is determined exclusively for electrical personnel. Electrical personnel for the purpose of this instruction manual must have the following qualifications:

- Knowledge and understanding of the safety instructions.
- Skills for installation and assembly.
- Start-up and operation of the product.
- Understanding of the function in the used machine.
- Detection of hazards and risks of the electrical drive technology.
- Knowledge of *VDE 0100*.
- Knowledge of national safety regulations.
-

⚠ DANGER



Interventions by unauthorized personnel!

Danger to life by electric shock and malfunction!

- ▶ Modification or repair is only permitted by KEB authorised personnel.

1.2 Transport, storage and proper use

The transport is carried out by qualified persons in accordance with the environmental conditions specified in this manual. Drive controller shall be protected against excessive strains.



Transport of drive controllers with an edge length >75 cm

The transport by forklift without suitable tools can cause a deflection of the heat sink. This leads to premature aging or destruction of internal components.

- ▶ Transport of drive controllers on suitable pallets.
 - ▶ Do not stack drive controllers or burden them with other heavy objects.
-

NOTICE

Damage to the coolant connections

Bending of the tubes!

- ▶ Never place the device on the coolant connections
-

NOTICE

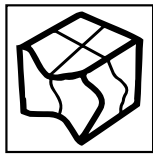

Behaviour in case of transport damage

- ▶ When receiving goods, check the device for transport damage such as deformations or loose parts.
 - ▶ In case of damage, contact the carrier immediately.
 - ▶ Do not operate the device in case of transport damage!
-



Drive controllers contain electrostatic sensitive components.

- ▶ Avoid contact.
 - ▶ Wear ESD-protective clothing.
-

Do not store drive controllers

- in the environment of aggressive and/or conductive liquids or gases.
- with direct sunlight.
- outside the specified environmental conditions.

1.3 Installation

⚠ DANGER**Do not operate in an explosive environment!**

- ▶ The product is not intended for the use in potentially explosive environment.

⚠ CAUTION**Design-related edges and high weight!****Contusions and bruises!**

- ▶ Never stand under suspended loads.
- ▶ Wear safety shoes.
- ▶ Secure drive controller accordingly when using lifting gear.

To prevent damages to the device:

- Make sure that no components are bent and/or isolation distances are changed.
- The device must not be put into operation in case of mechanical defects.
- Do not allow moisture or mist to penetrate the unit.
- Avoid dust permeating the device. Allow for sufficient heat dissipation if installed in a dust-proof housing.
- Note installation position and minimum distances to surrounding elements. Do not cover the ventilation openings.
- Mount the drive controller according to the specified degree of protection.
- Make sure that no small parts fall into the product during assembly and wiring (drilling chips, screws etc.). This also applies to mechanical components, which can lose small parts during operation.
- Check the reliable fit of the device connections in order to avoid contact resistances and sparking.
- Do not walk-on drive controller.
- Follow all safety instructions!

1.4 Electrical connection

⚠ DANGER**Voltage at the terminals and in the device !****Danger to life due to electric shock !**

- ▶ Never work on the open device or never touch exposed parts.
- ▶ For any work on the unit switch off the supply voltage, secure it against switching on and check absence of voltage by measuring at the input terminals.
- ▶ Wait until all drives has been stopped in order that no regenerative energy can be generated.
- ▶ Await capacitor discharge time (5 minutes). Check absence of voltage by measuring at the DC terminals.
- ▶ If personal protection is required, install suitable protective devices for drive converters.
- ▶ Never bridge upstream protective devices (even for testing purposes).
- ▶ Connect the protective earth conductor always to drive converter and motor.
- ▶ Install all required covers and protective devices for operation.
- ▶ The control cabinet shall be kept closed during operation.
- ▶ Residual current: This product may cause a dc current in the protective earth conductor. When a residual current protective device (RCD) or a residual current monitoring device (RCM) is used for the protection against direct or indirect contact, only a RCD or RCM type B is permitted on the power supply side of this product.
- ▶ Drive converters with a leakage current $> 3.5\text{mA AC}$ current (10mA DC current) are intended for a stationary connection. Protective earth conductors must be designed in accordance with the local regulations for equipment with high leakage currents according to *EN 61800-5-1*, *EN 60204-1* or *VDE 0100*.



If personnel protection is required during installation of the system, suitable protective devices must be used for drive controllers.

www.keb.de/fileadmin/media/Techinfo/dr/tn/ti_dr_tn-rcd-00008_en.pdf



Installations which include drive controller shall be equipped with additional control and protective devices in accordance with the relevant applicable safety requirements, e.g. act respecting technical equipment, accident prevention rules etc. They must always be complied with, also for drive controller bearing a CE marking.

For a trouble-free and safe operation, please pay attention to the following instructions:

- The electrical installation shall be carried out in accordance with the relevant requirements.
- Cable cross-sections and fuses must be dimensioned by the user according to the specified minimum/maximum values for the application.
- Connection of the drive converter is only permissible on symmetrical networks with a maximum line voltage (L1, L2, L3) with respect to earth (N/PE) of max. 300 V, USA UL: 480 / 277 V. An isolating transformer must be used for supply networks which exceed this value! In case of non-compliance the control is not longer considered to be a PELV circuit.
- With existing or newly wired circuits the person installing the units or machines must ensure that the PELV requirements are met.
- For drive converters that are not isolated from the supply circuit (in accordance with [EN 60721-3-2](#)) all control lines must be included in other protective measures (e.g. double insulation or shielded, earthed and insulated).
- When using components without isolated inputs/outputs, it is necessary that equipotential bonding exists between the components to be connected (e.g. by the equipotential line). Disregard can cause destruction of the components by equalizing currents.

1.4.1 EMC-compatible installation

Observance of the limit values required by EMC law is the responsibility of the customer.



Notes on EMC-compatible installation can be found here.
www.keb.de/fileadmin/media/Manuals/dr/emv/0000neb0000.pdf



1.4.2 Voltage test

Testing with AC voltage (in accordance with [EN 60204-1](#) chapter 18.4) may not be executed, since there is danger for the power semiconductors in the drive controller.



Due to the radio interference suppression capacitors, the test generator will switch off immediately with a current fault.



According to [EN 60204-1](#) it is permissible to disconnect already tested components. Drive controllers of the KEB Automation KG are delivered ex works voltage tested to 100% according to product standard.

1.4.3 Insulation measurement

An insulation measurement (in accordance with [EN 60204-1](#) chapter 18.3) with DC 500 V is permissible, if all power unit connections (grid-connected potential) and all control connections are bridged with PE. The insulation resistance of the respective device can be found in the technical data.

1.5 Start-up and operation

The start-up (i.e. for the specified application) is forbidden until it is determined that the installation complies with the machine directive; account is to be taken of [EN 60204-1](#).

⚠ WARNING

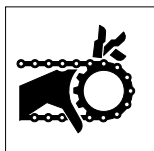

Software protection and programming!

Hazards caused by unintentional behavior of the drive!

- ▶ Check especially during initial start-up or replacement of the drive controller if parameterization is compatible to application.
- ▶ Securing a unit solely with software-supported functions is not sufficient. It is imperative to install external protective measures (e.g. limit switch) that are independent of the drive controller.
- ▶ Secure motors against automatic restart.

⚠ CAUTION



High temperatures at heat sink and coolant!

Burning of the skin!

- ▶ Cover hot surfaces safe-to-touch.
- ▶ If necessary, attach warning signs on the system.
- ▶ Before touching, check the surface and coolant lines.
- ▶ Before working let the unit cool down.

- During operation, all covers and doors shall be kept closed.
- Use only approved accessories for this device.
- Never touch terminals, busbars or cable ends.

⚠ WARNING



Triggering of overcurrent protection devices

Risk of fire or electric shock!

- ▶ Triggering of an overcurrent protection device will be a hint for an overload or short circuit. Triggering a RCD may be caused by a leakage current.
- ▶ In order to reduce the risk of fire or electric shock, live parts and other components of the controller should be checked and replaced in case of damage.
- ▶ If the contacts of an overload relay are burned, the complete relay must be replaced.

⚠ CAUTION

High sound level during operation!

Hearing damage possible!

- ▶ Wear hearing protection!

NOTICE

Continuous operation (S1) with load > 60% or from a rated motor power of 55kW!

Premature ageing of the electrolytic capacitors!

- ▶ Mains choke with $U_k = 4\%$ absolutely necessary.



If a drive controller with electrolytic capacitors in a DC link has not been in operation for more than one year, observe the following instructions.

www.keb.de/fileadmin/media/Techinfo/dr/tn/ti_dr_tn-format-capacitors-00009_en.pdf

**Switching at the output**

Switching between motor and drive controller is prohibited for single drives during operation as this may trigger the protection gear of the device. Function 'speed search' must be activated if switching can not be avoided. Speed search may only be triggered after closing the motor contactor (e.g. by switching the control release).

Connecting and disconnecting is permissible with multiple motor drives if at least 1 motor is running during the switch-over process. The drive controller must be dimensioned to the occurring starting currents.

The 'speed search' function must be activated if the motor is still running during a restart of the drive controller (mains on) (e.g. due to large rotating masses).

Switching at the input

For applications that require cyclic switching off and on of the drive controller, maintain an off-time of at least 5 min after the last switch on. If you require shorter cycle times please contact KEB Automation KG.

Short-circuit resistance

The drive converters are conditional short-circuit proof. After resetting the internal protection devices, the function as directed is guaranteed.

Exceptions:

- If an earth-leakage fault or short-circuit often occurs at the output, this can lead to a defect in the unit.
- If a short-circuit occurs during regenerative operation (2nd or 4th quadrant, regeneration into the DC link), this can lead to a defect in the unit.

1.6 Maintenance

The following maintenance work has to be carried out when required, but at least once per year by authorized and trained personnel. Check unit for loose screws and plugs and tighten if necessary.

- ▶ Check system for loose screws and plugs and tighten if necessary.
- ▶ Clean drive controller from dirt and dust deposits. Pay attention especially to cooling fins and protective grid of the fans.
- ▶ Examine and clean extracted air filter and cooling air filter of the control cabinet.
- ▶ Check the function of the fans of the drive controller. The fan must be replaced in case of audible vibrations or squeak.
- ▶ In the case of liquid-cooled drive controllers a visual test of the cooling circuit for leaks and corrosion must be carried out. The cooling circuit must be completely empty if a unit shall be switched off for a longer period. The cooling circuit must be blown out additionally with compressed air at temperatures below 0°C.

1.7 Repair

In case of malfunction, unusual noises or smells inform a person in charge!

⚠ DANGER



Unauthorized exchange, repair and modifications!

Unpredictable malfunctions!

- ▶ The function of the drive controller is dependent on its parameterization. Never replace without knowledge of the application.
- ▶ Modification or repair is permitted only by KEB Automation KG authorized personnel.
- ▶ Only use original manufacturer parts.
- ▶ Infringement will annul the liability for resulting consequences.

In case of failure, please contact the machine manufacturer. Only the machine manufacturer knows the parameterisation of the used drive controller and can provide an appropriate replacement or induce the maintenance.

1.8 Disposal

Electronic devices of the KEB Automation KG are exclusively professional devices for further industrial processing (so-called B2B devices).

Manufacturers of B2B devices are obliged to take back and recycle devices manufactured after 14.08.2018. These devices may not be disposed at the collection centres of public sector disposal organisations.

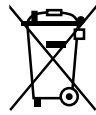

If no deviating agreement has been made between the customer and KEB or no deviating mandatory legal regulation exists, KEB products marked in this way can be returned. Company and keyword to the return point can be taken from the list below. Shipping costs are paid by the customer. Thereupon the devices will be professionally recycled and disposed.

The entry numbers are listed country-specific in the following table. The corresponding KEB return addresses can be found on our website.

Withdrawal by	WEEE-Reg.-No.	Keyword
Austria		
KEB Automation GmbH	ERA: 51976	Stichwort „Rücknahme WEEE“
France		
RÉCYLUM - Recycle point	ADEME: FR021806	Mots clés „KEB DEEE“
Germany		
KEB Automation KG	EAR: DE12653519	Stichwort „Rücknahme WEEE“
Italy		
COBAT	AEE: (IT) 19030000011216	Parola chiave „Ritiro RAEE“
Spain		
KEB Automation KG	RII-AEE 7427	Palabra clave „Retirada RAEE“
Česko		
KEB Automation KG	RETELA 09281/20 ECZ	Klíčové slovo: Zpětný odběr OEEZ
Slowakei		
KEB Automation KG	ASEKOL: RV22EEZ0000421	Klíčové slovo: "Spätný odber OEEZ"

The packaging must be feed to paper and cardboard recycling.

2 Product Description

The device series COMBIVERT F6 concerns to drive controllers, which are optimized for operation at synchronous and asynchronous motors.

The COMBIVERT can be extended with a safety module for the use in safety-oriented applications. The COMBIVERT F6 series are drive controllers with functional safety, optimized for operation at synchronous and asynchronous motors.

Various safety functions are available for different applications. It can be operated with a fieldbus module at different fieldbus systems. The control board has a system comprehensive operating concept.

The COMBIVERT complies with the requirements of the Machinery Directive. The possible functions are certified via a type test.

The COMBIVERT is a product of limited availability in accordance with [EN 61800-3](#). This product may cause radio interference in residential areas. In this case the operator may need to take corresponding measures.

The Machinery Directive, EMC Directive, Low Voltage Directive and other directives and regulations must be observed

2.1 Specified application

The COMBIVERT serves exclusively for the control and regulation of three-phase motors. It is intended for the installation into electrical systems or machines in the industrie.

Technical data and information for connection conditions shall be taken from the nameplate and from the instructions for use and must be strictly observed.

The used semiconductors and components of the KEB Automation KG are developed and dimensioned for the use in industrial products.

Restriction

If the product is used in machines, which work under exceptional conditions or if essential functions, life-supporting measures or an extraordinary safety step must be fulfilled, the necessary reliability and security must be ensured by the machine builder.

2.1.1 Residual risks

Despite intended use, the drive controller can reach unexpected operating conditions in case of error, with wrong parameterization, by faulty connection or unprofessional interventions and repairs. This can be:

- wrong direction of rotation
- motor speed too high
- motor is running into limitation
- motor can be under voltage even in standstill
- automatic start

2.2 Unintended use

The operation of other electric consumers is prohibited and can lead to the destruction of the devices. The operation of our products outside the indicated limit values of the technical data leads to the loss of any liability claims.

2.3 Product features

These instructions for use describe the power units of the following devices:

Device type:	Drive controller
Series:	COMBIVERT F6
Power range:	18.5 kW / 400V 11 kW / 230V
Housing:	3 Peak Power

The COMBIVERT F6 is characterized by the following features:

- Operation of three-phase asynchronous motors and three-phase synchronous motors, in operating modes open-loop or closed-loop with and without speed feedback
- Following fieldbus systems are supported:
EtherCAT, VARAN, PROFINET, POWERLINK or CAN
- System-overlapping operating concept
- Wide operating temperature range
- Low switching losses by IGBT power unit
- Low noise development due to high switching frequencies
- Different heat sink concepts
- Temperature-controlled fan, easily replaceable
- Torque limits and s-curves are adjustable to protect gearboxes
- General protection functions of the COMBIVERT series against overcurrent, over-voltage, ground fault and overtemperature
- Analog inputs and outputs, digital inputs and outputs, relay output (potential-free), brake control and -supply, motor protection by I²t, KTY- or PTC input, two encoder interfaces, diagnostic interface, fieldbus interface (depending on the control board)
- Integrated safety function according to [EN 61800-5-2](#)

2.4 Part code

xx F6 xx-x-xx-xx

Heat sink version

1: Air-cooler, mounted version
2: Liquid cooler (water), mounted version
3: Air-cooler, through-mount version IP54-ready
4: Liquid cooler (water), through-mount version IP54-ready
5: Air-cooler, through-mount version IP20
6: Liquid cooler (water), trough-mount version IP54-ready, sub-mounted braking resistors
7: Liquid cooler (oil), through-mount version IP54-ready
9: Liquid cooler (water), mounted version, sub-mounted braking resistors
A: Liquid cooler (water), mounted version, High Performance, sub-mounted braking resistors
B: Liquid cooler (water), through-mount version, IP54-ready, High Performance, sub-mounted braking resistors
C: Air-cooler, mounted version, Version 2
D: Air-cooler, mounted version, High-Performance
E: Liquid cooler (water), mounted version, High-Performance
F: Air-cooler, through-mount version IP54-ready, High-Performance
G: Liquid cooler (water), trough-mount version IP54-ready, High-Performance
H: Air-cooler,, Convektion, trough-mount version IP54-ready

Control board variant

APPLIKATION
1: Multi Encoder Interface, CAN ^{® 2)} , Real-Time Ethernet-busmodule ³⁾
B Multi Encoder Interface, CAN ^{® 2)} , Real-Time Ethernet-busmodule ³⁾ , Alternative connector
KOMPAKT
1: Multi Encoder Interface, CAN ^{® 2)} , STO, EtherCAT ^{® 1)}
2: Multi Encoder Interface, CAN ^{® 2)} , STO, VARAN
PRO
0: No Encoder, CAN ^{® 2)} , Real-Time Ethernetinterface ³⁾
1: Multi Encoder Interface, CAN ^{® 2)} , Real-Time Ethernet interface ³⁾
3: Multi Encoder Interface, CAN ^{® 2)} , Real-Time Ethernet interface ³⁾ , RS485-potential free
4: No Encoder, CAN ^{® 2)} , Real-Time Ethernetinterface ³⁾ , safe relay
5: Multi Encoder Interface, CAN ^{® 2)} , Real-Time Ethernet interface ³⁾ , safety relay
B: Multi Encoder Interface, CAN ^{® 2)} , Real-Time Ethernet interface ³⁾ , alternative connector

continued on the next page

x x	F 6	x	x	x	-x	x	x	x
		Switching frequency, Software current limit, Turn-off current		0: 2 kHz / 125% / 150%	8: 2 kHz / 180% / 216%			
				1: 4 kHz / 125% / 150%	9: 4 kHz / 180% / 216%			
				2: 8 kHz / 125% / 150%	A: 8 kHz / 180% / 216%			
				3: 16 kHz / 125% / 150%	B: 8 kHz / HSD			
				4: 2 kHz / 150% / 180%	C: 6 kHz / HSD			
				5: 4 kHz / 150% / 180%	Non standard switching		D: frequency / Overload characteristic	
				6: 8 kHz / 150% / 180%	E: Special Device			
				7: 16 kHz / 150% / 180%				
		Voltage / Connection type		1: 3ph 230 V AC/DC with braking transistor				
				2: 3ph 230 V AC/DC without braking transistor				
				3: 3ph 400 V AC/DC with braking transistor				
				4: 3ph 400 V AC/DC without braking transistor				
				A: 3ph 400 V AC/DC incl. GTR7 / max. rectifier / max. pre-charging				
				B: 3ph 400 V AC/DC without GTR7 / max. rectifier / max. pre-charging				
				C: 3ph 400 V AC/DC. GTR7-variant 2				
				D: 3ph 400 V AC/DC GTR7-variant 2 / max. rectifier / max. pre-charging				
		Housing		2...9				
		Equipment		1: Safety module type 1 /STO at control type K				
				3: Safety module type 3				
				4: Safety module type 4				
				5: Safety module type 5				
		Control type		A: APPLICATION				
				K: COMPACT				
				P: PRO				
		Series		COMBIVERT F6				
		Inverter size		10...33				

Table 1: Part code

- 1) EtherCAT® is registered trademark and patented technology, licensed by Beckhoff Automation GmbH, Germany
- 2) CANopen® is registered trademark of CAN in AUTOMATION - International Users and Manufacturers Group e.V.
- 3) The Real-Time Ethernetbusmodul / Real-Time Ethernet interface contains various fieldbus control types which can be adjusted by software (parameter fb68)



The part code may not be used as order code, but only for identification!

2.5 Nameplate

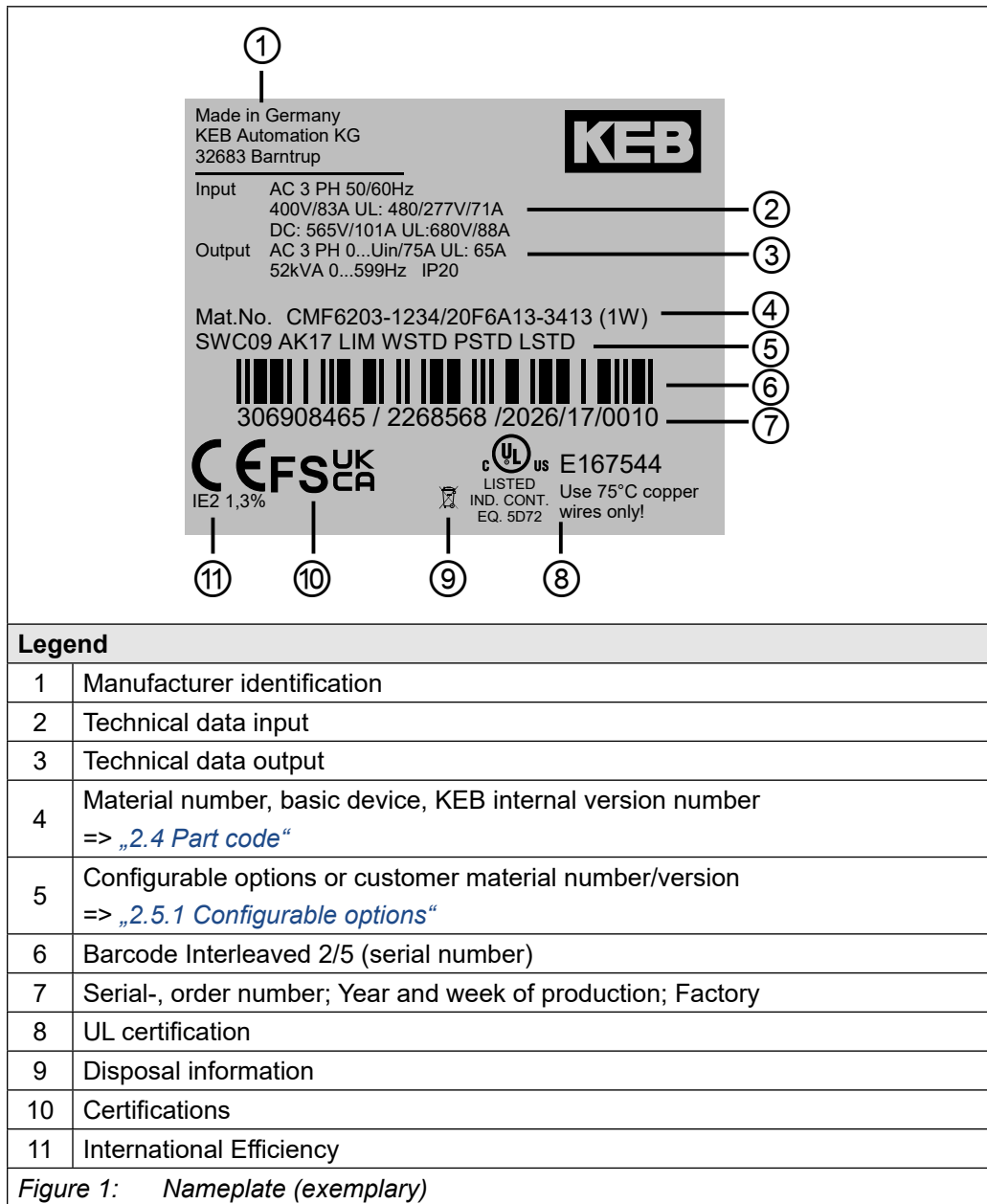

2.5.1 Configurable options

Features	Feature values	Description
Software	SWxxx ¹⁾	Software status of the drive controller
Accessories	Axxx ¹⁾	Selected accessories
	NAK	No accessories
Output frequency activation	LIM	Limitation to 599 Hz
	ULO	> 599 Hz activated
Warranty	WSTD	Warranty - Standard
	Wxxx ¹⁾	Warranty extension
Parameterization	PSTD	Parameterization - Standard
	Pxxx ¹⁾	Parameterization - Customer-specific
Nameplate logo	LSTD	Logo - Standard
	Lxxx ¹⁾	Logo - Customer-specific
<i>Figure 2: Configurable options</i>		

¹⁾ „x“ indicates a variable value

3 Technical data

Unless otherwise indicated, all electrical data in the following chapter refer to a 3-phase AC mains.

3.1 Operating conditions

3.1.1 Climatic environmental conditions

Storage		Standard	Class	Descriptions
Ambient temperature		EN 60721-3-1	1K4	-25...55 °C
Relative humidity		EN 60721-3-1	1K3	5...95 % (without condensation)
Storage height		–	–	Max. 3000 m above sea level
Transport		Standard	Class	Descriptions
Ambient temperature		EN 60721-3-2	2K3	-25...70 °C
Relative humidity		EN 60721-3-2	2K3	95 % at 40 °C (without condensation)
Operation		Standard	Class	Descriptions
Ambient temperature		EN 60721-3-3	3K3	5...40 °C (extended to -10...45 °C)
Coolant inlet temperature	Air	–	–	5...40 °C (extended to -10...45 °C)
Relative humidity		EN 60721-3-3	3K3	5...85 % (without condensation)
Version and degree of protection		EN 60529	IP20	Protection against foreign material > ø12.5 mm No protection against water Non-conductive pollution, occasional condensation when PDS is out of service. Drive controller generally, except power connections and fan unit (IPxxA)
Site altitude		–	–	Max. 2000 m above sea level • With site altitudes over 1000 m a derating of 1 % per 100 m must be taken into consideration. • With site altitudes over 2000 m, the control board to the mains has only basic isolation. Additional measures must be taken when wiring the control.

Table 2: Climatic environmental conditions

3.1.2 Mechanical environmental conditions

Storage	Standard	Class	Descriptions
Vibration limits	EN 60721-3-1	1M2	Vibration amplitude 1.5 mm (2...9 Hz) Acceleration amplitude 5 m/s ² (9...200 Hz)
Shock limit values	EN 60721-3-1	1M2	40 m/s ² ; 22 ms
Transport	Standard	Class	Descriptions
Vibration limits	EN 60721-3-2	2M1	Vibration amplitude 3.5 mm (2...9 Hz) Acceleration amplitude 10 m/s ² (9...200 Hz)
Shock limit values	EN 60721-3-2	2M1	100 m/s ² ; 11 ms
Operation	Standard	Class	Descriptions
Vibration limits	EN 60721-3-3	3M4	Vibration amplitude 3.0 mm (2...9 Hz) Acceleration amplitude 10 m/s ² (9...200 Hz)
	EN 61800-5-1	–	Vibration amplitude 0.075 mm (10...58 Hz) Acceleration amplitude 10 m/s ² (58...150 Hz)
Shock limit values	EN 60721-3-3	3M4	100 m/s ² ; 11 ms

Table 3: Mechanical environmental conditions

3.1.3 Further environmental operating conditions

Operation	Standard	Class	Descriptions
Chemically active substances	EN 60721-3-3	3C2	No salt spray
Mechanically active substances		3S2	–
Organic		3B1	–
UV resistance	EN 61800-5-1	–	No requirement

Table 4: Further environmental operating conditions

3.1.4 Electrical operating conditions

3.1.4.1 Device classification

Requirement	Standard	Class	Descriptions
Overtoltage category	EN 61800-5-1	III	–
Pollution degree	EN 61800-5-1	2	Non-conductive pollution, occasional condensation when PDS is out of service

Table 5: Device classification

3.1.4.2 Electromagnetic compatibility

For devices without an internal filter, an external filter is required to comply with the following limits.

EMC emitted interference	Standard	Class	Descriptions
Conducted interference emission	EN 61800-3	C2 / C3	The specified value is only maintained in connection with a filter. Information about interference suppression (rated switching frequency, max. motor cable length) can be found in the corresponding filter instructions..
Radiated emitted interference	EN 61800-3	C2	–
EMF	EN 61800-5-1	–	Table P.2
Immunity	Standard	Level	Descriptions
Static discharges	EN 61000-4-2	8 kV 4 kV	AD (air discharge) CD (contact discharge)
Burst - Ports for process measurement control lines and signal interfaces	EN 61000-4-4	2 kV	–
Burst - AC - Power ports	EN 61000-4-4	4 kV	–
Surge - Power ports	EN 61000-4-5	1 kV 2 kV	Phase-phase Phase-ground
Conducted immunity, induced by high-frequency fields	EN 61000-4-6	10 V	0.15...80 MHz
Electromagnetic fields	EN 61000-4-3	10 V/m 3 V/m 1 V/m	80 MHz...1 GHz 1.4...2 GHz 2...2.7 GHz
voltage dips	EN 61000-4-11 EN 61000-4-34	Class 3	–
frequency fluctuations	EN 61000-4-28	± 2 %	–
Voltage unbalances	EN 61000-2-4	≤ 3 %	–

Table 6: Electromagnetic compatibility

3.2 Technical data of 230 V peak power devices

3.2.1 Overview of the 230V peak power devices

The technical data are for 2/4-pole standard motors. With other pole numbers the drive controller must be dimensioned onto the rated motor current. Contact KEB for special or medium frequency motors.

Device size		15
Housing		3
Rated apparent output power	S_{out} / kVA	19
Max. rated motor power	¹⁾ P_{mot} / kW	11
Rated input voltage	U_N / V	230 (UL: 240)
Input voltage range	U_{in} / V	170...264
Mains phases		3
Mains frequency	f_N / Hz	50 / 60 ±2
Rated input current @ $U_N = 230$ V	I_{in} / A	57
Rated input current @ $U_N = 240$ V	I_{in_UL} / A	57
Insulation resistance @ $U_{dc} = 500$ V	R_{iso} / MΩ	> 20
Leakage current	I_{iso_ac} / mA	> 3.5
Output voltage	U_{out} / V	0... U_{in}
Output frequency	²⁾ f_{out} / Hz	0...599
Output phases		3
Rated output current @ $U_N = 230$ V	I_N / A	48
Rated output current @ $U_N = 240$ V	I_{N_UL} / A	48
Rated output overload (60 s)	³⁾⁴⁾ I_{60s} / %	200
Software current limit	³⁾ I_{lim} / %	225
Overcurrent	³⁾ I_{OC} / %	270
Rated switching frequency	f_{SN} / kHz	8
Max. switching frequency	⁵⁾ f_{S_max} / kHz	16
Power dissipation at rated operation	¹⁾ P_D / W	521
Overload current over time	³⁾ I_{OL} / %	„3.2.3.1 Overload characteristic (OL) for 230 V devices“
Maximum current 0Hz/50Hz at $f_s = 2$ kHz	I_{out_max} / %	206 / 270
Maximum current 0Hz/50Hz at $f_s = 4$ kHz	I_{out_max} / %	165 / 270
Maximum current 0Hz/50Hz at $f_s = 8$ kHz	I_{out_max} / %	113 / 265
Maximum current 0Hz/50Hz at $f_s = 16$ kHz	I_{out_max} / %	58 / 165
<i>continued on the next page</i>		

TECHNICAL DATA OF 230 V PEAK POWER DEVICES

Device size		15
Housing		3
Max. braking current	I_{B_max} / A	76
Min. braking resistor value	R_{B_min} / Ω	5,3
Braking transistor	⁶⁾	Max. cycle time: 120s; Max c.d.f.: 50%
Protective function for braking transistor		Short-circuit monitoring
Protection function braking transistor (Error GTR7 always on)	⁷⁾	Feedback signal evaluation and current shutdown
Max. motor cable length shielded	⁸⁾ // m	100

Table 7: Overview of the 230 V peak power device data

- ¹⁾ Rated operation corresponds to $U_N = 230V$, rated switching frequency, output frequency = 50 Hz (4-pole standard asynchronous motor).
- ²⁾ The output frequency is to be limited in such a way that it does not exceed 1/10 of the switching frequency. Notice! Devices with a maximum output frequency higher than 599Hz are subject to export restrictions.
- ³⁾ The values refer in % to the rated output current I_N .
- ⁴⁾ Observe limitations „3.2.3.1 Overload characteristic (OL) for 230 V devices“.
- ⁵⁾ A detailed description of the derating „3.4.1.1 Switching frequency and temperature of the 230 V peak power devices“.
- ⁶⁾ The cyclic duration factor is additionally limited by the used braking resistor.
- ⁷⁾ The feedback signal evaluation monitors the functionality of the braking transistor. The current is switched off via the internal mains input bridge of the AC supply.
- ⁸⁾ The maximum cable length depends on various factors. Further information can be found in the corresponding filter instructions.

3.2.2 Voltage and frequencies for 230V devices

Input voltages and frequencies		
Rated input voltage	U_N / V	230
Rated mains voltage (USA)	U_{N_UL} / V	240
Input voltage range	U_{IN} / V	170...264
Input phases		3
Mains frequency	f_N / Hz	50/60
Mains frequency tolerance	$\pm f_N / Hz$	2

Table 8: Input voltages and frequencies of the 230V devices

DC link voltage		
DC link rated voltage @ $U_N = 400V$	U_{N_dc} / V	325
DC link rated voltage @ $U_{N_UL} = 480V$	$U_{N_UL_dc} / V$	339
DC link voltage working voltage range	U_{IN_dc} / V	240...373

Table 9: DC link voltage for 230V devices

Output voltages and frequencies		
Output voltage at AC supply	¹⁾ U_{out} / V	0... U_{in}
Output frequency	²⁾ f_{out} / Hz	0...599
Output phase		3

Table 10: Output voltages and frequencies of the 230V devices

- ¹⁾ The voltage to the motor is dependent on the actual input voltage and the control method („3.2.2.1 Example of the calculation of the possible motor voltage 230V“).
- ²⁾ The output frequency is to be limited in such a way that it does not exceed 1/10 of the switching frequency. Devices with a maximum output frequency higher than 599Hz are restricted for export.

3.2.2.1 Example of the calculation of the possible motor voltage 230V

The motor voltage for dimensioning of the drive is depending on the used components. The motor voltage reduces according to the following table.

Component	Reduction / %	Example
Mains choke U_k	4	Example: Open-loop drive controller with mains- and motor choke at non-rigid supply system: 230 V mains voltage - 11 % = 204,7 V motor voltage
Drive controller open-loop	4	
Drive controller closed-loop	8	
Motor choke U_k	1	
Non-rigid supply system	2	

Table 11: Example of the calculation of the possible motor voltage 230V

3.2.3 Input and output currents / overload for 230 V devices

Device size		15
Rated input current @ $U_N = 230 V$	¹⁾ I_{in} / A	57
Rated input current @ $U_{N_UL} = 240 V$	¹⁾ I_{in_UL} / A	57
Rated output current @ $U_N = 230 V$	I_N / A	48
Rated output current @ $U_{N_UL} = 240 V$	I_{N_UL} / A	48
Rated output overload (60 s)	²⁾ $I_{60s} / \%$	200
Overload current	²⁾ $I_{OL} / \%$	=> „3.2.3.1 Overload characteristic (OL) for 230 V devices“
Software current limit	^{2) 3)} $I_{lim} / \%$	225
Overcurrent	²⁾ $I_{OC} / \%$	270

Table 12: Input and output currents of the 230 V peak power devices

- ¹⁾ The values resulting from rated operation with B6 rectifier circuit and mains choke 4% U_k .
- ¹⁾ The values refer in % to the rated output current I_N .
- ³⁾ Limitation of the current setpoint in closed-loop operation. This setpoint limit is not active in v/f operation.

3.2.3.1 Overload characteristic (OL) for 230 V devices

All drive controllers can be operated at rated switching frequency with an utilisation of 200 % for 60s.

The OL overload function is a root mean square (RMS) function.

The greater the difference between the overload and underload phases, the greater the deviation of the RMS from the arithmetic mean value.

For extreme overloads (=> „*Figure 3: Switch-off time t depending on the overload I/IN (OL) for 230 V devices*“), the load is weighted more heavily. This means the load is provided with a factor for the calculation of the RMS value, by way that the overload protection function triggers, even if the RMS value does not reach 100%.

Restrictions:

- The thermal design of the heat sink is based on the rated operation. The following values are taken into account: Rated output current, ambient temperature, rated switching frequency, rated voltage.
- At high ambient temperatures and/or high heat sink temperatures (for example, by preceding utilisation nearby 100%) the drive controller can change to overtemperature error before triggering the protective function OL.
- At low output frequencies or switching frequencies higher than the rated switching frequency, the frequency-dependent maximum current can be exceeded before and error OL2 can be triggered
=> „*3.2.3.2 Frequency-dependent maximum current (OL2) for 230 V peak power devices*“.

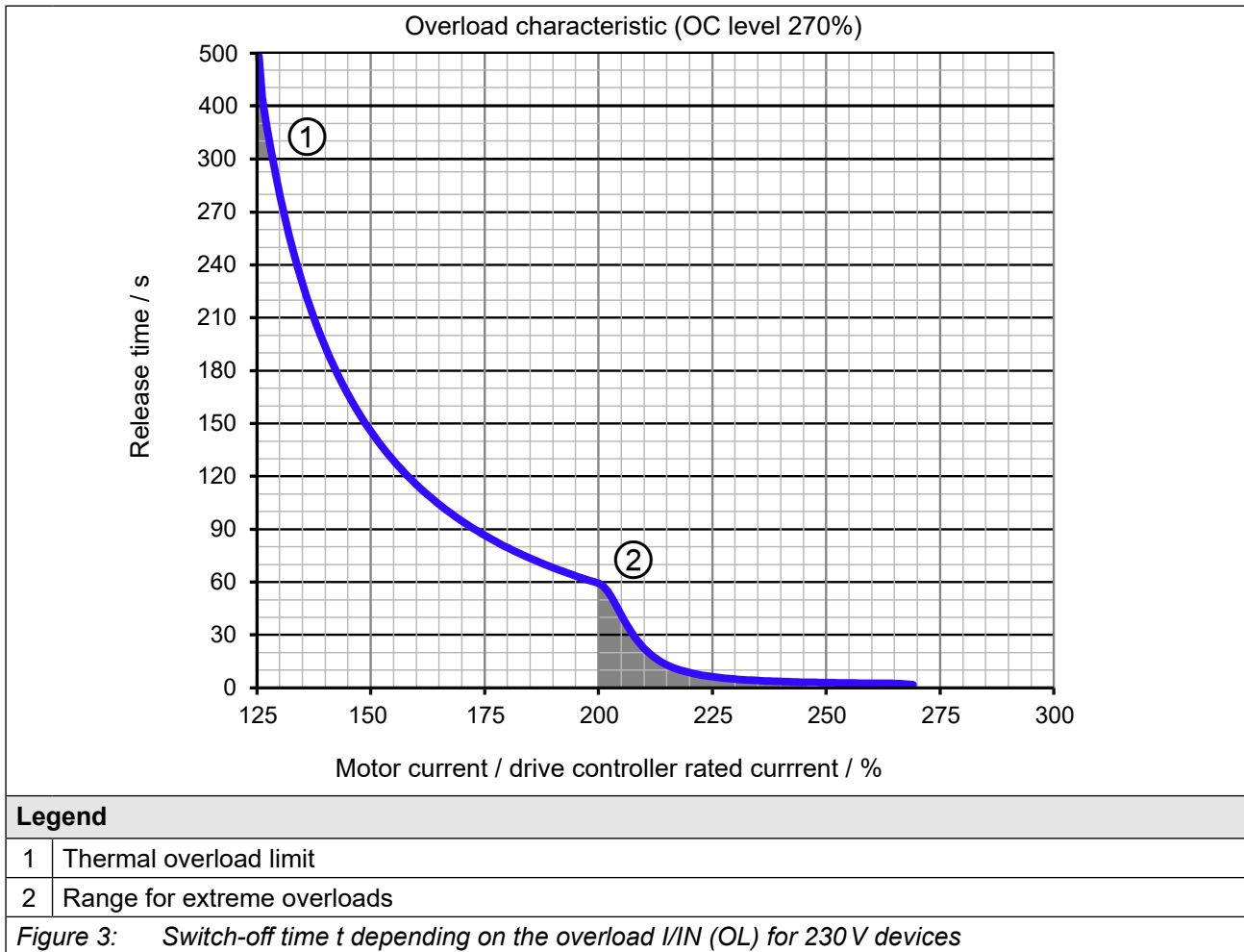

- On exceeding a load of 105 % the overload integrator starts.
- When falling below the integrator counts backwards.
- If the integrator reaches the overload characteristic "Error! overload (OL)" is triggered.

After a cooling down period, the integrator can be reset now. The drive controller must remain switched on during the cooling down phase.

Operation in the range of the thermal overload limit

Due to the high steepness of the overload characteristic, the duration of a permissible overload in this range ① cannot be determined exactly. Therefore, the design of the drive controller should be assumed to have a maximum overload time of 300s.

3.2.3.2 Frequency-dependent maximum current (OL2) for 230 V peak power devices

The characteristics of the maximum currents for a switching frequency which are depending on the output frequency are different for each drive controller, but the following rules are generally applicable:

- Applies for the rated switching frequency: At 0 Hz output frequency the drive controller can provide at least the rated output current.
- Lower maximum currents apply for switching frequencies > rated switching frequency.

If error (OL2) shall be triggered on exceeding the maximum currents or if the switching frequency is automatically reduced (derating) can be adjusted in the drive controller parameters.

The following characteristic curve indicates the permissible maximum current for the output frequency values 0 Hz, 3 Hz, 6 Hz, 10 Hz, 25 Hz and 50 Hz. Device size 15 is represented exemplary (with 4 kHz rated switching frequency).

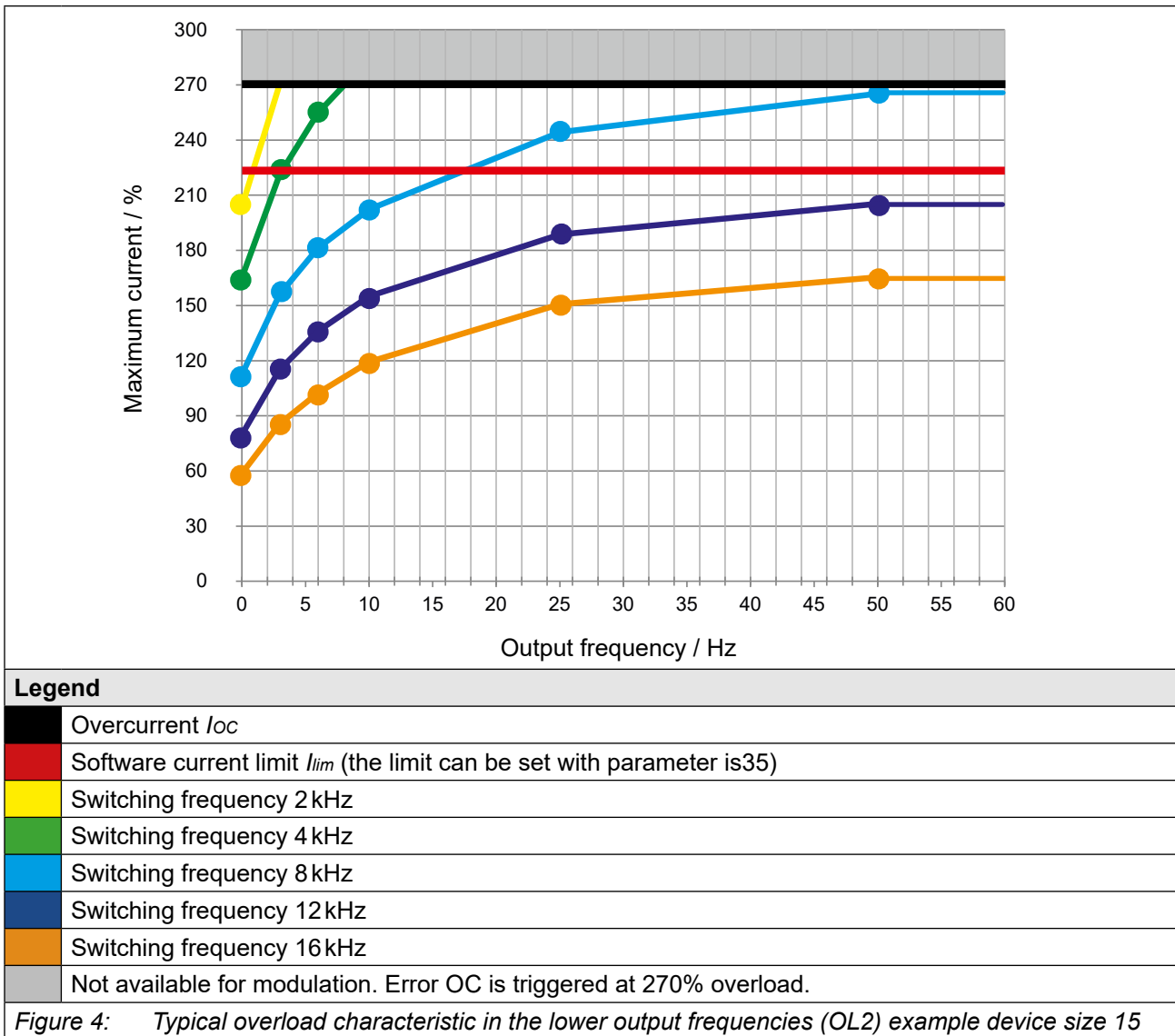

Figure 4: Typical overload characteristic in the lower output frequencies (OL2) example device size 15



The frequency-dependent maximum current I_{out_max} / % refers in % to the rated output current I_N .

The current remains constant from the last specified output frequency value.



The values for the respective device size are listed in the following tables.

Frequency-dependent maximum current

Device size		15					
Rated switching frequency		8					
Output frequency	f_{out} / Hz	0	3	6	10	25	50
Frequency-dependent maximum current @ f_s I_{out_max} % <i>Basic Time Period = 62.5 μs (Parameter is22=0)</i>	2 kHz	206	270	270	270	270	270
	4 kHz	165	221	254	270	270	270
	8 kHz	113	156	181	202	244	265
	16 kHz	58	85	102	119	150	165
Frequency-dependent maximum current @ f_s I_{out_max} % <i>Basic Time Period = 71.4 μs (Parameter is22=1)</i>	1.75 kHz	206	270	270	270	270	270
	3.5 kHz	175	234	270	270	270	270
	7 kHz	126	172	199	222	266	270
	14 kHz	69	100	118	137	169	184
Frequency-dependent maximum current @ f_s I_{out_max} % <i>Basic Time Period = 83.3 μs (Parameter is22=2)</i>	1.5 kHz	206	270	270	270	270	270
	3 kHz	185	247	270	270	270	270
	6 kHz	139	189	217	242	270	270
	12 kHz	79	115	135	154	187	204
Frequency-dependent maximum current @ f_s I_{out_max} % <i>Basic Time Period = 100 μs (Parameter is22=3)</i>	1.25 kHz	206	270	270	270	270	270
	2.5 kHz	196	260	270	270	270	270
	5 kHz	152	205	236	263	270	270
	10 kHz	96	135	158	178	216	234

Table 13: Frequency-dependent maximum current for device size 15

3.2.4 Power dissipation at rated operation of the 230 V peak power devices

Device size		15
Rated switching frequency	f_{SN} / kHz	8
Power dissipation at rated operation	¹⁾ P_D / W	521

Table 14: Power dissipation of the 230 V peak power devices

¹⁾ Rated operation corresponds to $U_N = 230\text{ V}$; $f_{SN} = 8\text{ kHz}$; I_N ; $f_N = 50\text{ Hz}$ (typically value)

3.2.5 Fusing of the 230V devices

3.2.5.1 Fuse protection for AC supply

Device size	Max. size of the fuse / A			
	$U_N = 230\text{ V}$ gG (IEC)	$U_N = 240\text{ V}$ class "J"	$U_N = 240\text{ V}$	
	SCCR 30 kA	SCCR 5 kA	SCCR 30 kA	Type
15	80	80	80	LITTELFUSE L25S080
			80	SIBA 20 189 20.80
			80	EATON 170M1366

Table 15: Fusings of the 230 V peak power devices



Short-circuit capacity

According to the requirements of EN 61439-1 and EN 61800-5-1, the following applies to connection to a power supply: The devices are suitable for use in a circuit capable of delivering not more than 30 kA eff. unaffected symmetrical short-circuit current.

3.3 Technical data of 400 V peak power devices

3.3.1 Overview of the 400 V peak power devices

The technical data are for 2/4-pole standard motors. With other pole numbers the drive controller must be dimensioned onto the rated motor current. Contact KEB for special or medium frequency motors.

Device size		17
Housing		3
Rated apparent output power	S_{out} / kVA	29
Max. rated motor power	¹⁾ P_{mot} / kW	18,5
Rated input voltage	U_N / V	400 (UL: 480 / 277)
Input voltage range	U_{in} / V	280...550
Mains phases		3
Mains frequency	f_N / Hz	50 / 60 ±2
Rated input current @ $U_N = 400$ V	I_{in} / A	54
Rated input current @ $U_N = 480$ V	I_{in_UL} / A	41
Insulation resistance @ $U_{dc} = 500$ V	R_{iso} / MΩ	> 20
Leakage current	I_{iso_ac} / mA	> 3.5
Output voltage	U_{out} / V	0... U_{in}
Output frequency	²⁾ f_{out} / HZ	0...599
Output phases		3
Rated output current @ $U_N = 400$ V	I_N / A	42
Rated output current @ $U_N = 480$ V	I_{N_UL} / A	31,5
Rated output overload (60 s)	³⁾⁴⁾ I_{60s} / %	150
Software current limit	³⁾ I_{lim} / %	180
Overcurrent	³⁾ I_{OC} / %	216
Rated switching frequency	f_{SN} / kHz	4 (S1 operation), 8 (S3 operation) ⁹⁾
Max. switching frequency	⁵⁾ f_{S_max} / kHz	16
Power dissipation at rated operation	¹⁾ P_D / W	450
Overload current over time	³⁾ I_{OL} / %	„3.3.3.1 Overload characteristic (OL) for 400 V devices“
Maximum current 0Hz/50Hz at $f_s = 2$ kHz	I_{out_max} / %	191 / 216
Maximum current 0Hz/50Hz at $f_s = 4$ kHz	I_{out_max} / %	143 / 216
Maximum current 0Hz/50Hz at $f_s = 8$ kHz	I_{out_max} / %	71 / 202
Maximum current 0Hz/50Hz at $f_s = 16$ kHz	I_{out_max} / %	24 / 102
<i>continued on the next page</i>		

TECHNICAL DATA OF 400 V PEAK POWER DEVICES

Device size		17
Housing		3
Max. braking current	I_{B_max} / A	76
Min. braking resistor value	R_{B_min} / Ω	11
Braking transistor	⁶⁾	Max. cycle time: 120s; Max c.d.f.: 50%
Protective function for braking transistor		Short-circuit monitoring
Protection function braking transistor (Error GTR7 always on)	⁷⁾	Feedback signal evaluation and current switch-off (only for AC mains connection)
Max. motor cable length shielded	⁸⁾ // m	100

Table 16: Overview of the 400V Peak Power device data

- ¹⁾ Rated operation corresponds to $U_N = 400V$, rated switching frequency, output frequency = 50 Hz (4-pole standard asynchronous motor).
- ²⁾ The output frequency is to be limited in such a way that it does not exceed 1/10 of the switching frequency. Notice! Devices with a maximum output frequency higher than 599Hz are subject to export restrictions.
- ³⁾ The values refer in % to the rated output current I_N .
- ⁴⁾ Observe limitations „3.3.3.1 Overload characteristic (OL) for 400 V devices“.
- ⁵⁾ A detailed description of the derating „3.4.1.2 Switching frequency and temperature of the 400 V peak power devices“.
- ⁶⁾ The cyclic duration factor is additionally limited by the used braking resistor.
- ⁷⁾ The feedback signal evaluation monitors the functionality of the braking transistor. The current is switched off via the internal mains input bridge of the AC supply. There is no current switch-off with DC power supply.
- ⁸⁾ The maximum cable length depends on various factors. Further information can be found in the corresponding filter instructions.
- ⁹⁾ ED: 70%, T_p : 20s

3.3.2 Voltage and frequencies for 400V devices

Input voltages and frequencies		
Rated input voltage	U_N / V	400
Rated mains voltage (USA)	U_{N_UL} / V	480
Input voltage range	U_{IN} / V	280...550
Input phases		3
Mains frequency	f_N / Hz	50/60
Mains frequency tolerance	$\pm f_N / Hz$	2

Table 17: Input voltages and frequencies of the 400V devices

DC link voltage		
DC link rated voltage @ $U_N = 400V$	U_{N_dc} / V	565
DC link rated voltage @ $U_{N_UL} = 480V$	$U_{N_UL_dc} / V$	680
DC link voltage working voltage range	U_{IN_dc} / V	390...780

Table 18: DC link voltage for 400V devices

Output voltages and frequencies		
Output voltage at AC supply	1) U_{out} / V	0... U_{N_ac}
Output frequency	2) f_{out} / Hz	0...599
Output phase		3

Table 19: Output voltages and frequencies of the 400V devices

- 1) The voltage to the motor is dependent on the actual input voltage and the control method => („3.3.2.1 Example of the calculation of the possible motor voltage:“).
- 2) The output frequency is to be limited in such a way that it does not exceed 1/10 of the switching frequency. Devices with a maximum output frequency higher than 599Hz are restricted for export.

3.3.2.1 Example of the calculation of the possible motor voltage:

The motor voltage for dimensioning of the drive is depending on the used components. The motor voltage reduces according to the following table:

Component	Reduction / %	Example
Mains choke U_k	4	Open-loop drive controller with mains- and motor choke at non-rigid supply system: 400 V mains voltage (100%) - 36 V reduced voltage (11%) = 356 V motor voltage
Drive controller open-loop	4	
Drive controller closed-loop	8	
Motor choke U_k	1	
Non-rigid supply system	2	

Table 20: Example of the calculation of the possible motor voltage:

3.3.3 Input and output currents / overload for 400 V devices

Device size		17
Rated input current @ $U_N = 400V$	1) I_{in} / A	54
Rated input current @ $U_{N_UL} = 480/277V$	1) I_{in_UL} / A	41
Rated input current DC @ $U_{N_dc} = 565V$	I_{in_dc} / A	66
Rated input current DC @ $U_{N_UL_dc} = 680V$	$I_{in_UL_dc} / A$	50
Rated output current @ $U_N = 400 V$	I_N / A	42
Rated input current @ $U_{N_UL} = 480V / 277V$	I_{N_UL} / A	31,5
Rated output overload (60 s)	2) $I_{60s} / \%$	150
Overload current	2) $I_{OL} / \%$	=> „3.3.3.1 Overload characteristic (OL) for 400 V devices“
Software current limit	2) 3) $I_{lim} / \%$	180
Overcurrent	2) $I_{OC} / \%$	216

Table 21: Input and output currents of the 400 V peak power devices

- 1) The values resulting from rated operation with B6 rectifier circuit and mains choke 4% U_k .
- 2) The values refer in % to the rated output current I_N .
- 3) Limitation of the current setpoint in closed-loop operation. This setpoint limit is not active in v/f operation.

3.3.3.1 Overload characteristic (OL) for 400 V devices

All drive controllers can be operated at rated switching frequency with an utilisation of 150 % for 60s.

The OL overload function is a root mean square (RMS) function.

The greater the difference between the overload and underload phases, the greater the deviation of the RMS from the arithmetic mean value.

For extreme overloads (=> „*Figure 5: Switch-off time t depending on the overload I/I_N (OL)*“), the load is weighted more heavily. This means the load is provided with a factor for the calculation of the RMS value, by way that the overload protection function triggers, even if the RMS value does not reach 100%.

Restrictions:

The thermal design of the heat sink is based on the rated operation. The following values are taken into account: Rated output current, ambient temperature, rated switching frequency, rated voltage.

- At high ambient temperatures and/or high heat sink temperatures (for example, by preceding utilisation nearby 100%) the drive controller can change to overtemperature error before triggering the protective function OL.
- At low output frequencies or switching frequencies higher than the rated switching frequency, the frequency-dependent maximum current can be exceeded before and error OL2 can be triggered => „*3.3.3.1 Overload characteristic (OL) for 400 V devices*“.

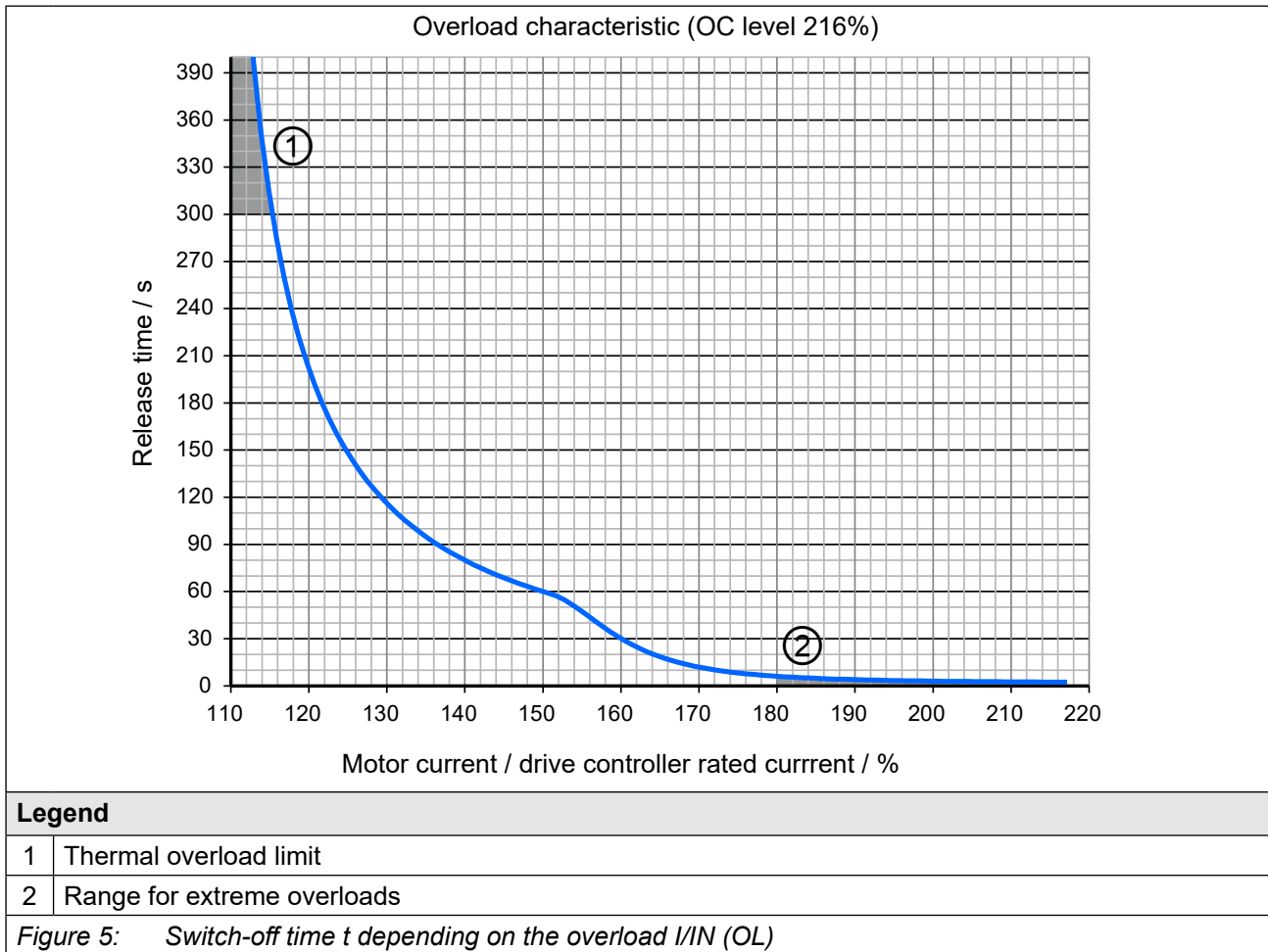

- On exceeding a load of 105 % the overload integrator starts.
- When falling below the integrator counts backwards.
- If the integrator reaches the overload characteristic "Error! overload (OL)" is triggered.

After a cooling down period, the integrator can be reset now. The drive controller must remain switched on during the cooling down phase.

Operation in the range of the thermal overload limit

Due to the high steepness of the overload characteristic, the duration of a permissible overload in this range ① cannot be determined exactly. Therefore, the design of the drive controller should be assumed to have a maximum overload time of 300s.

3.3.3.2 Frequency-dependent maximum current (OL2) for 400 V Peak Power devices

The characteristics of the maximum currents for a switching frequency which are depending on the output frequency are different for each drive controller, but the following rules are generally applicable:

- Applies for the rated switching frequency: At 0 Hz output frequency the drive controller can provide at least the rated output current.
- Lower maximum currents apply for switching frequencies > rated switching frequency.

If error (OL2) shall be triggered on exceeding the maximum currents or if the switching frequency is automatically reduced (derating) can be adjusted in the drive controller parameters.

The following characteristic curve indicates the permissible maximum current for the output frequency values 0 Hz, 3 Hz, 6 Hz, 12.5 Hz, 25 Hz and 50 Hz. Device size 17 is represented exemplary (with 4 kHz rated switching frequency).

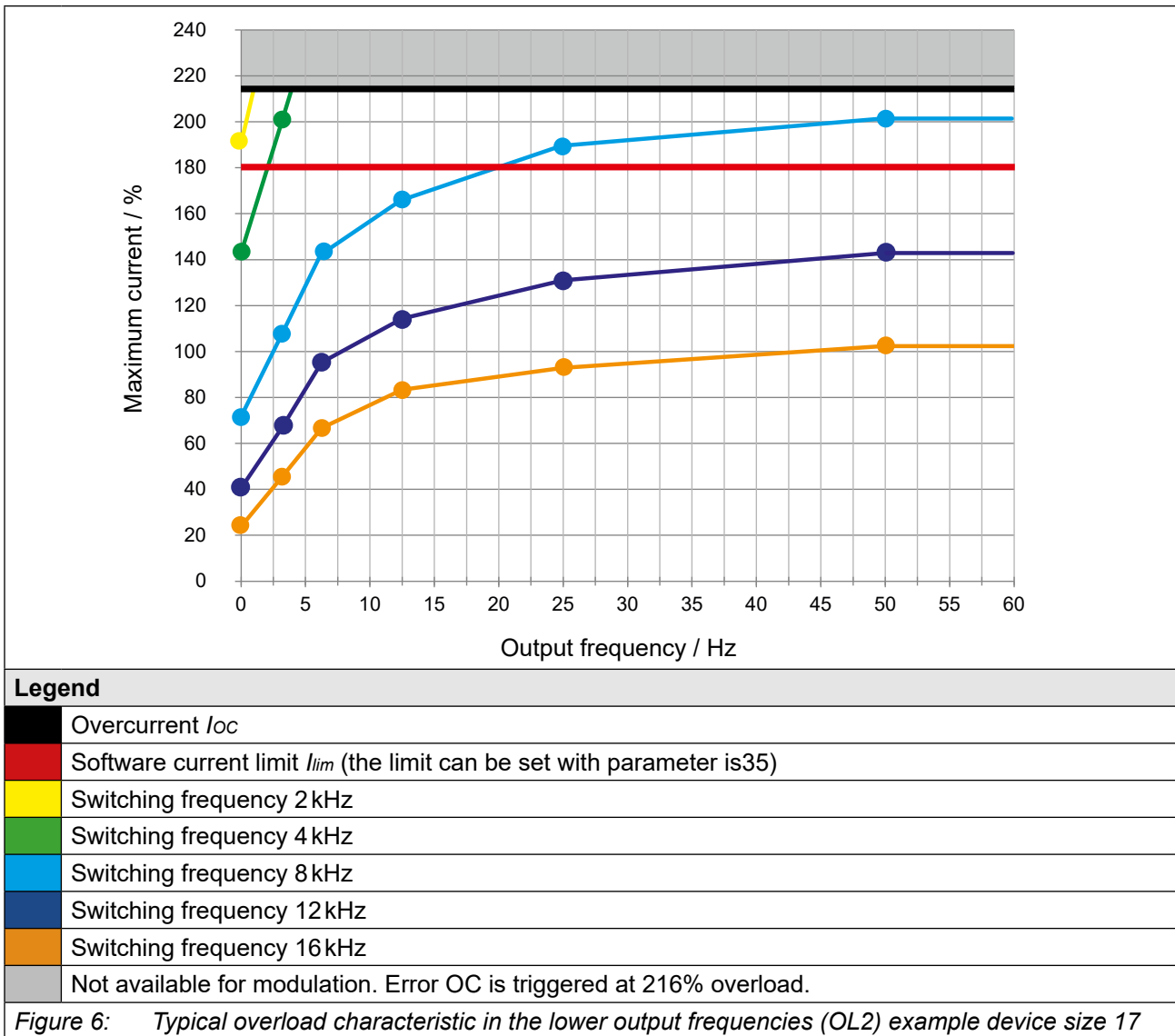

Figure 6: Typical overload characteristic in the lower output frequencies (OL2) example device size 17



The frequency-dependent maximum current I_{out_max} / % refers in % to the rated output current I_N .

The current remains constant from the last specified output frequency value.



The values for the respective device size are listed in the following tables.

Frequency-dependent maximum current

Device size	17						
Rated switching frequency	4kHz (S1 operation), 8kHz (S3 operation) ¹⁾						
Output frequency	f_{out} / Hz	0	3	6	12,5	25	50
Frequency-dependent maximum current @ f_s i_{out_max} / % Basic Time Period = 62.5 μ s (Parameter is22=0)	2 kHz	191	216	216	216	216	216
	4 kHz	143	200	216	216	216	216
	8 kHz	71	107	143	167	191	202
	16 kHz	24	45	67	83	93	102
Frequency-dependent maximum current @ f_s i_{out_max} / % Basic Time Period = 71.4 μ s (Parameter is22=1)	1.75 kHz	191	216	216	216	216	216
	3.5 kHz	155	216	216	216	216	216
	7 kHz	89	130	171	196	216	216
	14 kHz	32	56	81	99	112	123
Frequency-dependent maximum current @ f_s i_{out_max} / % Basic Time Period = 83.3 μ s (Parameter is22=2)	1.5 kHz	191	216	216	216	216	216
	3 kHz	167	216	216	216	216	216
	6 kHz	107	154	200	216	216	216
	12 kHz	41	67	95	114	131	143
Frequency-dependent maximum current @ f_s i_{out_max} / % Basic Time Period = 100 μ s (Parameter is22=3)	1.25 kHz	191	216	216	216	216	216
	2.5 kHz	179	216	216	216	216	216
	5 kHz	125	177	216	216	216	216
	10 kHz	56	87	119	141	161	173

Table 22: Frequency-dependent maximum current for device size 17

¹⁾ ED: 70%, T_p : 20s

3.3.4 Overview of rectifier data for 400 V appliances

Device size	17	
Rectifier rated power	P_{rect} / kW	21
Rectifier continuous power	¹⁾ P_{rect_cont} / kW	41
Continuous input current @ $U_N = 400$ V	¹⁾ i_{in_cont} / A	82
Continuous input current @ $U_{N_UL} = 480$ V	¹⁾ $i_{in_UL_cont}$ / A	71
Rated output current DC @ $U_{N_dc} = 565$ V	i_{out_dc} / A	66
Continuous output current DC @ $U_{N_dc} = 565$ V	¹⁾ $i_{out_dc_cont}$ / A	101
Rated output current DC @ $U_{N_UL_dc} = 680$ V	$i_{out_UL_dc}$ / A	50
Continuous output current DC @ $U_{N_UL_dc} = 680$ V	¹⁾ $i_{out_UL_dc_cont}$ / A	88

Table 23: Overview of rectifier data for 400 V appliances

¹⁾ Continuous operation is a load that exceeds the rated operation. Continuous operation only occurs if the internal rectifier is used to supply additional drive controllers via the DC terminals => „5.3.6 DC-Verbund“. In continuous operation, the OH error can be triggered depending on the operating conditions of the internal inverter.

3.3.5 Power dissipation at rated operation of the 400 V Peak Power devices

Device size	17	
Rated switching frequency	f_{SN} / kHz	4 (S1 operation), 8 (S3 operation) ¹⁾
Power dissipation at rated operation	²⁾ P_D / W	450
Power dissipation at rated operation DC	³⁾ P_{D_dc} / W	300

Table 24: Power dissipation of the 400 V Peak Power devices

¹⁾ ED: 70%, T_p : 20s

²⁾ Rated operation corresponds to $U_N = 400$ V; $f_{SN} = 4$ kHz; I_N ; $f_N = 50$ Hz (typically value)

³⁾ Rated operation DC corresponds to $U_{N_dc} = 565$ V; I_N (typical value)

3.3.6 Fusing of the 400V devices

3.3.6.1 Fuse protection for 400V AC supply

Device size	Max. size of the fuse / A			
	$U_N = 400$ V gG (IEC)	$U_N = 480$ V / 277V class „J“	$U_N = 480$ V / 277V	
	SCCR 30 kA	SCCR 5 kA	SCCR 30 kA	Type
17	63	45	50	SIBA 20 189 20.50
			50	COOPER BUSSMANN 170M1364
			50	LITTELFUSE L70QS050

Table 25: Fusings of the 400 V peak power devices



Short-circuit capacity

According to the requirements of EN 61439-1 and EN 61800-5-1, the following applies to connection to a power supply: The devices are suitable for use in a circuit capable of delivering not more than 30 kA eff. unaffected symmetrical short-circuit current.

3.3.6.2 Protection of 400 V devices with DC power supply

Device size	Recommended size of the fuse / A		Permissible fuses ¹⁾
	$U_{N_dc} = 565V$	$U_{N_dc} = 680V$	
	SCCR 50 kA	SCCR 50 kA	
17	90	80	SIBA 50 250 06.80 SIBA 20 209 37.100 ²⁾ SIBA 50 280 06.100 SIBA 50 268 06.125 SIBA 20 031 34.125 Bussmann FWP-100A22F Bussmann 170M1420 Littelfuse L70QS200

Table 26: DC-Fusing of the 400 V / 480 V devices

- ¹⁾ Fuses of the same type with lower rated currents can be used if they are suitable for the application.
- ²⁾ Fuse without UL certification

NOTICE

Observe the rated voltage of the fuse!

- ▶ The rated voltage of the fuse must be at least equal to the maximum DC supply voltage of the drive controller.

3.3.6.3 Motor protection switch / circuit breaker

This chapter lists the recommended and alternative motor protection switches/circuit breakers for protecting the drive controller. The selection of the recommended protection switches is based on continuous operation (S1 operation) at 100% load and maximum ambient temperature. If operating conditions differ, the circuit breakers must be dimensioned accordingly (see manufacturer’s documentation for the respective circuit breakers).

Device size	Motor protection switch / circuit breaker						
	IEC ($U_N = 400V$)			UL ($U_{N_UL} = 480V$)			
	Type	Rated current / A	SCCR @ U_N / kA	Type	Rated current / A	Rated power / hp	SCCR @ U_{N_UL} / kA
17	Eaton PKZM4-58	58	30	Eaton PKZM4-50	50	30	30

Table 27: Recommended motor protection switches/circuit breakers for 400 V/480 V devices

As an alternative to the recommended motor protection switches/circuit breakers, all circuit breakers listed in the following table may be used. Circuit breakers of the same type with a lower rated current or other features (e.g., connection terminals, actuation types, etc.) may also be used, provided that they are suitable for the application and the differing features do not have a negative effect on the pass values (I^2t and I_p). Circuit breakers of the same type with lower breaking capacity may be used provided they are suitable for the application. In this case, the short-circuit current rating (SCCR) of the combination of drive controller and circuit breaker is reduced to the breaking capacity of the circuit breaker.

Some motor circuit breakers require additional accessories in order to be used as Type E Combination Motor Controllers in UL-certified installations (see manufacturer’s documentation for the respective circuit breaker).

Recommended motor protection switches / circuit breakers			
Type	Rated current / A	Rated power / hp	SCCR @ U_N / kA
Eaton PKZM4-63	65	40	30
Siemens 3RV2032-4KA10	73	60	30
Siemens 3RV2042-4YA10	93	75	30
Schneider GV3P65	65	40	30
Siemens 3VA5110-6ED31-0AA0	100	-	30
Schneider B JL36100	100	-	30

Table 28: Recommended motor protection switches/circuit breakers for 400 V/480 V devices



IEC only:

- Motor protection switches/circuit breakers not listed here may be used provided they meet the following requirements:
- Passage integral I^2t @ $U_N < 470 \text{ kA}^2\text{s}$
 - Passing current I_p @ $U_N < 17\text{kA}$

3.4 General electrical data

3.4.1 Switching frequency and temperature

The drive controller cooling is designed by way that the heat sink overtemperature threshold is not exceeded at rated conditions. A switching frequency higher than the rated switching frequency also produces higher losses and thus a higher heat sink heating. If the heat sink temperature reaches a critical threshold (T_{DR}), the switching frequency can be reduced automatically step by step. This prevents that the drive controller switches off due to overheating of the heat sink. If the heat sink temperature falls below the threshold T_{UR} , the switching frequency is increased back to the setpoint. At temperature T_{EM} the switching frequency is immediately reduced to rated switching frequency. „Derating“ must be activated, for this function to work.

3.4.1.1 Switching frequency and temperature of the 230 V peak power devices

Device size		15
Rated switching frequency	¹⁾ f_{SN} / kHz	8
Max. switching frequency	¹⁾ f_{S_max} / kHz	16
Min. switching frequency	¹⁾ f_{S_min} / kHz	2
Max. heat sink temperature	T_{HS} / °C	85
Temperature for derating the switching frequency	T_{DR} / °C	75
Temperature for uprating the switching frequency	T_{UR} / °C	65
Temperature for switching to rated switching frequency	T_{EM} / °C	80

Table 29: Switching frequency and temperature of the 230 V peak power devices

¹⁾ The output frequency is to be limited in such a way that it does not exceed 1/10 of the switching frequency.

3.4.1.2 Switching frequency and temperature of the 400 V peak power devices

Device size		17
Rated switching frequency	¹⁾ f_{SN} / kHz	4 (S1 operation), 8 (S3 lift operation)
Max. switching frequency	¹⁾ f_{S_max} / kHz	16
Min. switching frequency	¹⁾ f_{S_min} / kHz	2
Max. heat sink temperature	T_{HS} / °C	85
Temperature for derating the switching frequency	T_{DR} / °C	75
Temperature for uprating the switching frequency	T_{UR} / °C	65
Temperature for switching to rated switching frequency	T_{EM} / °C	80

Table 30: Switching frequency and temperature of the 400 V peak power devices

¹⁾ The output frequency is to be limited in such a way that it does not exceed 1/10 of the switching frequency.

3.4.2 DC link / braking transistor function



Activation of the braking transistor function

To be able to use the braking transistor, the function must be activated with parameter "is30 braking transistor function".

For more information => [F6 Programming manual](#).

NOTICE

Falling below the minimum braking resistor value!

Destruction of the drive controller

- ▶ The minimum brake resistance value must not fall below!

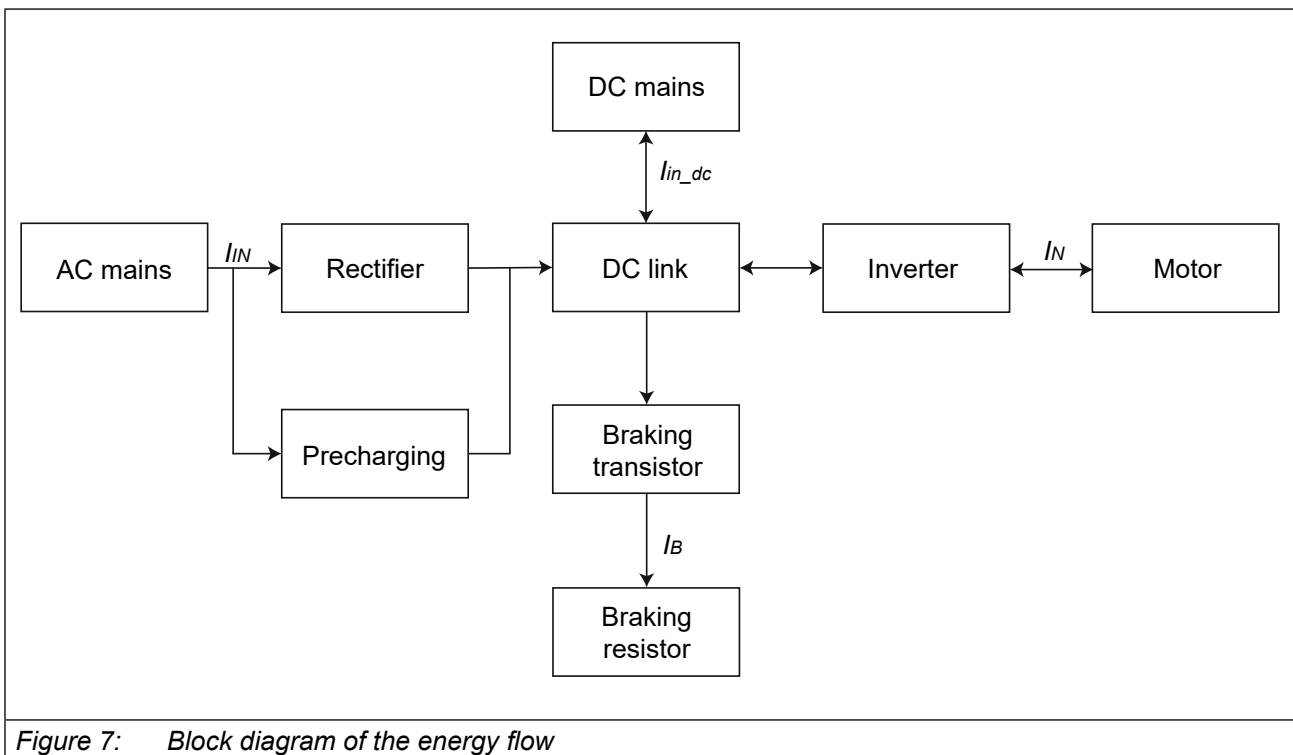

Figure 7: Block diagram of the energy flow

NOTICE

Destruction of the drive controller!

If the error "ERROR GTR7 always ON" occurs, the current consumption is switched off internally via the mains input bridge of the AC supply.

- ▶ If the error "ERROR GTR7 always ON" occurs, the drive controller is defective and must be disconnected from the power supply no later than 16 hours!
- ▶ With DC mains connection and the use of non-intrinsically safe braking resistors or sub-mounted braking resistors, the drive controller must be de-energised after 1 second at the latest.

3.4.2.1 DC link / braking transistor function of the 230 V peak power devices

Device size		15
DC link rated voltage @ $U_N = 230\text{ V}$	U_{N_dc} / V	325
DC link rated voltage @ $U_{N_UL} = 240\text{ V}$	$U_{N_dc_UL} / \text{V}$	339
DC link voltage working voltage range	U_{in_dc} / V	240...373
DC switch-off level "ERROR underpotential"	U_{UP} / V	216
DC switch-off level "ERROR overpotential"	U_{OP} / V	400
DC switch-off level braking resistor	¹⁾ U_B / V	380
Max. braking current	I_{B_max} / A	76
Min. braking resistor value	R_{B_min} / Ω	5,3
Braking transistor	²⁾	Max. cycle time: 120 s; Max c.d.f.: 50 %
Protective function for braking transistor		Short-circuit monitoring
Protection function braking transistor (Error GTR7 always on)	³⁾	Feedback signal evaluation and current shutdown
DC link capacity	$C_{int} / \mu\text{F}$	5040

Table 31: DC link / braking transistor function of the 230 V peak power devices

- ¹⁾ The DC switching level for the braking transistor is adjustable. The default value is the value specified in the table.
- ²⁾ The cyclic duration factor is additionally limited by the used braking resistor.
- ³⁾ The feedback signal evaluation monitors the functionality of the braking transistor. The current is switched off via the internal mains input bridge of the AC supply.
- ³⁾ The feedback signal evaluation monitors the functionality of the braking transistor. The current is switched off via the internal mains input bridge of the AC supply.

3.4.2.2 DC link / braking transistor function of the 400V peak power devices

Device size		17
DC link rated voltage @ $U_N = 400\text{ V}$	U_{N_dc} / V	565
DC link rated voltage @ $U_{N_UL} = 480\text{V} / 277\text{V}$	$U_{N_dc_UL} / \text{V}$	680
DC link voltage working voltage range	U_{in_dc} / V	390...780
DC switch-off level "ERROR underpotential"	U_{UP} / V	240
DC switch-off level "ERROR overpotential"	U_{OP} / V	840
DC switch-off level braking resistor	¹⁾ U_B / V	780
Max. braking current	I_{B_max} / A	76
Min. braking resistor value	R_{B_min} / Ω	11
Braking transistor	²⁾	Max. cycle time: 120 s; Max c.d.f.: 50 %
Protective function for braking transistor		Short-circuit monitoring
Protection function braking transistor (Error GTR7 always on)	³⁾	Feedback signal evaluation and current switch-off (only for AC mains connection)
DC link capacity	$C_{int} / \mu\text{F}$	1400
Max. prechargeable total capacity @ $U_N = 400\text{ V}$	⁴⁾ $C_{pc_max} / \mu\text{F}$	2300
Max. prechargeable total capacity @ $U_N = 480\text{ V}$	⁴⁾ $C_{pc_max_UL} / \mu\text{F}$	2300

Table 32: DC link / braking transistor function of the 400 V peak power devices

- ¹⁾ The DC switching level for the braking transistor is adjustable. The default value is the value specified in the table.
- ²⁾ The cyclic duration factor is additionally limited by the used braking resistor.
- ³⁾ The feedback signal evaluation monitors the functionality of the braking transistor. The current is switched off via the internal mains input bridge of the AC supply. There is no current switch-off with DC power supply.
- ⁴⁾ If the precharge time is shortened, only the internal DC link capacitance can be precharged => [F6 Programming manual](#).

3.4.3 Fan

Device size		15	17
Interior fan	Number	1	
	Speed-variable	no	
Heat sink fan	Number	1	
	Speed-variable	yes	

Table 33: Fan



The fans are speed variable. They are automatically controlled to high or low speed depending on the setting of the temperature limits in the software.

NOTICE

Destruction of the fan!

Take care that no foreign substances drop into the fan!

3.4.3.1 Switching behaviour of the fans

Temperature monitoring controls the fans with various switch-on and switch-off points.

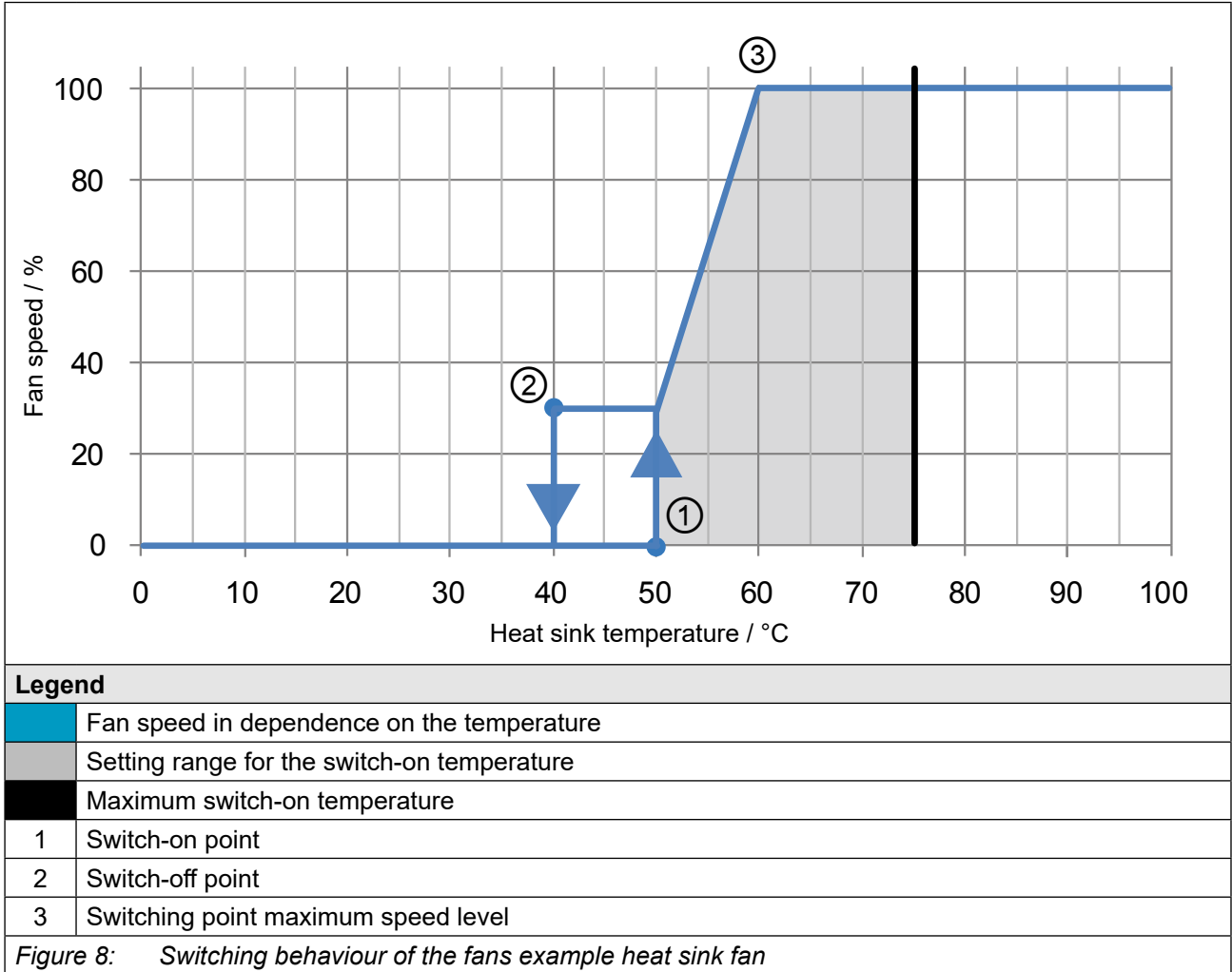

3.4.3.2 Switching points of the fans

The switching point for the switch-on temperature and the maximum speed level of the fans are adjustable. The following table shows the default values.

Fan		Heat sink	Interior
Switch-on temperature	$T / ^\circ\text{C}$	50	45
Maximum speed level	$T / ^\circ\text{C}$	60	55

Table 34: Switching points of the fans

4 Installation

4.1 Dimensions and weights

4.1.1 Built-in version air cooler

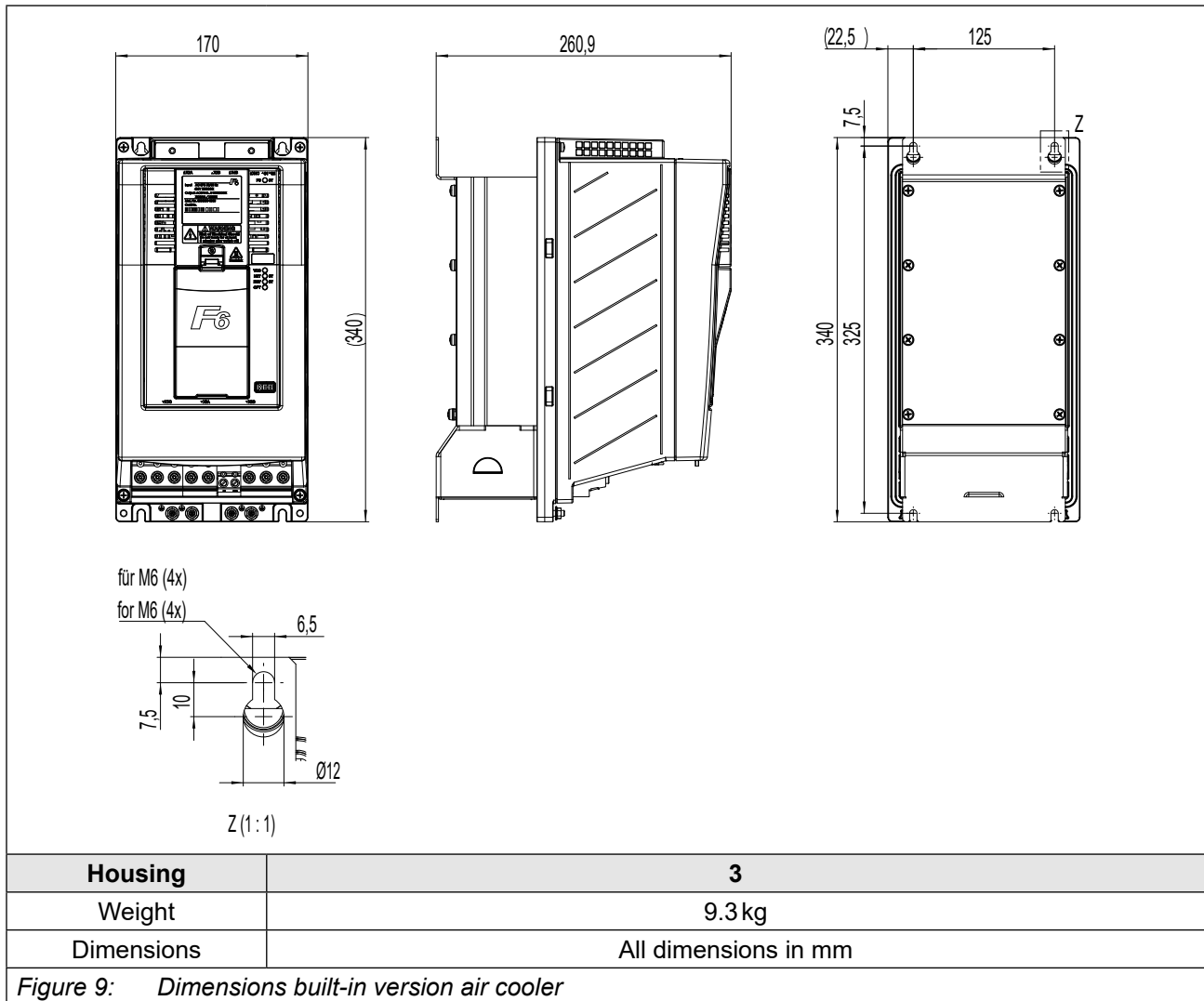

4.1.2 Push-through version air cooler IP20, IP54-ready

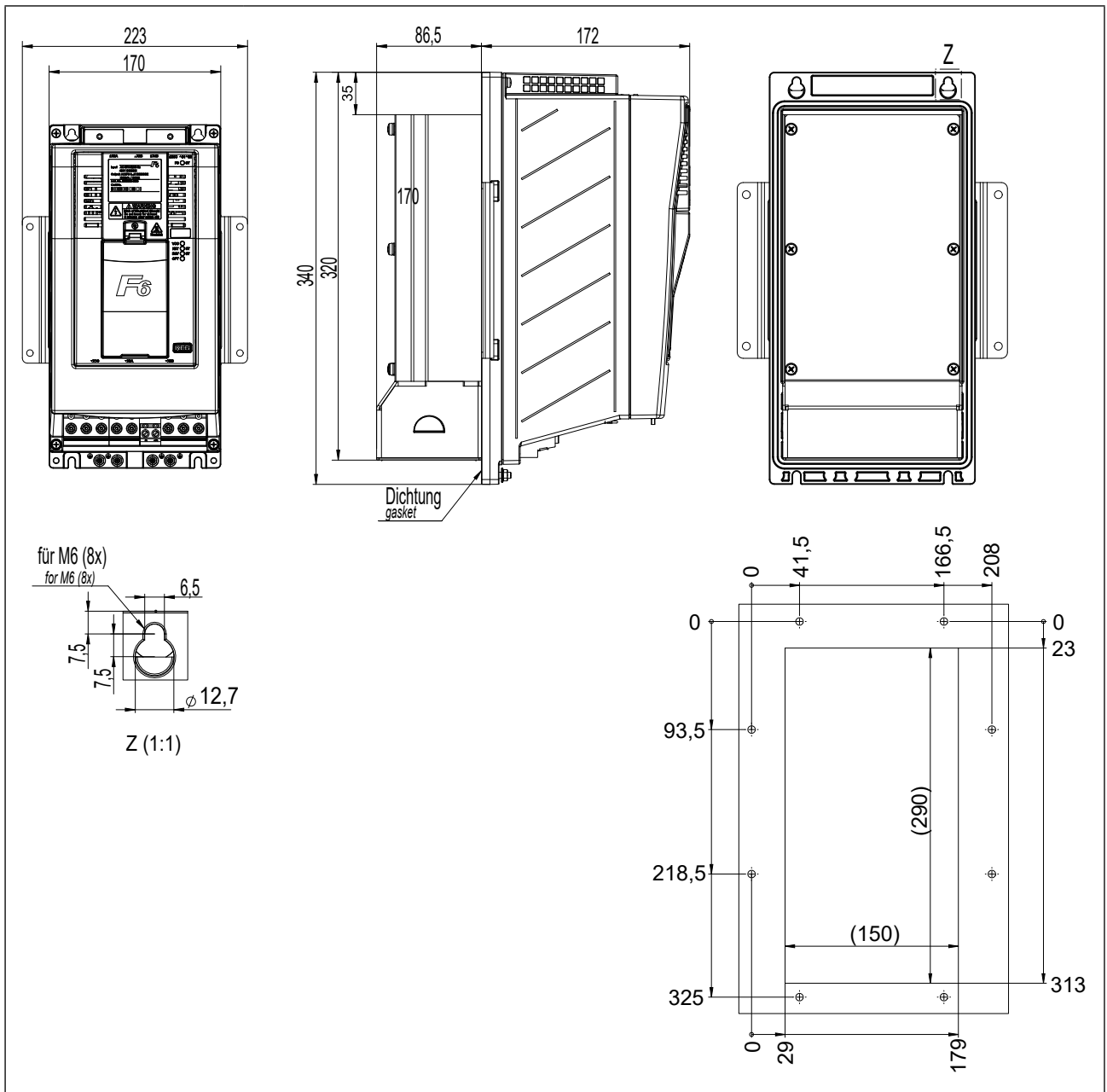

Housing	3
Weight	9.5 kg
Dimensions	All dimensions in mm

Figure 10: Dimensions push-through versions air cooler IP20, IP54-ready

4.2 Control cabinet installation

4.2.1 Mounting instructions

For the mounting of the drive controllers the following mounting materials with the appropriate quality were tested by KEB.

Required material	Tightening torque
Hexagon head screw <i>ISO 4017</i> - M6 - 8.8	9Nm 80lb inch
Flat washer <i>ISO 7090</i> - 6 - 200 HV	–
<i>Table 35: Mounting instructions for built-in version</i>	

Required material	Tightening torque
Hexagon head screw <i>ISO 4017</i> - M6 - 8.8	9Nm 80lb inch
Flat washer <i>ISO 7090</i> - 6 - 200 HV	–
<i>Table 36: Fastening instructions for push-through version</i>	

NOTICE

Use of other fixing material

- The alternatively selected fixing material must meet the above material characteristics (quality) and tightening torques!

The use of other fixing materials is beyond the control of KEB and is therefore the sole responsibility of the customer.

4.2.2 Mounting distances

Power dissipation for control cabinet design „3.3.5 Power dissipation at rated operation of the 400 V Peak Power devices“. A lower value can be used here depending on the operating mode/load.



Mounting the drive controller

For reliable operation, the drive controller must be mounted without any distance on a smooth, closed, metallicly bright mounting plate.

Mounting distances	Dimension	Distance in mm	Distance in inch
	A	150	6
	B	100	4
	C	30	1,2
	D	0	0
	E	0	0
	F ¹⁾	50	2
	¹⁾ Distance to preceding elements in the control cabinet door.		

Figure 11: Mounting distances

4.2.3 Installation of IP54-ready devices

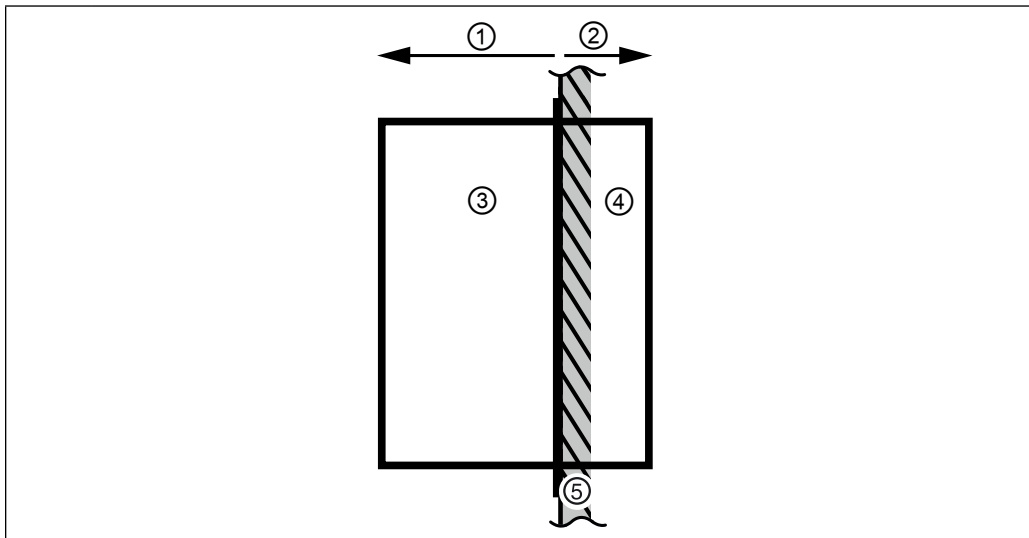

Legend	
1	IP20 zone inside the housing
2	IP54 zone outside the housing
3	Drive controller (power unit and control unit)
4	Drive controller (heat sink)
5	Housing (e.g. Control cabinet wall)

Figure 12: Installation of IP54-ready devices



IP54 zone: Heat sink outside the housing (Control cabinet)

The protection class IP54 can only be achieved when the device is properly installed.

For proper installation, a suitable IP54 seal (=> „5.4.2 Seal for IP54-ready devices“) must be installed between heat sink and housing (e.g. control cabinet wall).

The tightness must be checked after the installation. If properly installed, the separation to the housing corresponds to degree of protection IP54.

In the case of fan-cooled units, the fans must be protected from negative environmental influences.

These include combustible, oily or dangerous fumes or gases, corrosive chemicals, coarse foreign bodies and excessive dust. This applies especially to the access of the heatsink from the top (air outlet).Icing is inadmissible.

UL: Device heat sink is classified as NEMA type 1

IP20 zone: Device inside the housing

This part is intended for the installation in a suitable housing for the required degree of protection (e.g. control cabinet).

The power connections are excluded => „3.1.1 Climatic environmental conditions“.

NOTICE

Defect due to continuous splash water !

- ▶ Never expose the device to continuous splashing water (e.g. direct exposure to rain)!

4.2.4 Control cabinet ventilation

If construction-conditioned the control cabinet cannot be without indoor ventilation, appropriate filters must avoid suction of foreign objects.

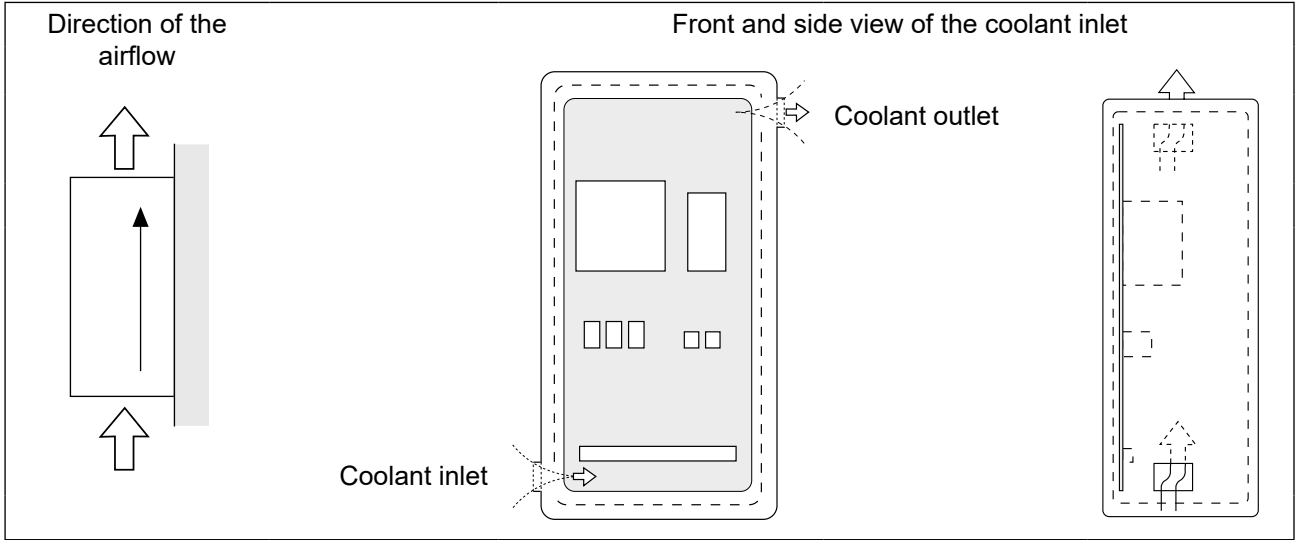
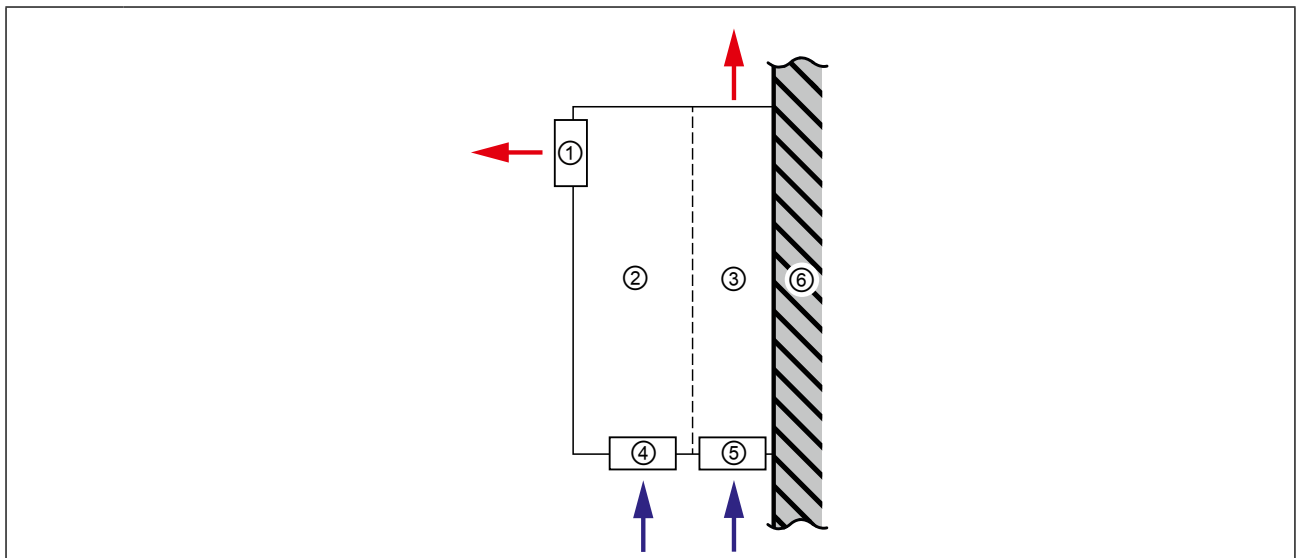

Figure 13: Control cabinet ventilation

4.2.5 Airflow of the drive controller



Legend	
	Airflow direction
1	Interior fan (from housing 4)
2	Drive controller (power unit and control)
3	Drive controller (heat sink)
4	Interior fan for (housing 2 and 3)
5	Heatsink fan
6	Housing (e.g. Control cabinet rear)

Figure 14: Airflow of the drive controller

5 Installation and connection

5.1 Overview of the COMBIVERT F6

Housing 3		No.	Name	Description
		1	---	Fixing points for the optional shield connection brackets. The shielding e.g. from the motor cable is laid on the mounting plate in the control cabinet or on the shield connection bracket (optionally available). Control unit: • 00F6V80-2000 Power unit: • 00F6V80-3001
		2	---	LEDs (=> manual for control unit chapter "Overview") • For control board COMPACT: FS without function. • For control card APPLICATION and PRO: Status indication of the safety module
		3	---	Nameplates
		4	PE	Protective earth; at connection to protective earth each terminal may be assigned only once
		5	X1A	Power circuit terminals for: • Mains input • Braking resistor • DC voltage interface • Motor connection
<p>Figure 15: F6 housing 3 top view</p>				

Housing 3		No.	Name	Description
	1	---	Fixing points for the optional shield connection brackets. The shielding e.g. from the motor cable is laid on the mounting plate in the control cabinet or on the shield connection bracket (optionally available). Power unit: • 00F6V80-3001	
	4	PE	Protective earth; at connection to protective earth each terminal may be assigned only once	
	5	X1A	Power circuit terminals for: • Mains input • Braking resistor • DC voltage interface • Motor connection	
	6	X1C	Terminal for: • Motor temperature monitoring • Brake control	
	7	X3A	Encoder interface channel A	
	8	X3B	Encoder interface channel B	
	9	---	Interior fan	
	10	---	Heat sink fan	
	1			
	1			

Figure 16: F6 housing 3 front view

Housing 3		No.	Name	Description
	11	S1	Rotary coding switch A	
	12	S2	Rotary coding switch B	
	13	X4C	Fieldbus interface (out)	
	14	X4B	Fieldbus interface (in)	
	15	X2B	Safety module	
	16	X2A	Control terminal block for <ul style="list-style-type: none"> • CAN bus • Analog inputs and analog output • Digital inputs and outputs • 24 V DC voltage supply 	

Figure 17: F6 housing 3 rear view with control board APPLICATION



Further information can be found in the respective control board manual.



Instructions for use COMBIVERT F6 control board APPLICATION
www.keb.de/fileadmin/media/Manuals/dr/ma_dr_f6-cu-a-inst-20118593_en.pdf



Instructions for use COMBIVERT F6 control board COMPACT
www.keb.de/fileadmin/media/Manuals/dr/ma_dr_f6-cu-k-inst-20144795_en.pdf



Instructions for use COMBIVERT F6 control board PRO
www.keb.de/fileadmin/media/Manuals/dr/ma_dr_f6-cu-p-inst-20182705_en.pdf



5.2 Connection of the power unit

NOTICE

Destruction of the drive controller!

- ▶ Never exchange mains input and motor output!

5.2.1 Connection of the voltage supply

The COMBIVERT F6 housing 3 can be supplied via terminals L1, L2 and L3 (AC power supply) or via terminals + and - (DC power supply with inrush current limitation)

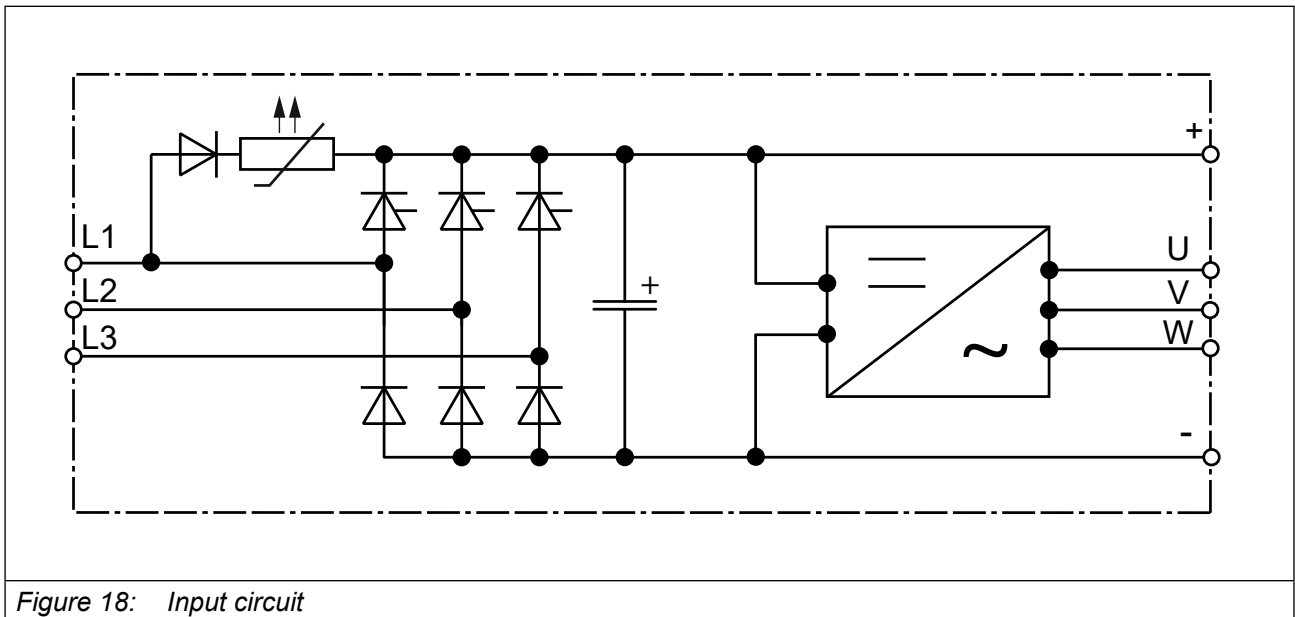

Figure 18: Input circuit

NOTICE

With AC power supply, observe the minimum waiting time between two switch-on processes!

Cyclical switching off and on of the drive converter leads to temporary high impedance of the PTC precharging resistor. Once the PTC pre-charging resistor has cooled down, it can be restarted without restriction. The waiting time between two switch-on processes depends on the external capacitance, the AC mains voltage and the ambient temperature.

- ▶ Without external capacity: 5 min
- ▶ With external capacity (additional drive converters): 5 min

NOTICE

No inrush current limitation with DC power supply!

- ▶ An external inrush current limiter must be provided for DC power supplies.

5.2.1.1 Terminal block X1A

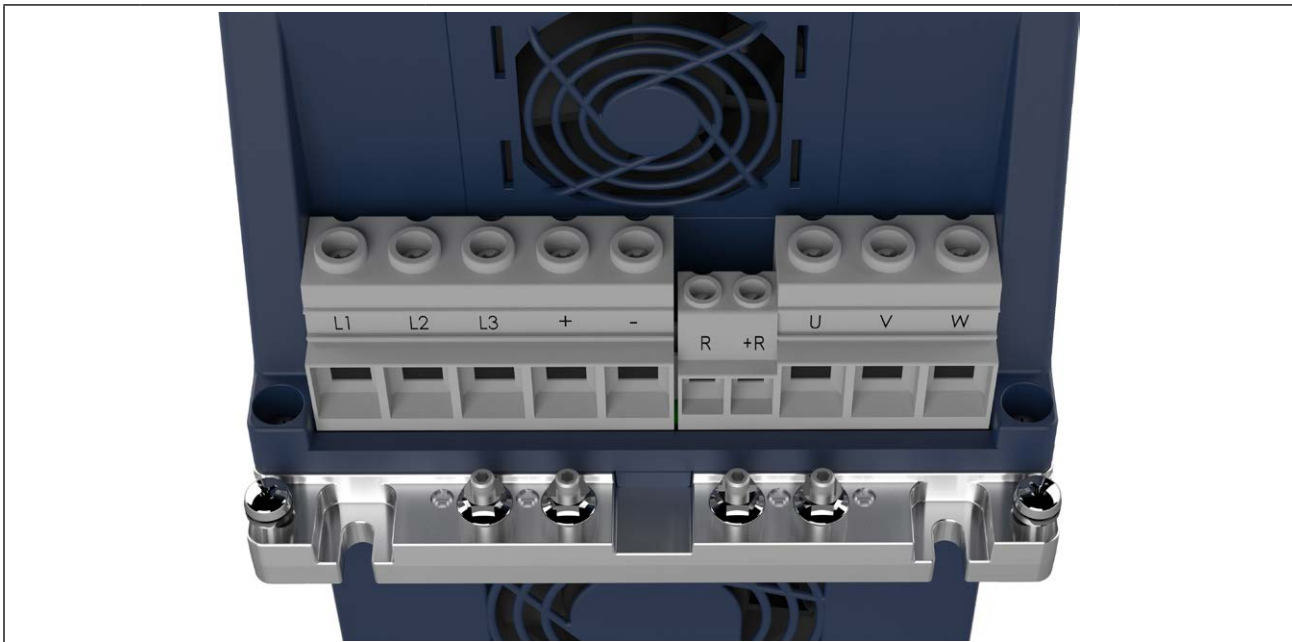

Name	Function	Cross section for terminal connection	Tightening torque	Max. number of conductors
L1	Mains connection 3-phase	Flexible cable with wire end ferrule 0.5...35 mm ² For 2 conductors max. 6mm ²	2.5...4.5 Nm 23...40lb inch	For IEC: 2 For UL: 1
L2				
L3				
+	DC terminals	UL: Flexible cable without wire end ferrule AWG 20...2		
-				
R	Connection for braking resistor (between R and +R)	Flexible cable with wire end ferrule 0.5...16 mm ² For 2 conductors max. 6mm ² UL: Flexible cable without wire end ferrule AWG 20...6	1.2...1.5 Nm 11...13lb inch	
+R				
U	Motor connection	See terminals L1, L2, L3	See terminals L1, L2, L3	
V				
W				

Figure 19: Terminal block X1A

5.2.2 Protective earth and functional earth



Protective and functional earth must not be connected to the same terminal.

5.2.2.1 Protective earth

The protective earth (PE) serves for electrical safety particularly personal protection in error case.



Electric shock due to incorrect dimensioning!



► Cross section wire to ground should be selected according to *VDE 0100!*

Name	Function	Terminal connection	Tightening torque
PE,	Connection for protective earth	5 mm threaded pin for M5 crimp connector	6...8 Nm 53...70 lb inch

Figure 20: Connection for protective earth



Incorrect installation of the PE connection

Only the M5 threaded pins with nut may be used to connect the protective earth!

5.2.2.2 Functional earthing

A functional earthing may also be necessary, if for EMC requirements additional potential equalization between devices or parts of the system must be available.



The use of the functional earth (FE) is not required if the frequency inverter is EMC-technically wired.

The functional earth may not be wired green/yellow!



Notes on EMC-compatible installation can be found here.
www.keb.de/fileadmin/media/Manuals/emv/0000neb0000.pdf



5.3 Mains connection

5.3.1 Supply cable

The conductor cross-section of the supply cable is determined by the following factors:

- Input current of the drive controller
- Used line type
- Installation and ambient temperatures
- The locally valid electrical regulations



The application engineer is responsible for the design!

5.3.2 AC mains connection

5.3.2.1 AC supply 3-phase

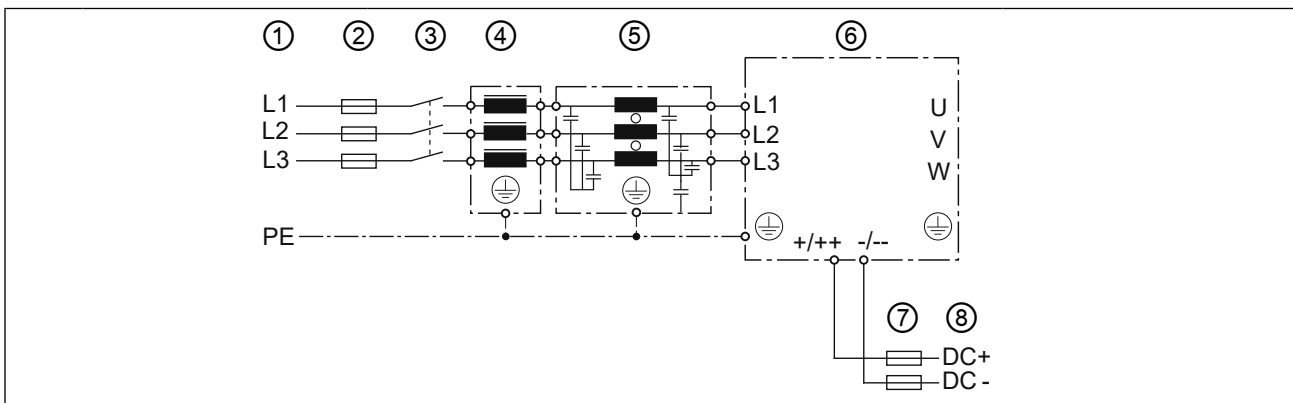

No.	Type	Description
1	Mains phase	3-phase
	Mains form	TN, TT
		IT
The rated voltage between one phase conductor and earth potential (or the neutral point in the IT system) must not exceed 300V. (For the IT system, a short-term disconnection must be ensured).		
	Personal protection	RCMA with separator or RCD type B Insulation monitors
2	Mains fuses	see chapter "Protection of the drive controllers"
3	Mains contactor	-
4	Mains choke	see notes in chapter "Filters and chokes"
5	HF filter for TN-, TT systems	Required for compliance with the limit values in accordance with EN 61800-3 .
	HF filter for IT systems	
6	Drive controller	COMBIVERT F6
7	DC-fuses	See note in chapter „Fusing of the devices“.
8	DC-supply	DC supply generated by the drive controller for connecting further drive controllers => „5.3.6 DC-bus connection“

Figure 21: Connection of the mains supply 3-phase

5.3.2.2 Note on hard power systems

The service life of drive controllers with voltage DC link depends on the DC voltage, ambient temperature and the current load of the electrolytic capacitors in the DC link. The use of mains chokes can increase the service life of the condensators to a considerable extent, especially when connecting to "hard" power systems or when under permanent drive load (continuous duty).

The term "hard" power system means that the nodal point power (S_{Net}) of the mains is very high ($\gg 200$) compared to the rated apparent output power of the drive controller (S_{out}).

$k = \frac{S_{Net}}{S_{out}} \gg 200$	e.g.	$k = \frac{2 \text{ MVA (supply transformer)}}{42 \text{ kVA (19F6)}} = 48 \longrightarrow$	no choke required
---------------------------------------	------	---	-------------------



A listing of filters and chokes => „5.4.1 Filters and chokes“.

5.3.3 DC mains connection

NOTICE

DC operation

- ▶ The DC power supply of 230V devices is only permitted after consultation with KEB!

5.3.3.1 Terminal block X1A DC connection

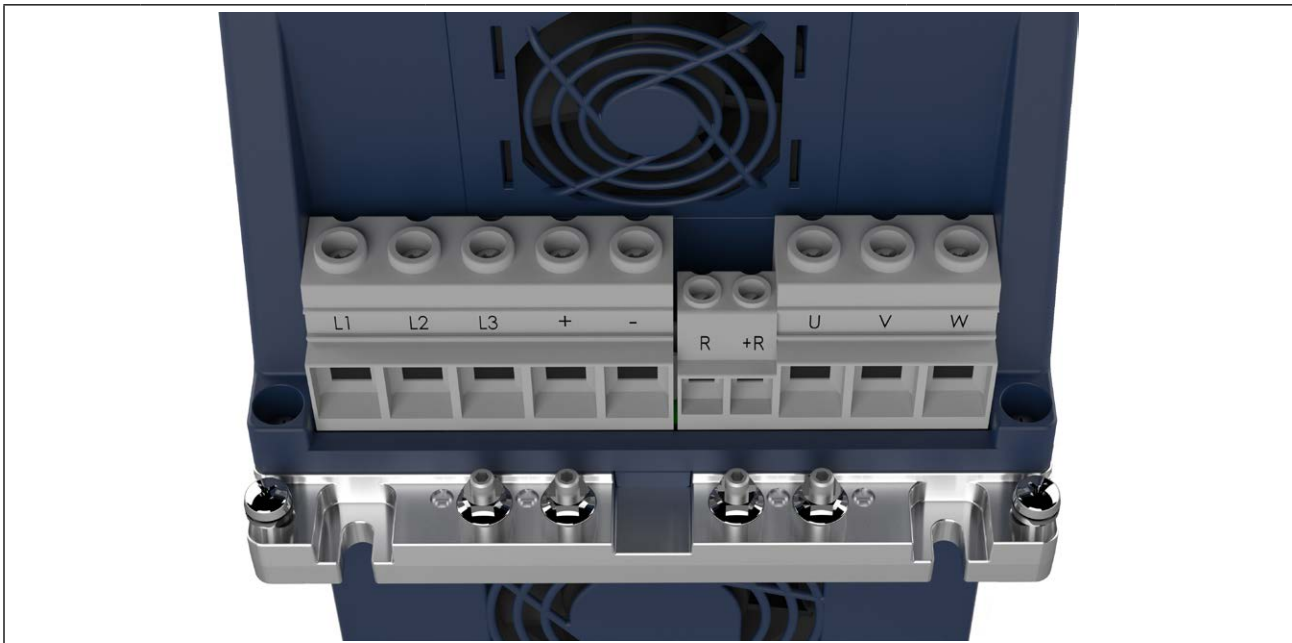

Name	Function	Cross section for terminal connection	Tightening torque	Max. number of conductors
+	DC terminals	Flexible cable with wire end ferrule 0.5...35 mm ² For 2 conductors max. 6mm ²	2.5...4.5 Nm	For IEC: 2
-		UL: Flexible cable without wire end ferrule AWG 20...2	23...40 lb inch	For UL: 1

Figure 22: Terminal block X1A DC connection

5.3.3.2 Connection at DC voltage supply

NOTICE

Destruction of the drive controller!

▶ Never exchange “+ / ++” and “- / --”!

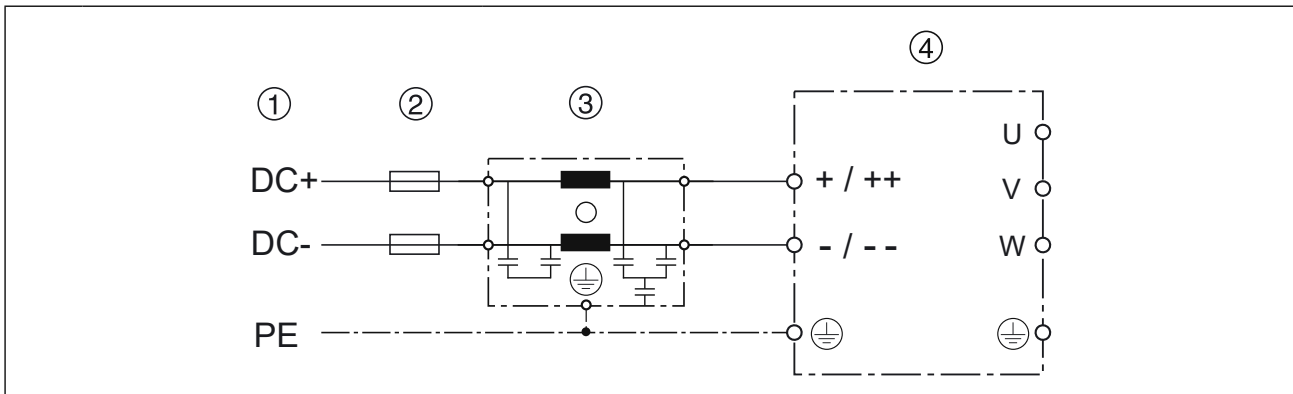

No.	Type	Description
1	Mains connection	2-phase
2	DC mains fuses	See note in chapter “Fuse protection for DC-supply”
3	HF-Filter	Type aR
4	Drive controller	COMBIVERT F6

Figure 23: Connection at DC voltage supply

5.3.4 Connection of the motor

5.3.4.1 Wiring of the motor

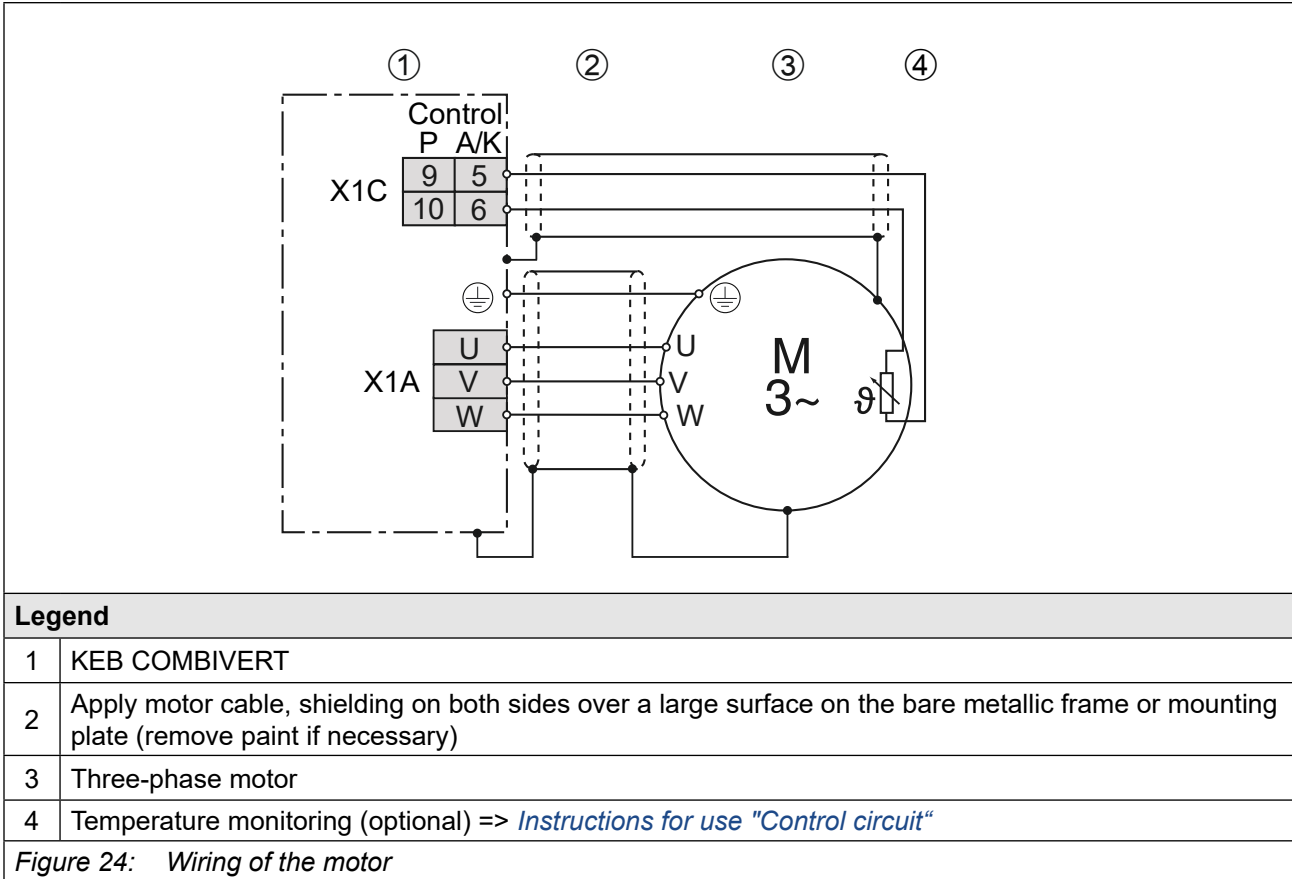
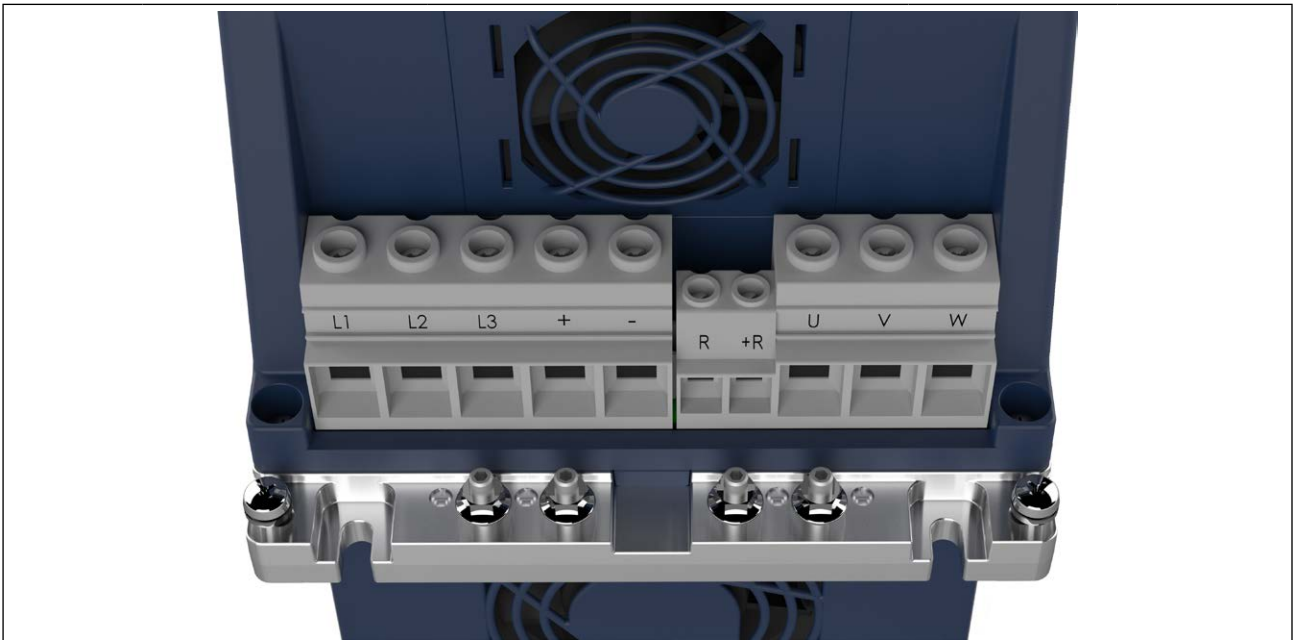

Figure 24: Wiring of the motor

5.3.4.2 Terminal block X1A motor connection



Name	Function	Cross section for terminal connection	Tightening torque	Max. number of conductors
U	Motor connection	Flexible cable with wire end ferrule 0.5...35 mm ² For 2 conductors max. 6mm ² UL: Flexible cable without wire end ferrule AWG 20...2	2.5...4.5Nm 23...40lb inch	For IEC: 2 For UL: 1
V				
W				

Figure 25: Terminal block X1A motor connection

5.3.4.3 Selection of the motor line

The correct cabling as well as the motor line itself play an important part in case of low power in connection with long motor line lengths. Low-capacitance line (phase/phase < 65 pF/m, phase/screen < 120 pF/m) at the inverter output have the following effects:

- allow major motor line lengths („5.3.4.4 Motor cable length and conducted interferences at AC supply“)
- better EMC properties (reduction of the common-mode output currents to earth)

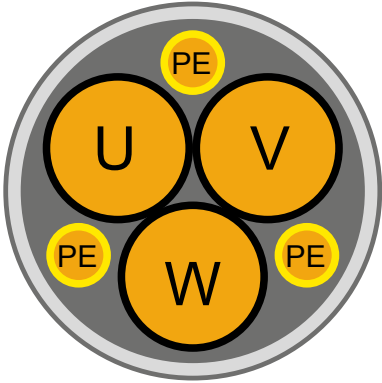
	<p>The use of shielded motor lines with symmetrical structure is required for higher motor power (from 30 kW). In these lines the protective earth conductor is tripartite and evenly arranged between the phase lines. A cable without protective earth conductor can be used if local regulations so permit. Then the protective earth conductor must be laid externally. Certain lines also permit the shield for the use as protective earth conductor. For this, observe the details of the line manufacturer!</p>
<p>Figure 26: Symmetrical motor line</p>	

5.3.4.4 Motor cable length and conducted interferences at AC supply

The maximum motor cable length is depending on the capacity of the motor cable as well as on the EMC emitted interference. External measures must be taken here (e.g. the use of a line filter).



The cable length can be significantly increased by using motor chokes or motor filters. KEB recommends the use of motor chokes or filters for a cable length upto 25 m.



Further information on the motor cable length can be found in the corresponding filter instructions.

5.3.4.5 Motor cable length for parallel operation of motors

The resulting motor cable length for parallel operation of motors, or parallel installation with multiple cables arises from the following formula:

$$\text{Resulting motor cable length} = \sum \text{single cable length} \times \sqrt{\text{Number of motor cables}}$$

5.3.4.6 Motor cable cross-section

The motor cable cross-section is dependent

- on the characteristic of the output current (e.g. harmonic content)
- on the real effective value of the motor current
- on the cable length
- on the type of the used cable
- on the ambient conditions such as bundling and temperature

5.3.4.7 Interconnection of the motor

NOTICE

Incorrect behavior of the motor!

- ▶ The connecting-up instructions of the motor manufacturer are always generally valid!

NOTICE

Protect motor against voltage peaks!

- ▶ Drive controllers switch at the output with high dv/dt . Voltage peaks that endanger the insulation system at the motor can occur especially in case of long motor cables (>15 m). A motor choke, a dv/dt -filter or sine-wave filter can be used to protect the motor with regard to the operating mode.

5.3.4.8 Connection of the temperature monitoring and brake control (X1C)

A switchable temperature evaluation is implemented in the COMBIVERT.

There are different types for the evaluation available. These are depending on the control board => *Instruction manual „control board“*.

The desired operating mode can be adjusted via software (dr33). If the evaluation is not required, it must be deactivated via software (parameter pn12 = 7) => *Programming manual*.

X1C	PIN	Name	Description
	1	BR+	Brake control / output +
	2	BR-	Brake control / output -
	3	reserved	–
	4	reserved	–
	5	TA1	Temperature detection / output +
	6	TA2	Temperature detection / output -

Figure 27: Terminal block X1C for control board APPLICATION and COMPACT

X1C	PIN	Name	Description
	1	BR+	Brake control / output +
	2	BR-	Brake control / output -
	3	0V	For supply of the checkback inputs
	4	24Vout	
	5	DIBR1	Checkback input 1 for brake and relay
	6	DIBR2	Checkback input 2 for brake and relay
	7	reserved	–
	8	reserved	–
	9	TA1	Temperature detection / output +
	10	TA2	Temperature detection / output -

Figure 28: Terminal block X1C for control board PRO

NOTICE

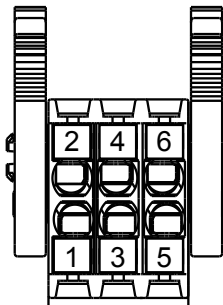
Malfunctions due to incorrect line or laying!

Malfunctions of the control due to capacitive or inductive coupling.

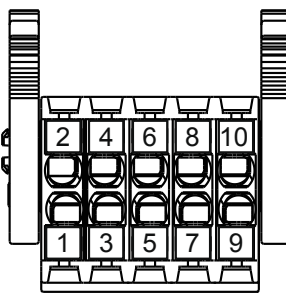
- ▶ Do not route cables from the motor temperature sensor (also shielded) together with control cables.
- ▶ Cables from the motor temperature sensor within the motor cables may only be used with double shielding!
- ▶ The input of the temperature detection has basic isolation.

		<p>For control board APPLICATION and COMPACT. The voltage to the control of a brake is decoupled from the internal voltage supply. The brake works only with external voltage supply.</p> <p>For control board PRO The brake can be supplied with both, internal and external voltage. Voltage tolerances and output currents vary for internal and external voltage supply..</p>
1	COMBIVERT	<p>Respect the specifications => Instruction manual „control board“</p>
4	Brake	
<p>Figure 29: Connection of the brake control</p>		

		<p>KTY sensors are polarized semiconductors and must be operated in forward direction! To this connect the anode to TA1 and the cathode to TA2! Non-observance leads to incorrect measurements in the upper temperature range. A protection of the motor winding is then no longer guaranteed.</p>
1	Connection via shield plate (if not available, place on the mounting plate).	
<p>Figure 30: Connection of a KTY sensor</p>		

NOTICE

- No protection of the motor winding in case of wrong connection.**
- ▶ Operate KTY sensors in forward direction.
 - ▶ KTY sensors may not be combined with other detections.



Further information about the wiring of the temperature monitoring and the brake control have to be observed in the respective control unit manual.

5.3.5 Connection and use of a braking resistor

⚠ CAUTION



Fire risk by using brake resistors!

- ▶ The risk of fire can be significantly reduced by using „intrinsically safe braking resistors“ or by using suitable monitoring functions / circuits.

NOTICE

Destruction of the frequency inverter if the value has fallen below the minimum brake resistance value!

- ▶ The minimum brake resistance value must not fall below!
„3.3 Technical data of 400 V peak power devices“

⚠ CAUTION



Hot surfaces caused by load of the braking resistor!

Burning of the skin!

- ▶ Cover hot surfaces safe-to-touch.
- ▶ Before touching, check the surface.
- ▶ If necessary, attach warning signs on the system.

5.3.5.1 Terminal block X1A connection braking resistor

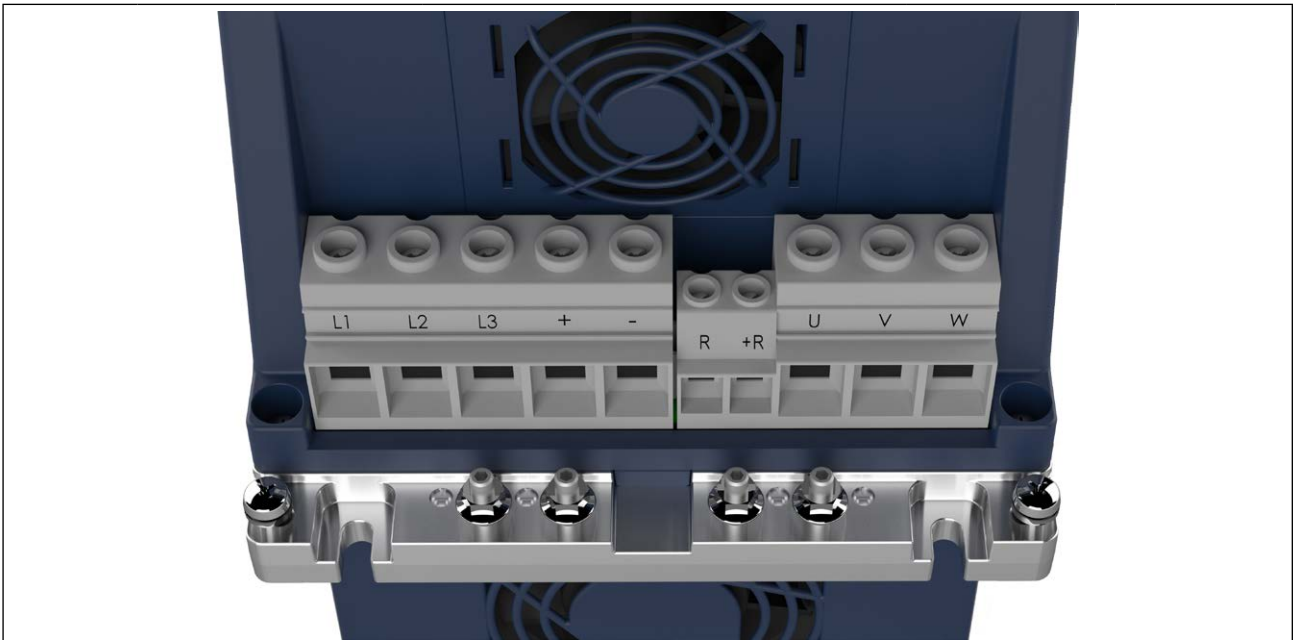

Name	Function	Cross section for terminal connection	Tightening torque	Max. number of conductors
R	Connection for braking resistor (between R and +R)	Flexible cable with wire end ferrule 0.5...16 mm ² For 2 conductors max. 6mm ²	1.2...1.5 Nm	For IEC: 2
+R		UL: Flexible cable without wire end ferrule AWG 20...6	11...13 lb inch	For UL: 1

Figure 31: Terminal block X1A connection braking resistor

5.3.5.2 Use of intrinsically safe braking resistors

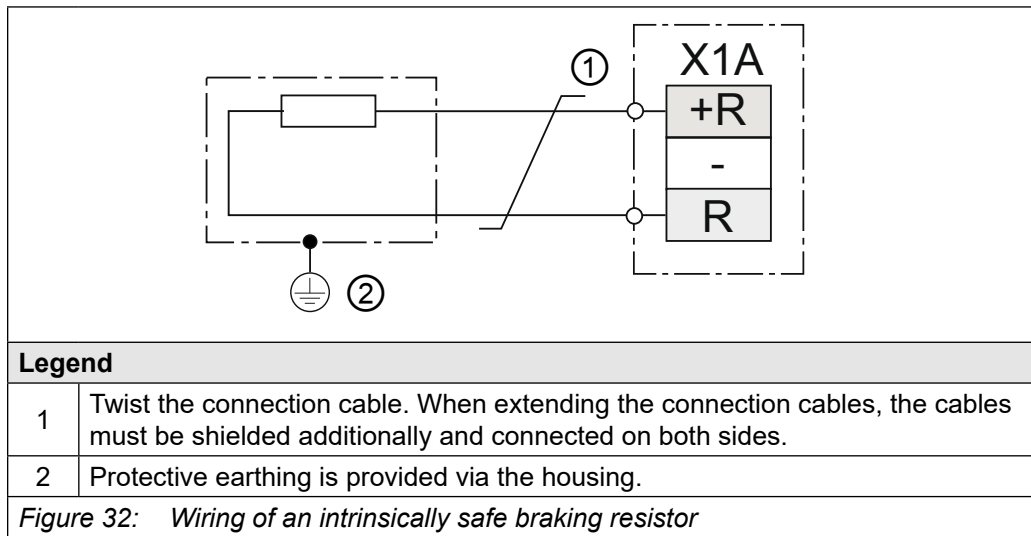

Intrinsically safe braking resistors behave in error case such as a safety fuse. They interrupt themselves without fire risk.

More information about intrinsically safe braking resistors
https://www.keb.de/fileadmin/media/Manuals/dr/ma_dr_safe-braking-resistors-20106652_en.pdf



5.3.5.3 Use of non-intrinsically safe braking resistors

WARNING



Use of non-intrinsically safe braking resistors

Fire or smoke emission in case of overload or error!

- ▶ Only use braking resistors with temperature sensor.
- ▶ Evaluate temperature sensor.
- ▶ Trigger an error at the drive controller (e.g. external input).
- ▶ Switch off input voltage (e.g. input contactor).
- ▶ Connection examples for non-intrinsically safe braking resistors
- ▶ => *Instructions for use "Installation braking resistors"*



Instructions for use "Installation braking resistors"
 => *Instructions for use "Installation braking resistors"*



5.3.6 DC-bus connection

The DC link of several drive controllers are coupled in a DC-bus connection. This enables energy to be exchanged between the devices and increases the energy efficiency of the application.

As part of a DC-bus connection, this drive controller can either be supplied via the DC terminals => „5.3.3 DC mains connection“ or supply other drive controllers via the DC terminals => „5.3.2 AC mains connection“.



KEB drive controllers meet the requirements of the EMC product standard [EN IEC 61800-3](#) for DC power supplies. Due to the large number of possible interconnection options in the DC network, the user is responsible for ensuring the conformity of the overall system.

The following additional safety instructions must be observed when using this drive controller in a DC-bus connection:

- This drive controller may only be operated together with other F6 and S6 drive controllers of the 400V class in a DC-bus connection.
- This drive controller must be installed in an enclosure.
- This drive controller must be protected with fuses at the DC terminals => „3.3.6.2 Protection of 400 V devices with DC power supply“.
- If one fuse in the DC-bus connection blows as a result of a short circuit, all fuses in the DC-bus connection should be replaced due to the risk of prior damage.
- The parameterisation of the input phase failure detection must be adapted => F6 Programming manual.

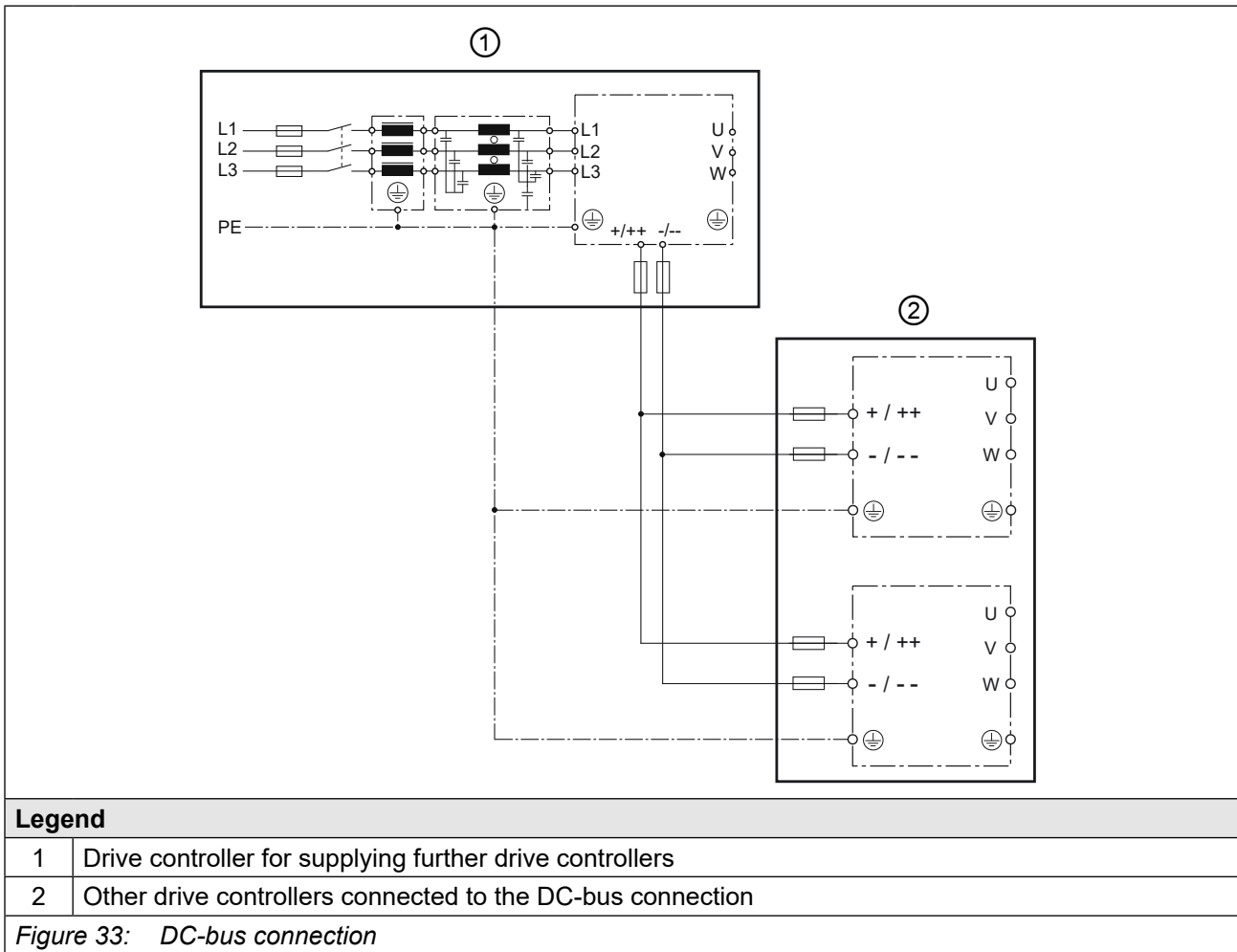

① When using this drive controller to supply other drive controllers via the DC terminals, the following must also be observed:

- The maximum prechargeable total capacity (internal capacity + external capacity) must not be exceeded => „Table 32: DC link / braking transistor function of the 400 V peak power devices“.
- The minimum waiting time between two precharging procedures must be observed => „5.2.1 Connection of the voltage supply“.
- Drive controllers supplied via the DC terminals must not be loaded during precharging.
- Overloading of the rectifier must be prevented by the user => „3.3.4 Overview of rectifier data for 400 V appliances“.

② When supplying this drive controller via the DC terminals, the following must also be observed:

- The drive controller must be pre-charged by the supplying drive controller or an external pre-charging module.

5.4 Accessories

5.4.1 Filters and chokes

Voltage class	Drive controller size	HF filter	Mains choke 50 Hz / 4% U_k
230 V	15	20E6T60-3000	15Z1B03-1000

Table 37: Filters and chokes for 230 V peak power devices

Voltage class	Drive controller size	HF filter	Mains choke 50 Hz / 4% U_k
400 V	17	18E6T60-1050 18E6T60-3000	17Z1B04-1000

Table 38: Filters and chokes for 400 V peak power devices



The specified filters and chokes are designed for rated operation.

5.4.2 Seal for IP54-ready devices

Name	Material number
Seal IP54	30F6T45-0004

Table 39: Seal for IP54-ready devices

5.4.3 Mounting kit shield connection brackets

Name	Material number
Mounting kit shield connection bracket control unit	00F6V80-2000
Mounting kit shield connection bracket power unit	00F6V80-3001

Table 40: Mounting kit shield connection bracket

5.4.4 Side-mounted braking resistors



Technical data and design about intrinsically safe braking resistors => https://www.keb.de/fileadmin/media/Manuals/dr/ma_dr_safe-braking-resistors-20106652_en.pdf



Technical data and design about non-intrinsically safe braking resistors => https://www.keb.de/fileadmin/media/Manuals/dr/ma_dr_braking-resistors-20116737_en.pdf



6 Approvals and certifications

6.1 CE-Marking

The drive converter marked with a CE logo comply with the requirements specified by European Union guidelines. The CE Declaration of Conformity is available on the Internet at <https://www.keb-automation.com/search>.



For further information regarding the CE declarations of conformity

=> „6.3 Further informations and documentation“

6.2 UL certification

	Acceptance according to UL is marked at KEB drive converter with the adjacent logo on the nameplate.	UL file number E167544
--	--	---------------------------

To be conform according to UL for use on the North American and Canadian Market the following additionally instructions must be observed (original text of the UL-File):

<ul style="list-style-type: none"> Maximum Surrounding Air Temperature: 45°C
<ul style="list-style-type: none"> Use 75°C Copper Conductors Only
<ul style="list-style-type: none"> All 480V ac / 3-ph Models: Suitable For Use On A Circuit Capable Of Delivering Not More Than 5000 rms Symmetrical Amperes, 480 Volts Maximum when protected by Class J Fuses, see instruction manual for Branch Circuit Protection details. Suitable For Use On A Circuit Capable Of Delivering Not More Than 30000 rms Symmetrical Amperes, 480 Volts Maximum when protected by Semiconductor Fuses by SIBA, Type 20 1xy 20.zz or by Bussmann, Type 170M1xyz or Littelfuse, Type L70QSzzz, see instruction manual for Branch Circuit Protection details. Note: “z”, “zz” or “zzz” replace the current rating for the respective type of fuse. “x” may represents different indicators and “y” may represents different fuse connection version. When DC supplied: Suitable For Use On A Circuit Capable Of Delivering Not More Than 50000 Amperes, 680 Volts DC Maximum when protected by Semiconductor Fuses as Specified in the manual.
<ul style="list-style-type: none"> All 200-240V ac / 3-ph Models: Suitable For Use On A Circuit Capable Of Delivering Not More Than 5000 rms Symmetrical Amperes, 240 Volts Maximum when protected by Class J Fuses, see instruction manual for Branch Circuit Protection details. Suitable For Use On A Circuit Capable Of Delivering Not More Than 30000 rms Symmetrical Amperes, 240 Volts Maximum when protected by Semiconductor Fuses by SIBA, Type 20 1xy 20.zz or by Bussmann, Type 170M1xyz or Littelfuse, Type L25S zzz, see instruction manual for Branch Circuit Protection details. CSA: For Canada, this marking shall be provided on the device or on a separate label shipped with the device. Note: “z”, “zz” or “zzz” replace the current rating for the respective type of fuse. “x” may represents different indicators and “y” may represents different fuse connection versions.

•	<p>Integral solid state short circuit protection does not provide branch circuit protection. Branch circuit protection must be provided in accordance with the Manufacturer Instructions, National Electrical Code and any additional local codes.</p> <p>CSA: For Canada: Integral solid state short circuit protection does not provide branch circuit protection. Branch circuit protection must be provided in accordance with the Canadian Electrical Code, Part I.</p>
•	Control Circuit Overcurrent Protection Required
•	<p>WARNING – The opening of the branch circuit protective device may be an indication that a fault current has been interrupted. To reduce the risk of fire or electrical shock, current-carrying parts and other components of the controller should be examined and replaced if damaged. If burnout of the current element of an overload relay occurs, the complete overload relay must be replaced.</p>
•	<p>All 480/277Vac / 3-ph models: Only for use in non-corner grounded type WYE source not exceeding 277 V phase to ground</p>
•	<p>Brake resistor ratings and duty cycle:</p> <ul style="list-style-type: none"> • Duty cycle 50% • Max. 60 sec on-time / 60 sec off-time
•	The required external control voltage supply shall be marked to indicate a 24Vdc supply voltage.
•	<p>For Use in a Pollution Degree 2 environment. For installations according to Canadian National Standard C22.2 No. 274-13: For use in Pollution Degree 2 and Overvoltage Category III environments only.</p>

6.3 Further informations and documentation

You find supplementary manuals and instructions for the download under www.keb-automation.com/search

General instructions

- EMC and safety instructions
- Manuals for additional control boards, safety modules, fieldbus modules, etc.

Instruction and information for construction and development

- Input fuses in accordance with UL
- Programming manual for control and power unit
- Motor configurator to select the appropriate drive controller and to create downloads for parameterizing the drive controller

Approvals and approbations

- Declaration of conformity CE
- TÜV certificate
- FS certification

Other markings and approvals not listed here are identified by a corresponding logo on the rating plate or device, if applicable. The corresponding certificates are available on our website.

Others

- COMBIVIS, the software for comfortable parameterization of drive controllers via PC (available per download)
- EPLAN drawings

7 Revision history

Version	Date	Description
00	2024-01	Creation of the pre-series version
01	2024-06	Including the 230 V peak power devices
02	2025-05	Description for DC-Ready devices included. UL certification updated. Series version completed.
03	2025-12	Recording of motor protection switches, values for input currents corrected.
04	2026-03	Editorial changes, description, glossary and standards updated.

Glossary

0V	Earth-potential-free common point	Encoder emulation	Software-generated encoder output
1ph	1-phase mains	End customer	The end customer is the user of the customer product
3ph	3-phase mains	Endat	Bidirectional encoder interface of the company Heidenhain
AC	AC current or voltage	EtherCAT	Real-time Ethernet bus system of the company Beckhoff
AFE	From 07/2019 AIC replaces the previous name AFE	Ethernet	Real-time bus system - defines protocols, plugs, types of cables
AFE filter	From 07/2019 AIC filter replaces the previous name AFE filter	FE	Functional earth
AIC	Active Infeed Converter	FSoE	Functional Safety over Ethernet
AIC filter	Filter for Active Infeed Converter	FU	Drive controller
Application	The application is the intended use of the KEB product	GND	Reference potential, ground
ASCL	Asynchronous sensorless closed loop	GTR7	Braking transistor
Auto motor ident.	Automatically motor identification; calibration of resistance and inductance	HF filter	KEB specific term for an EMC filter (for description see EMC filter).
AWG	American wire gauge	Hiperface	Bidirectional encoder interface of the company Sick-Stegmann
B2B	Business-to-business	HMI	Human machine interface (touch screen)
BiSS	Open source real-time interface for sensors and actuators (DIN 5008)	HSP5	Fast, serial protocol
CAN	Fieldbus system	HTL	Incremental signal with an output voltage (up to 30V) -> TTL
c.d.f.	Cyclic duration factor	IEC	IEC xxxxx stands for an international standard of the International Electrotechnical Commission
CDM	Complete drive module including auxiliary equipment (control cabinet)	IPxx	Protection class (xx for class)
COMBIVERT	KEB drive controller	KEB product	The KEB product is subject of this manual
COMBIVIS	KEB start-up and parameterizing software	KTY	Silicium temperature sensor (polarized)
Customer	The customer has purchased a KEB product from KEB and integrates the KEB product into his product (customer product) or resells the KEB product (dealer)	Manufacturer	The manufacturer is KEB, unless otherwise specified (e.g. as manufacturer of machines, engines, vehicles or adhesives)
DC	DC current or voltage	MCM	American unit for large wire cross sections
DI	Demineralized water, also referred to as deionized (DI) water	Modulation	Means in drive technology that the power semiconductors are controlled
DIN	German Institut for standardization	MTTF	Mean service life to failure
DS 402	CiA DS 402 - CAN device profile for drives	NHN	Standard elevation zero; based on the specified height definition in Germany (DHHN2016). The international data generally deviate from this by only a few cm to dm, so that the specified value can be applied to the regionally applicable definition.
ELV	Extra-low voltage	OC	Overcurrent
EMC filter	EMC filters are used to suppress conducted interferences in both directions between the drive controller and the mains	OH	Overheat
Emergency stop	Shutdown of a drive in emergency case (not de-energized)	OL	Overload
Emergency switching off	Switching off the voltage supply in emergency case		
EMS	Energy Management System		
EN	European standard		

OSSD	Output signal switching device; - an output signal that is checked in regular intervals on its shutdown. (safety technology)
PDS	Power drive system incl. motor and measuring probe
PE	Protective earth
PELV	Protective Extra Low Voltage
PFD	Term used in the safety technology (EN 61508-1...7) for the size of error probability
PFH	Term used in the safety technology (EN 61508-1...7) for the size of error probability per hour
PLC	Programmable logic controller
Pt100	Temperature sensor with $R_0=100\Omega$
Pt1000	Temperature sensor with $R_0=1000\Omega$
PTC	PTC-resistor for temperature detection
PWM	Pulse width modulation
RJ45	Modular connector with 8 lines
SCL	Synchronous sensorless closed loop
SELV	Safe extra-low voltage, unearthed
SIL	The safety integrity level is a measure for quantifying the risk reduction. Term used in the safety technology (EN 61508 -1...7)
SS1	Safety function „Safe stop 1“ in accordance with IEC 61800-5-2
SSI	Synchronous serial interface for encoder
STO	Safety function „Safe Torque Off“ in accordance with IEC 61800-5-2
TTL	Logic with 5 V operating voltage
USB	Universal serial bus
VARAN	Real-time Ethernet bus system

List of Figures

Figure 1:	Nameplate (exemplary).....	22
Figure 2:	Configurable options.....	23
Figure 3:	Switch-off time t depending on the overload I/IN (OL) for 230 V devices.....	31
Figure 4:	Typical overload characteristic in the lower output frequencies (OL2) example device size 15.....	32
Figure 5:	Switch-off time t depending on the overload I/IN (OL).....	39
Figure 6:	Typical overload characteristic in the lower output frequencies (OL2) example device size 17.....	40
Figure 7:	Block diagram of the energy flow.....	46
Figure 8:	Switching behaviour of the fans example heat sink fan.....	49
Figure 9:	Dimensions built-in version air cooler.....	50
Figure 10:	Dimensions push-through versions air cooler IP20, IP54-ready.....	51
Figure 11:	Mounting distances.....	53
Figure 12:	Installation of IP54-ready devices.....	54
Figure 13:	Control cabinet ventilation.....	55
Figure 14:	Airflow of the drive controller.....	55
Figure 15:	F6 housing 3 top view.....	56
Figure 16:	F6 housing 3 front view.....	57
Figure 17:	F6 housing 3 rear view with control board APPLICATION.....	58
Figure 18:	Input circuit.....	59
Figure 19:	Terminal block X1A.....	60
Figure 20:	Connection for protective earth.....	61
Figure 21:	Connection of the mains supply 3-phase.....	62
Figure 22:	Terminal block X1A DC connection.....	64
Figure 23:	Connection at DC voltage supply.....	65
Figure 24:	Wiring of the motor.....	66
Figure 25:	Terminal block X1A motor connection.....	67
Figure 26:	Symmetrical motor line.....	68
Figure 27:	Terminal block X1C for control board APPLICATION and COMPACT.....	70
Figure 28:	Terminal block X1C for control board PRO.....	70
Figure 29:	Connection of the brake control.....	71
Figure 30:	Connection of a KTY sensor.....	71
Figure 31:	Terminal block X1A connection braking resistor.....	73
Figure 32:	Wiring of an intrinsically safe braking resistor.....	74
Figure 33:	DC-bus connection.....	76

List of Tables

Table 1:	Part code.....	21
Table 2:	Climatic environmental conditions	24
Table 3:	Mechanical environmental conditions	25
Table 4:	Further environmental operating conditions.....	25
Table 5:	Device classification.....	26
Table 6:	Electromagnetic compatibility	26
Table 7:	Overview of the 230 V peak power device data	28
Table 8:	Input voltages and frequencies of the 230V devices	28
Table 9:	DC link voltage for 230V devices	28
Table 10:	Output voltages and frequencies of the 230V devices	29
Table 11:	Example of the calculation of the possible motor voltage 230V	29
Table 12:	Input and output currents of the 230 V peak power devices.....	29
Table 13:	Frequency-dependent maximum current for device size 15	33
Table 14:	Power dissipation of the 230V peak power devices	34
Table 15:	Fusings of the 230 V peak power devices.....	34
Table 16:	Overview of the 400V Peak Power device data.....	36
Table 17:	Input voltages and frequencies of the 400V devices	36
Table 18:	DC link voltage for 400V devices	36
Table 19:	Output voltages and frequencies of the 400V devices	37
Table 20:	Example of the calculation of the possible motor voltage:.....	37
Table 21:	Input and output currents of the 400 V peak power devices.....	37
Table 22:	Frequency-dependent maximum current for device size 17	41
Table 23:	Overview of rectifier data for 400 V appliances	41
Table 24:	Power dissipation of the 400 V Peak Power devices.....	42
Table 25:	Fusings of the 400 V peak power devices	42
Table 26:	DC-Fusing of the 400 V / 480V devices	43
Table 27:	Recommended motor protection switches/circuit breakers for 400 V/480 V devices	44
Table 28:	Recommended motor protection switches/circuit breakers for 400 V/480 V devices	44
Table 29:	Switching frequency and temperature of the 230 V peak power devices	45
Table 30:	Switching frequency and temperature of the 400 V peak power devices	45
Table 31:	DC link / braking transistor function of the 230V peak power devices	47
Table 32:	DC link / braking transistor function of the 400V peak power devices	48
Table 33:	Fan.....	48
Table 34:	Switching points of the fans	49
Table 35:	Mounting instructions for built-in version.....	52
Table 36:	Fastening instructions for push-through version	52
Table 37:	Filters and chokes for 230V peak power devices	77
Table 38:	Filters and chokes for 400V peak power devices	77
Table 39:	Seal for IP54-ready devices.....	77
Table 40:	Mounting kit shield connection bracket.....	77



MORE KEB PARTNERS WORLDWIDE:

www.keb-automation.com/contact





Automation with Drive

www.keb-automation.com

KEB Automation KG Suedstrasse 38 D-32683 Barntrop Tel. +49 5263 401-0 E-Mail: info@keb.de