



COMBIVERT S6

INSTRUCTIONS FOR USE | INSTALLATION S6 HOUSING 2

Translation of the original manual
Document 20088319 EN 17



Preface

The hardware and software described in this document are products of KEB. The information contained in this document is valid at the time of publishing. KEB reserves the right to update this document in response to misprints, mistakes or technical changes.

Signal words and symbols

Certain procedures within this document can cause safety hazards during the installation or operation of the device. Refer to the safety warnings in this document when performing these procedures. Safety signs are also located on the device where applicable. A safety warning is marked by one of the following warning signs:

DANGER	Dangerous situation, which will cause death or serious injury if this safety warning is ignored.
WARNING	Dangerous situation, which may cause death or serious injury if this safety warning is ignored.
CAUTION	Dangerous situation, which may cause minor injury if this safety warning is ignored.
NOTICE	Situation, which can cause damage to property if this safety warning is ignored.

RESTRICTION

Used when the following statements depend on certain conditions or are only valid for certain ranges of values.



Used for informational messages or recommended procedures.

More symbols

- ▶ This arrow starts an action step.
- / - Enumerations are marked with dots or indents.
- => Cross reference to another chapter or another page.



Note to further documentation.
<https://www.keb-automation.com/search>



Laws and guidelines

KEB Automation KG confirms with the EC declaration of conformity and the CE mark on the device nameplate that it complies with the essential safety requirements.

The EC declaration of conformity can be downloaded on demand via our website.

Warranty and liability

The warranty and liability on design, material or workmanship for the acquired device is given in the general sales conditions.



Here you will find our general sales conditions.

<https://www.keb-automation.com/terms-conditions>



Further agreements or specifications require a written confirmation.

Support

Although multiple applications are referenced, not every case has been taking into account. If you require further information or if problems occur which are not referenced in the documentation, you can request the necessary information via the local KEB agency.

The use of our units in the target products is outside of our control and therefore lies exclusively in the area of responsibility of the customer.

The information contained in the technical documentation, as well as any user-specific advice in spoken and written and through tests, are made to best of our knowledge and information about the intended use. However, they are regarded as being only informal and changes are expressly reserved, in particular due to technical changes. This also applies to any violation of industrial property rights of a third-party. Selection of our units in view of their suitability for the intended use must be done generally by the user.

Tests can only be done within the intended end use of the product (application) by the customer. They must be repeated, even if only parts of hardware, software or the unit adjustment are modified.

Copyright

The customer may use the instructions for use as well as further documents or parts from it for internal purposes. Copyrights are with KEB and remain valid in its entirety.

This KEB product or parts thereof may contain third-party software, including free and/or open source software. If applicable, the license terms of this software are contained in the instructions for use. The instructions for use are already available to you, can be downloaded free of charge from the KEB website or can be requested from the respective KEB contact person.

Other wordmarks or/and logos are trademarks (™) or registered trademarks (®) of their respective owners.

Table of Contents

Preface	3
Signal words and symbols	3
More symbols.....	3
Laws and guidelines.....	4
Warranty and liability.....	4
Support	4
Copyright.....	4
Table of Contents	5
1 Basic Safety Instructions	9
1.1 Target group.....	9
1.2 Transport, storage and proper use.....	10
1.3 Installation.....	11
1.4 Electrical connection	12
1.4.1 EMC-compatible installation.....	13
1.4.2 Voltage test.....	13
1.4.3 Insulation measurement.....	13
1.5 Start-up and operation.....	14
1.6 Maintenance.....	16
1.7 Repair	16
1.8 Disposal.....	17
2 Product description	18
2.1 Specified application.....	18
2.1.1 Residual risks	18
2.2 Unintended use.....	18
2.3 Product features	19
2.4 Type code	20
2.5 Nameplate	21
2.5.1 Configurable options	22
3 Technical data	23
3.1 Operating conditions	23
3.1.1 Climatic environmental conditions.....	23
3.1.2 Mechanical environmental conditions	24
3.1.3 Chemical / mechanical active substances.....	24
3.1.4 Electrical operating conditions.....	25
3.1.4.1 Device classification	25
3.1.4.2 Electromagnetic compatibility.....	25

3.2 Dimensions and weights	26
3.2.1 Built-in version.....	26
3.2.2 Built-in version with accessories	27
3.2.3 Control cabinet installation	28
3.3 Mounting instructions for control cabinet installation	29
3.3.1 Installation depth	30
3.4 Device data of the 400 V devices	31
3.4.1 Overview of the 400 V devices	31
3.4.2 Rated operation.....	31
3.4.3 Voltage and frequency specifications of the 400 V devices	32
3.4.3.1 Example for the calculation of the motor voltage	32
3.4.4 Input and output currents / overload of the 400 V devices	33
3.4.5 Overview of rectifier data for 400 V devices.....	33
3.4.6 Power loss during rated operation of 400 V devices	34
3.5 Device data of the 230 V devices	35
3.5.1 Overview of the 230 V devices	35
3.5.2 Rated operation.....	35
3.5.3 Voltage and frequency specifications of the 230 V devices	36
3.5.4 Input and output currents / overload of the 230 V devices	37
3.5.5 Power loss during rated operation of 230 V devices	37
3.6 General data.....	38
3.6.1 Overload characteristic (OL)	38
3.6.1.1 Switch-off time depending on the overload at 400V devices	39
3.6.1.2 Switch-off time depending on the overload at 230V devices	40
3.6.1.3 Maximum current (OL2)	41
3.6.2 Switching frequency and temperature.....	44
3.6.3 Fusing of the drive controllers	45
3.6.3.1 Protection of 400 V devices with AC supply, 3-phase	45
3.6.3.2 Fuse protection of 230 V devices with AC supply, 1-phase.....	45
3.6.3.3 Protection of 400 V devices with DC supply.....	46
3.6.3.4 Motor-protective circuit-breakers / circuit-breakers	47
3.6.4 DC link / braking transistor function.....	49
3.6.4.1 DC link / braking transistor function of the 400 V devices	49
3.6.4.2 DC link / braking transistor function of the 230V devices	49
3.6.5 DC link / braking transistor function.....	50
3.6.6 Fan	51
3.6.6.1 Switching behaviour of the fan	51
3.6.6.2 Switching points of the fan	51

4 Installation and connection	52
4.1 Overview of the COMBIVERT S6.....	52
4.2 Connection of the power unit.....	54
4.2.1 Connection of the voltage supply	54
4.2.1.1 230V devices	54
4.2.1.2 Mains terminal block X1A.....	55
4.2.2 Leakage currents.....	56
4.2.3 Protective und functional earth.....	56
4.2.3.1 Protective earth	56
4.2.3.2 Functional earthing.....	57
4.2.4 AC mains connection.....	58
4.2.4.1 AC supply 230V/400V 3-phase.....	58
4.2.4.2 AC supply 230V 1-phase	59
4.2.4.3 Supply cable.....	60
4.2.5 DC mains connection	60
4.2.5.1 DC supply.....	60
4.2.5.2 Terminal block X1B DC connection	61
4.2.6 DC-bus connection.....	61
4.2.7 Connection of the motor.....	63
4.2.7.1 Selection of the motor cable.....	63
4.2.7.2 Conducted immunity depending on the motor cable length at AC supply.....	63
4.2.7.3 Motor cable length at operation with DC voltage.....	63
4.2.7.4 Motor cable length for parallel operation of motors	64
4.2.7.5 Motor cable cross-section	64
4.2.7.6 Interconnection of the motor.....	64
4.2.7.7 Terminal block X1B motor connection	64
4.2.7.8 Wiring of the motor	65
4.2.8 Connection of a braking resistor.....	66
4.2.8.1 Terminal block X1B connection braking resistor.....	66
4.2.8.2 Use of intrinsically safe braking resistors	67
4.2.8.3 Use of non-intrinsically safe braking resistors	67
4.3 Brake control and temperature detection for K- and A- control	68
4.3.1 Specification and connection of the brake control.....	68
4.3.2 Specification and connection of the temperature detection.....	69
4.3.3 Operation without temperature detection	70
4.3.4 Connection of a KTY sensor	70
4.3.5 Connection of PTC, temperature switch or PT1000.....	71

4.4 Brake control and temperature detection for P- control.....	72
4.4.1 Specification and connection of the brake / relay control.....	72
4.4.2 Specification and connection of the temperature detection.....	73
4.4.2.1 Operation without temperature detection.....	74
4.4.2.2 Connection of a KTY sensor.....	74
4.4.2.3 Connection of PTC, temperature switch or PT1000.....	75
5 Certification.....	76
5.1 CE marking.....	76
5.2 Functional safety.....	76
5.3 Annex to the declaration of conformity.....	76
5.4 UL Marking.....	78
5.5 Further informations and documentation.....	81
6 Revision history.....	82
Glossary.....	83
List of Figures.....	85
List of Tables.....	86

1 Basic Safety Instructions

The products are designed and constructed in accordance with state-of-the-art technology and the recognized safety rules and regulations. However, the use of such devices may cause functional hazards for life and limb of the user or third parties, or damages to the system and other material property.

The following safety instructions have been created by the manufacturer for the area of electric drive technology. They can be supplemented by local, country- or application-specific safety instructions. This list is not exhaustive. Violation of the safety instructions by the customer, user or other third party leads to the loss of all resulting claims against the manufacturer.

NOTICE



Hazards and risks through ignorance!

- ▶ Read the instructions for use!
- ▶ Observe the safety and warning instructions!
- ▶ If anything is unclear, please contact KEB Automation KG!

1.1 Target group

This instruction manual is determined exclusively for electrical personnel. Electrical personnel for the purpose of this instruction manual must have the following qualifications:

- Knowledge and understanding of the safety instructions.
- Skills for installation and assembly.
- Start-up and operation of the product.
- Understanding of the function in the used machine.
- Detection of hazards and risks of the electrical drive technology.
- Knowledge of *VDE 0100*.
- Knowledge of national safety regulations.
-

⚠ DANGER



Interventions by unauthorized personnel!

Danger to life by electric shock and malfunction!

- ▶ Modification or repair is only permitted by KEB authorised personnel.

1.2 Transport, storage and proper use

The transport is carried out by qualified persons in accordance with the environmental conditions specified in this manual. Drive controller shall be protected against excessive strains.



Transport of drive controllers with an edge length >75 cm

The transport by forklift without suitable tools can cause a deflection of the heat sink. This leads to premature aging or destruction of internal components.

- ▶ Transport of drive controllers on suitable pallets.
 - ▶ Do not stack drive controllers or burden them with other heavy objects.
-

NOTICE

Damage to the coolant connections

Bending of the tubes!

- ▶ Never place the device on the coolant connections
-

NOTICE

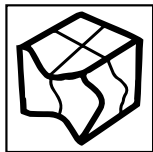

Behaviour in case of transport damage

- ▶ When receiving goods, check the device for transport damage such as deformations or loose parts.
 - ▶ In case of damage, contact the carrier immediately.
 - ▶ Do not operate the device in case of transport damage!
-



Drive controllers contain electrostatic sensitive components.

- ▶ Avoid contact.
 - ▶ Wear ESD-protective clothing.
-

Do not store drive controllers

- in the environment of aggressive and/or conductive liquids or gases.
- with direct sunlight.
- outside the specified environmental conditions.

1.3 Installation

⚠ DANGER**Do not operate in an explosive environment!**

- ▶ The product is not intended for the use in potentially explosive environment.

⚠ CAUTION**Design-related edges and high weight!****Contusions and bruises!**

- ▶ Never stand under suspended loads.
- ▶ Wear safety shoes.
- ▶ Secure drive controller accordingly when using lifting gear.

To prevent damages to the device:

- Make sure that no components are bent and/or isolation distances are changed.
- The device must not be put into operation in case of mechanical defects.
- Do not allow moisture or mist to penetrate the unit.
- Avoid dust permeating the device. Allow for sufficient heat dissipation if installed in a dust-proof housing.
- Note installation position and minimum distances to surrounding elements. Do not cover the ventilation openings.
- Mount the drive controller according to the specified degree of protection.
- Make sure that no small parts fall into the product during assembly and wiring (drilling chips, screws etc.). This also applies to mechanical components, which can lose small parts during operation.
- Check the reliable fit of the device connections in order to avoid contact resistances and sparking.
- Do not walk-on drive controller.
- Follow all safety instructions!

1.4 Electrical connection

⚠ DANGER



Voltage at the terminals and in the device !

Danger to life due to electric shock !

- ▶ Never work on the open device or never touch exposed parts.
- ▶ For any work on the unit switch off the supply voltage, secure it against switching on and check absence of voltage by measuring at the input terminals.
- ▶ Wait until all drives has been stopped in order that no regenerative energy can be generated.
- ▶ Await capacitor discharge time (5 minutes). Check absence of voltage by measuring at the terminal block.
- ▶ If personal protection is required, install suitable protective devices for drive converters.
- ▶ Never bridge upstream protective devices (even for testing purposes).
- ▶ Connect the protective earth conductor always to drive converter and motor.
- ▶ Install all required covers and protective devices for operation.
- ▶ The control cabinet shall be kept closed during operation.
- ▶ Residual current: This product may cause a dc current in the protective earth conductor. When a residual current protective device (RCD) or a residual current monitoring device (RCM) is used for the protection against direct or indirect contact, only a RCD or RCM type B is permitted on the power supply side of this product.
- ▶ Drive converters with a leakage current $> 3.5\text{mA AC}$ current (10mA DC current) are intended for a stationary connection. Protective earth conductors must be designed in accordance with the local regulations for equipment with high leakage currents according to *EN 61800-5-1*, *EN 60204-1* or *VDE 0100*.



If personnel protection is required during installation of the system, suitable protective devices must be used for drive controllers.

www.keb.de/fileadmin/media/Techinfo/dr/tn/ti_dr_tn-rcd-00008_en.pdf



Installations which include drive controller shall be equipped with additional control and protective devices in accordance with the relevant applicable safety requirements, e.g. act respecting technical equipment, accident prevention rules etc. They must always be complied with, also for drive controller bearing a CE marking.

For a trouble-free and safe operation, please pay attention to the following instructions:

- The electrical installation shall be carried out in accordance with the relevant requirements.
- Cable cross-sections and fuses must be dimensioned by the user according to the specified minimum/maximum values for the application.
- Connection of the drive converter is only permissible on symmetrical networks with a maximum line voltage (L1, L2, L3) with respect to earth (N/PE) of max. 300 V.
- With existing or newly wired circuits the person installing the units or machines must ensure that the PELV requirements are met.
- For drive converters that are not isolated from the supply circuit (in accordance with *EN 60721-3-2*) all control lines must be included in other protective measures (e.g. double insulation or shielded, earthed and insulated).
- When using components without isolated inputs/outputs, it is necessary that equipotential bonding exists between the components to be connected (e.g. by the equipotential line). Disregard can cause destruction of the components by equalizing currents.

1.4.1 EMC-compatible installation

Observance of the limit values required by EMC law is the responsibility of the customer.



Notes on EMC-compatible installation can be found here.

www.keb.de/fileadmin/media/Manuals/dr/emv/0000neb0000.pdf



1.4.2 Voltage test

Testing with AC voltage (in accordance with *EN 60204-1* chapter 18.4) may not be executed, since there is danger for the power semiconductors in the drive controller.



Due to the radio interference suppression capacitors, the test generator will switch off immediately with a current fault.



According to *EN 60204-1* it is permissible to disconnect already tested components. Drive controllers of the KEB Automation KG are delivered ex works voltage tested to 100% according to product standard.

1.4.3 Insulation measurement

An insulation measurement (in accordance with *EN 60204-1* chapter 18.3) with DC 500 V is permissible, if all power unit connections (grid-connected potential) and all control connections are bridged with PE. The insulation resistance of the respective device can be found in the technical data.

1.5 Start-up and operation

The start-up (i.e. for the specified application) is forbidden until it is determined that the installation complies with the machine directive; account is to be taken of [EN 60204-1](#).

⚠ WARNING

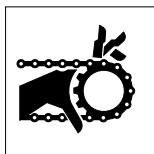

Software protection and programming!

Hazards caused by unintentional behavior of the drive!

- ▶ Check especially during initial start-up or replacement of the drive controller if parameterization is compatible to application.
- ▶ Securing a unit solely with software-supported functions is not sufficient. It is imperative to install external protective measures (e.g. limit switch) that are independent of the drive controller.
- ▶ Secure motors against automatic restart.

⚠ CAUTION



High temperatures at heat sink and coolant!

Burning of the skin!

- ▶ Cover hot surfaces safe-to-touch.
- ▶ If necessary, attach warning signs on the system.
- ▶ Before touching, check the surface and coolant lines.
- ▶ Before working let the unit cool down.

- During operation, all covers and doors shall be kept closed.
- Use only approved accessories for this device.
- Never touch terminals, busbars or cable ends.

⚠ WARNING



Triggering of overcurrent protection devices

Risk of fire or electric shock!

- ▶ Triggering of an overcurrent protection device will be a hint for an overload or short circuit. Triggering a RCD may be caused by a leakage current.
- ▶ In order to reduce the risk of fire or electric shock, live parts and other components of the controller should be checked and replaced in case of damage.
- ▶ If the contacts of an overload relay are burned, the complete relay must be replaced.

⚠ CAUTION

High sound level during operation!

Hearing damage possible!

- ▶ Wear hearing protection!

NOTICE

Continuous operation (S1) with load > 60% or from a rated motor power of 55kW!

Premature ageing of the electrolytic capacitors!

- ▶ Mains choke with $U_k = 4\%$ absolutely necessary.



If a drive controller with electrolytic capacitors in a DC link has not been in operation for more than one year, observe the following instructions.

www.keb.de/fileadmin/media/Techinfo/dr/tn/ti_dr_tn-format-capacitors-00009_en.pdf

**Switching at the output**

Switching between motor and drive controller is prohibited for single drives during operation as this may trigger the protection gear of the device. Function 'speed search' must be activated if switching can not be avoided. Speed search may only be triggered after closing the motor contactor (e.g. by switching the control release).

Connecting and disconnecting is permissible with multiple motor drives if at least 1 motor is running during the switch-over process. The drive controller must be dimensioned to the occurring starting currents.

The 'speed search' function must be activated if the motor is still running during a restart of the drive controller (mains on) (e.g. due to large rotating masses).

Switching at the input

For applications that require cyclic switching off and on of the drive controller, maintain an off-time of at least 5 min after the last switch on. If you require shorter cycle times please contact KEB Automation KG.

Short-circuit resistance

The drive converters are conditional short-circuit proof. After resetting the internal protection devices, the function as directed is guaranteed.

Exceptions:

- If an earth-leakage fault or short-circuit often occurs at the output, this can lead to a defect in the unit.
- If a short-circuit occurs during regenerative operation (2nd or 4th quadrant, regeneration into the DC link), this can lead to a defect in the unit.

1.6 Maintenance

The following maintenance work has to be carried out when required, but at least once per year by authorized and trained personnel. Check unit for loose screws and plugs and tighten if necessary.

- ▶ Check system for loose screws and plugs and tighten if necessary.
- ▶ Clean drive controller from dirt and dust deposits. Pay attention especially to cooling fins and protective grid of the fans.
- ▶ Examine and clean extracted air filter and cooling air filter of the control cabinet.
- ▶ Check the function of the fans of the drive controller. The fan must be replaced in case of audible vibrations or squeak.
- ▶ In the case of liquid-cooled drive controllers a visual test of the cooling circuit for leaks and corrosion must be carried out. The cooling circuit must be completely empty if a unit shall be switched off for a longer period. The cooling circuit must be blown out additionally with compressed air at temperatures below 0°C.

1.7 Repair

In case of malfunction, unusual noises or smells inform a person in charge!

⚠ DANGER



Unauthorized exchange, repair and modifications!

Unpredictable malfunctions!

- ▶ The function of the drive controller is dependent on its parameterization. Never replace without knowledge of the application.
- ▶ Modification or repair is permitted only by KEB Automation KG authorized personnel.
- ▶ Only use original manufacturer parts.
- ▶ Infringement will annul the liability for resulting consequences.

In case of failure, please contact the machine manufacturer. Only the machine manufacturer knows the parameterisation of the used drive controller and can provide an appropriate replacement or induce the maintenance.

1.8 Disposal

Electronic devices of the KEB Automation KG are exclusively professional devices for further industrial processing (so-called B2B devices).

Manufacturers of B2B devices are obliged to take back and recycle devices manufactured after 14.08.2018. These devices may not be disposed at the collection centres of public sector disposal organisations.

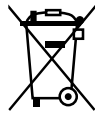

If no deviating agreement has been made between the customer and KEB or no deviating mandatory legal regulation exists, KEB products marked in this way can be returned. Company and keyword to the return point can be taken from the list below. Shipping costs are paid by the customer. Thereupon the devices will be professionally recycled and disposed.

The entry numbers are listed country-specific in the following table. The corresponding KEB return addresses can be found on our website.

Withdrawal by	WEEE-Reg.-No.	Keyword
Austria		
KEB Automation GmbH	ERA: 51976	Stichwort „Rücknahme WEEE“
France		
RÉCYLUM - Recycle point	ADEME: FR021806	Mots clés „KEB DEEE“
Germany		
KEB Automation KG	EAR: DE12653519	Stichwort „Rücknahme WEEE“
Italy		
COBAT	AEE: (IT) 19030000011216	Parola chiave „Ritiro RAEE“
Spain		
KEB Automation KG	RII-AEE 7427	Palabra clave „Retirada RAEE“
Česko		
KEB Automation KG	RETELA 09281/20 ECZ	Klíčové slovo: Zpětný odběr OEEZ
Slowakei		
KEB Automation KG	ASEKOL: RV22EEZ0000421	Klíčové slovo: "Spätný odber OEEZ"

The packaging must be feed to paper and cardboard recycling.

2 Product description

The drive controller series COMBIVERT S6 is optimised for the operation at synchronous and asynchronous motors. The integrated safety function STO has been developed for the use in safety-oriented applications.

The COMBIVERT meets the requirements of the Low-Voltage Directive. Die harmonisierten Normen der Reihe [EN 61800-5-1](#) für Antriebsstromrichter werden angewendet.

Der COMBIVERT ist ein Produkt mit eingeschränkter Erhältlichkeit nach [EN 61800-3](#). This product may cause radio interference in residential areas. In this case the operator may need to take corresponding measures.

The machine directive, EMC directive, Low Voltage Directive and other guidelines and regulations must be observed depending on the version.

2.1 Specified application

The COMBIVERT serves exclusively for the control and regulation of three-phase motors. It is intended for the installation into electrical systems or machines.

Technical data and information for connection conditions shall be taken from the type plate and from the instruction manual and must be strictly observed.

The used semiconductors and components of the KEB Automation KG are developed and dimensioned for the use in industrial products.

Restriction

If the product is used in machines, which work under exceptional conditions or if essential functions, life-supporting measures or an extraordinary safety step must be fulfilled, the necessary reliability and security must be ensured by the machine builder.

2.1.1 Residual risks

Despite intended use, the drive controller can reach unexpected operating conditions in case of error, with wrong parameterisation, by faulty connection or unprofessional interventions and repairs. This can be:

- wrong direction of rotation
- motor speed too high
- motor is running into limitation
- motor can be under voltage even in standstill
- automatic start

2.2 Unintended use

The operation of other electric consumers is prohibited and can lead to the destruction of the devices. The operation of our products outside the indicated limit values of the technical data leads to the loss of any liability claims.

2.3 Product features

This instruction manual describes the power circuits of the following devices:

Device type:	Drive controller
Series:	COMBIVERT S6
Power range:	0.75...2.2 kW 400 V 3-phase 0.75...1.5 kW 230 V 1-phase
Housing:	2

The COMBIVERT S6 is characterised by the following features:

- For asynchronous, synchronous, IPM or synchronous reluctance motors
- With encoder or encoderless SCL and ASCL for accurate speed control
- Motor temperature monitoring PTC, KTY or PT1000
- Two-channel multi-encoder interface
- Integrated braking transistor
- Integrated brake control
- Integrated safety functionality
- Basic function STO in the compact version
- Additional high level safety in the application version
- Real-time Ethernet interfaces
- Following fieldbus systems are supported directly at S6:
CAN, VARAN
- RS232/485 for diagnosis or display
- Book format for space-saving control cabinet construction
- Direct mains connection for 230 V and 400 V mains, alternatively also DC input 260...750 V
- Low leakage current mains filter (<5 mA) integrated, optional without filter
- High overload for best dynamics
- Supports existing machine concepts with 8 digital and 2 analog inputs, 2 digital outputs + 1 relay and 1 analog output 0...10 V



Due to the wide voltage range, the 3-phase 400V devices can also be operated at 230V applications, => „5.4 UL Marking“.

2.4 Type code

xx	S6	x	x	x-x	x	x	x
Reserved		0: Reserved					
Reserved		0: Reserved					
Type of control		COMPACT 1: Multi Encoder Interface, EtherCAT ¹⁾ 2: Multi Encoder Interface, VARAN APPLICATION 1: Realtime Ethernet Module, Multi Encoder Interface B: Multi Encoder Interface, CAN®, Realtime Ethernet Module, alternative terminal strip PRO 3: Multi encoder interface, RS485 potential-free, Ethernet (no node switch) 4: no encoder, Ethernet fieldbus interface, safe relay 5: Multi encoder interface, Ethernet fieldbus interface, safe relay					
Version power unit		1: AC 480V 3-phase with HF filter 2: AC 480V 3-phase without HF filter ²⁾ 3: AC 230V 1-phase with HF filter 4: AC 230V 1-phase without HF filter ²⁾					
Housing		2, 4					
Safety module		1: Type 1 for Strg A (STO/SBC) or STO for Strg K 3: Type 3 for Strg A (STO/SBC/SLS etc.) 5: Type 5 STO / SLS / etc. FSOE					
Control type		A: APPLICATION K: COMPACT P: PRO					
Series		COMBIVERT S6					
Device size		07...14 ³⁾					

Table 1: Type code

¹⁾  EtherCAT® is a registered trademark and patented technology licensed by the company Beckhoff Automation GmbH, Germany.

²⁾ An external filter is required for this devices in order to comply with the limit values according to EN 61800-3.

³⁾ Device size 14 is only available in the version without integrated HF filter.



The type code is not used as order code, but only for identification!

2.5 Nameplate

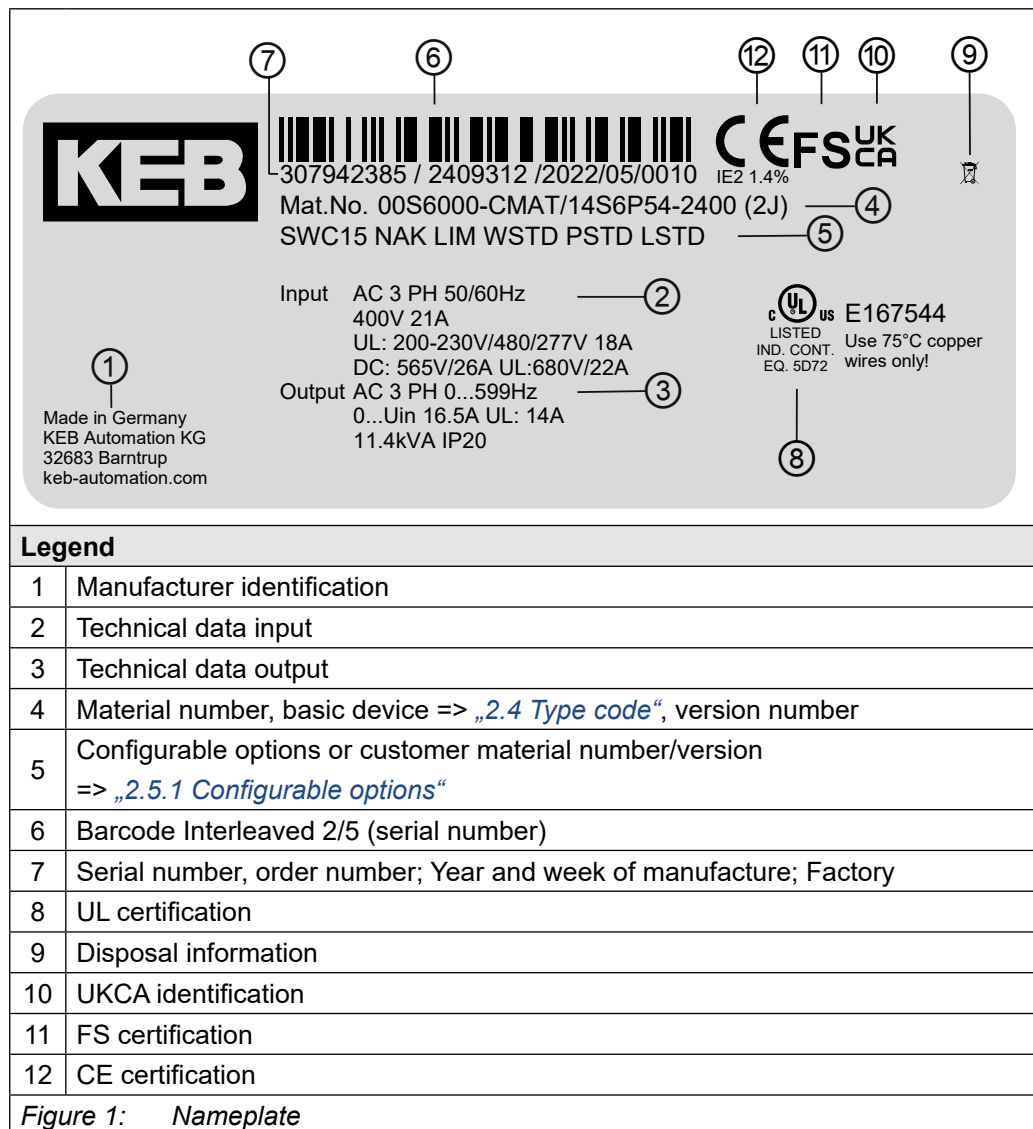

2.5.1 Configurable options

Features	Feature values	Description
Software	SWxxx ¹⁾	Software version of the drive controller
Accessories	Axxx ¹⁾	Selected accessories
	NAK	No accessories
Clearing output frequency	LIM	Limitation to 599 Hz
	ULO	> 599 Hz available
Warranty	WSTD	Warranty - standard
	Wxxx ¹⁾	Warranty extension
Parameterisation	PSTD	Parameterisation - standard
	Pxxx ¹⁾	Parameterisation - customer-specific
Nameplate logo	LSTD	Logo - standard
	Lxxx ¹⁾	Logo - customer-specific
<i>Table 2: Configurable options</i>		

¹⁾ "x" stands for a variable value.

3 Technical data

Unless otherwise indicated, all electrical data in the following chapter refer to a 3-phase AC mains.

3.1 Operating conditions

3.1.1 Climatic environmental conditions

Storage	Standard	Class	Descriptions
Ambient temperature	EN 60721-3-1	1K4	-25...55 °C
Relative humidity	EN 60721-3-1	1K3	5...95 % (without condensation)
Storage height	–	–	Max. 3000 m above sea level
Transport	Standard	Class	Descriptions
Ambient temperature	EN 60721-3-2	2K3	-25...70 °C
Relative humidity	EN 60721-3-2	2K3	95 % at 40 °C (without condensation)
Operation	Standard	Class	Descriptions
Ambient temperature	EN 60721-3-3	3K3	5...40 °C (extended to -10...45 °C)
Coolant inlet temperature	–	–	5...40 °C (-10...45 °C)
Relative humidity	EN 60721-3-3	3K3	5...85 % (without condensation)
Version and degree of protection	EN 60529	IP20	Protection against foreign material > ø12.5 mm No protection against water Non-conductive pollution, occasional condensation when PDS is out of service.
Site altitude	–	–	Max. 2000 m above sea level <ul style="list-style-type: none"> • With site altitudes over 1000 m a derating of 1 % per 100 m must be taken into consideration. • With site altitudes over 2000 m, the control board to the mains has only basic isolation. Additional measures must be taken when wiring the control.

Table 3: Climatic environmental conditions

3.1.2 Mechanical environmental conditions

Storage	Standard	Class	Descriptions
Vibration limits	EN 60721-3-1	1M2	Vibration amplitude 1.5 mm (2...9 Hz) Acceleration amplitude 5 m/s ² (9...200 Hz)
Shock limit values	EN 60721-3-1	1M2	40 m/s ² ; 22 ms
Transport	Standard	Class	Descriptions
Vibration limits	EN 60721-3-2	2M1	Vibration amplitude 3.5 mm (2...9 Hz) Acceleration amplitude 10 m/s ² (9...200 Hz) (Acceleration amplitude 15 m/s ² (200...500 Hz)) ¹⁾
Shock limit values	EN 60721-3-2	2M1	100 m/s ² ; 11 ms
Operation	Standard	Class	Descriptions
Vibration limits	EN 60721-3-3	3M4	Vibration amplitude 3.0 mm (2...9 Hz) Acceleration amplitude 10 m/s ² (9...200 Hz)
	EN 61800-5-1	–	Vibration amplitude 0.075 mm (10...57 Hz) Acceleration amplitude 10 m/s ² (57...150 Hz)
Shock limit values	EN 60721-3-3	3M4	100 m/s ² ; 11 ms

Table 4: Mechanical environmental conditions

¹⁾ Not tested.

3.1.3 Chemical / mechanical active substances

Storage	Standard	Class	Descriptions	
Contamination	EN 60721-3-11	Gases	1C2	–
		Solids	1S2	–
Transport	Standard	Class	Descriptions	
Contamination	EN 60721-3-22	Gases	2C2	–
		Solids	2S2	–
Operation	Standard	Class	Descriptions	
Contamination	EN 60721-3-3	Gases	3C2	–
		Solids	3S2	–

Table 5: Chemical / mechanical active substances

3.1.4 Electrical operating conditions

3.1.4.1 Device classification

Requirement	Standard	Class	Descriptions
Overvoltage category	EN 61800-5-1	III	–
	EN 60664-1		–
Pollution degree	EN 60664-1	2	Non-conductive pollution, occasional condensation when PDS is out of service

Table 6: Device classification

3.1.4.2 Electromagnetic compatibility

An external filter is required for devices without an internal filter in order to comply with the following limits.

EMC emitted interference	Standard	Class	Descriptions
Conducted interference emissions	EN 61800-3	C2/C3	The specified value is only achieved in connection with a filter. Information on interference suppression (max. switching frequency, cable length) can be found in the corresponding filter instructions.
Radiated interferences	EN 61800-3	C2	–
Interference immunity	Standard	Level	Descriptions
Static discharges	EN 61000-4-2	8 kV	AD (air discharge)
		4 kV	CD (contact discharge)
Burst - Ports for process measurement control lines and signal interfaces	EN 61000-4-4	2 kV	–
Burst - Power ports	EN 61000-4-4	4 kV	–
Surge - Power ports	EN 61000-4-5	1 kV	Phase-phase
		2 kV	Phase-ground
Conducted immunity, induced by radio-frequency fields	EN 61000-4-6	10 V	0.15...80 MHz
Electromagnetic fields	EN 61000-4-3	10 V/m	80 MHz...1 GHz
		3 V/m	1.4...2 GHz
		1 V/m	2...2.7 GHz
Voltage fluctuations/ voltage dips	EN 61000-2-1 EN 61000-4-34	–	-15 %...+10 % 90 %
		–	≤ 2 %
Frequency changes	EN 61000-2-4	–	±10 %
Voltage deviations	EN 61000-2-4	–	≤ 3 %

Table 7: Electromagnetic compatibility

3.2 Dimensions and weights

3.2.1 Built-in version

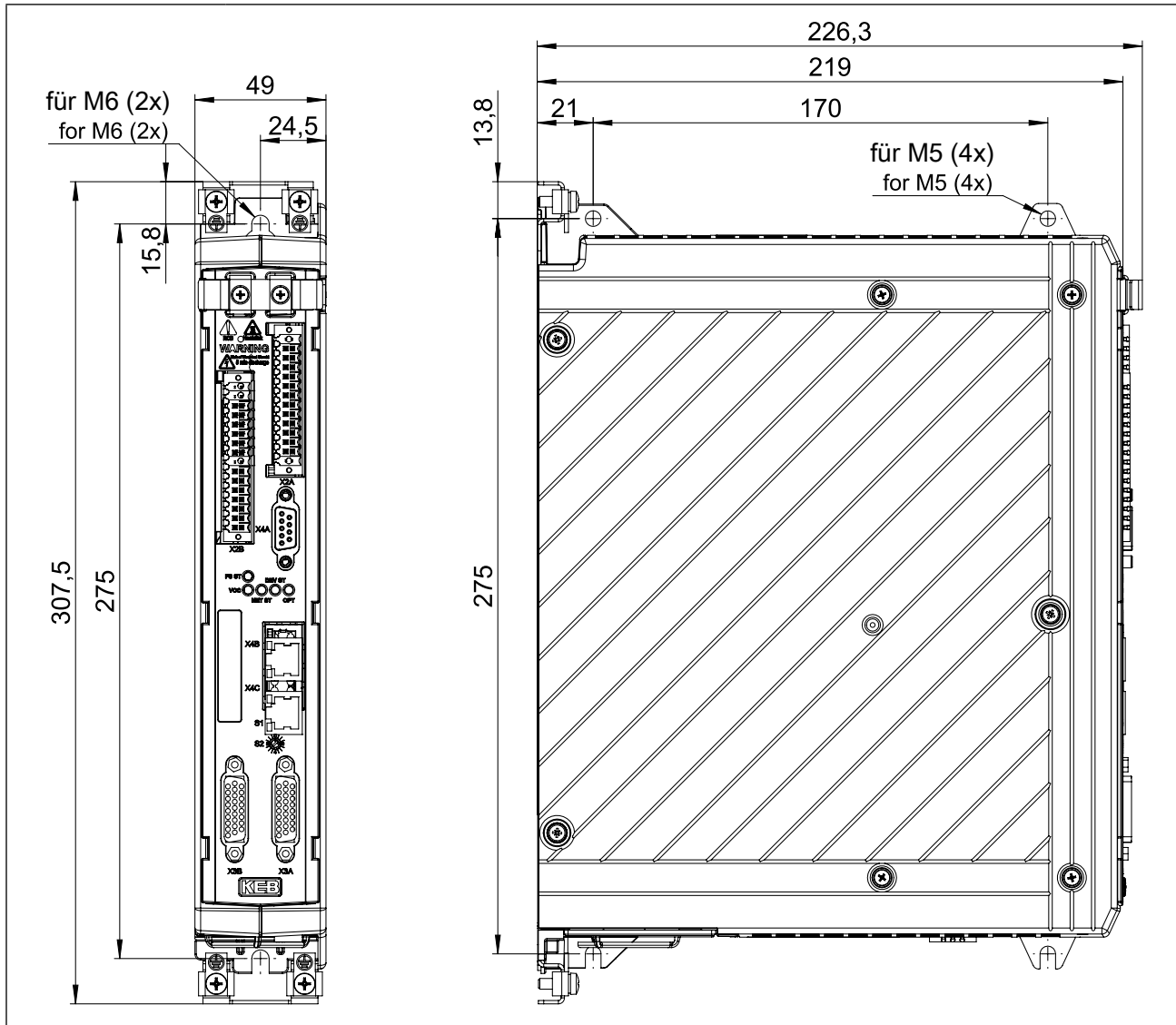

Housing	2
Weight	1.9 kg
Dimensions	All dimensions in mm

Figure 2: Dimensions built-in version housing 2

3.2.2 Built-in version with accessories

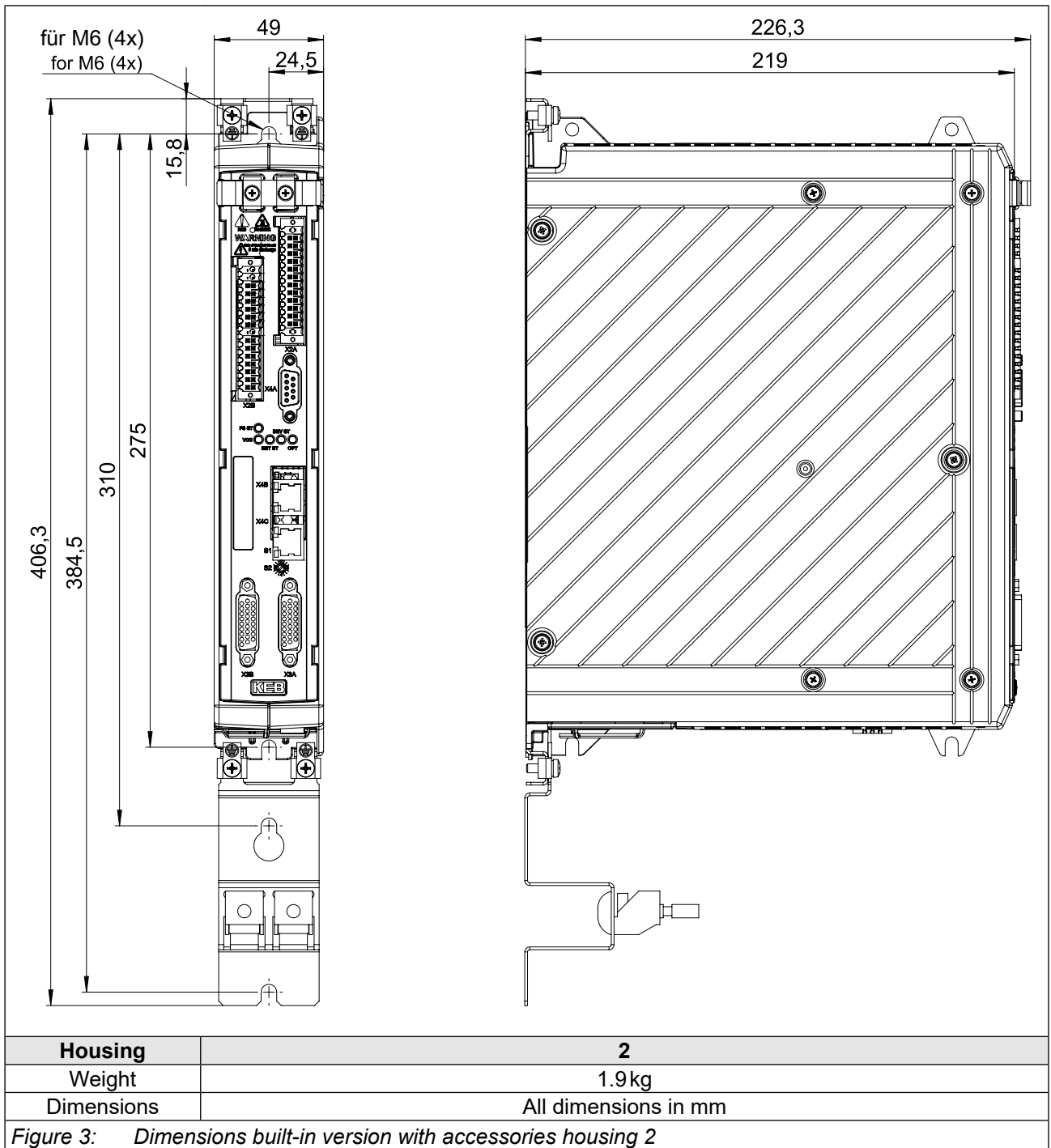

3.2.3 Control cabinet installation

Power dissipation for the control cabinet dimension => „3.4.6 Power loss during rated operation of 400 V devices“. A lower value can be used here depending on the operating mode/load.



Installation of the drive controller

For reliable operation, the drive controller must be installed without clearance on a smooth, closed, bare metal mounting plate.

Mounting distances	Dimension	Distance in mm	Distance in inch
	A	150	6
	B	100	4
	C	30	1,2
	D	0	0
	E	0	0
	F ¹⁾	50	2
	¹⁾ Distance to preceding elements in the control cabinet door.		

Figure 4: Mounting distances

If construction-conditioned the control cabinet cannot be without indoor ventilation, appropriate filters must avoid suction of foreign objects.

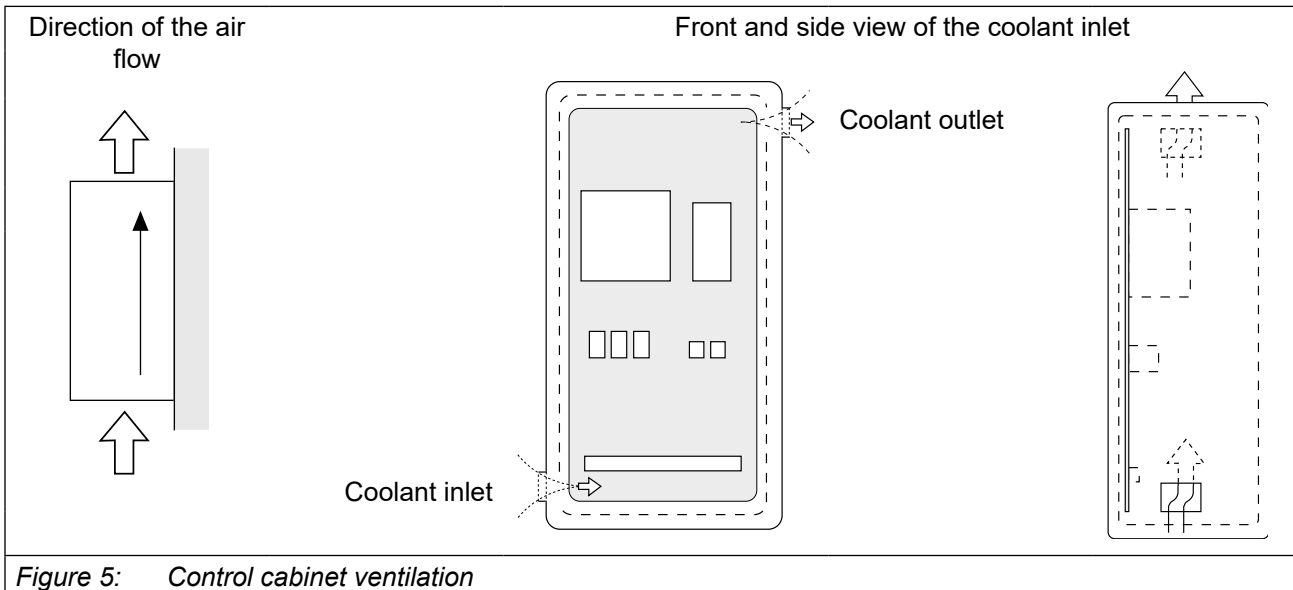

Figure 5: Control cabinet ventilation

3.3 Mounting instructions for control cabinet installation

For mounting the drive controllers, the following fastening materials with the corresponding quality were tested by KEB.

Required material	Tightening torque
Screw assembly ISO 7045 - M6 - 8.8	3.2 Nm 29 lb inch

Table 8: *Mounting instructions for control cabinet installation*

NOTICE

Use of other fastening material!

- ▶ The alternatively selected fastening material must comply with the above-mentioned material characteristics (quality) and tightening torques.
- ▶ The use of other fixing materials is beyond KEB's control and is therefore the sole responsibility of the customer.

3.3.1 Installation depth



For the various connections, it is recommended to keep the specified distance to upstream components.

The values given are approximate values. The actual installation depth must be checked individually by the user.

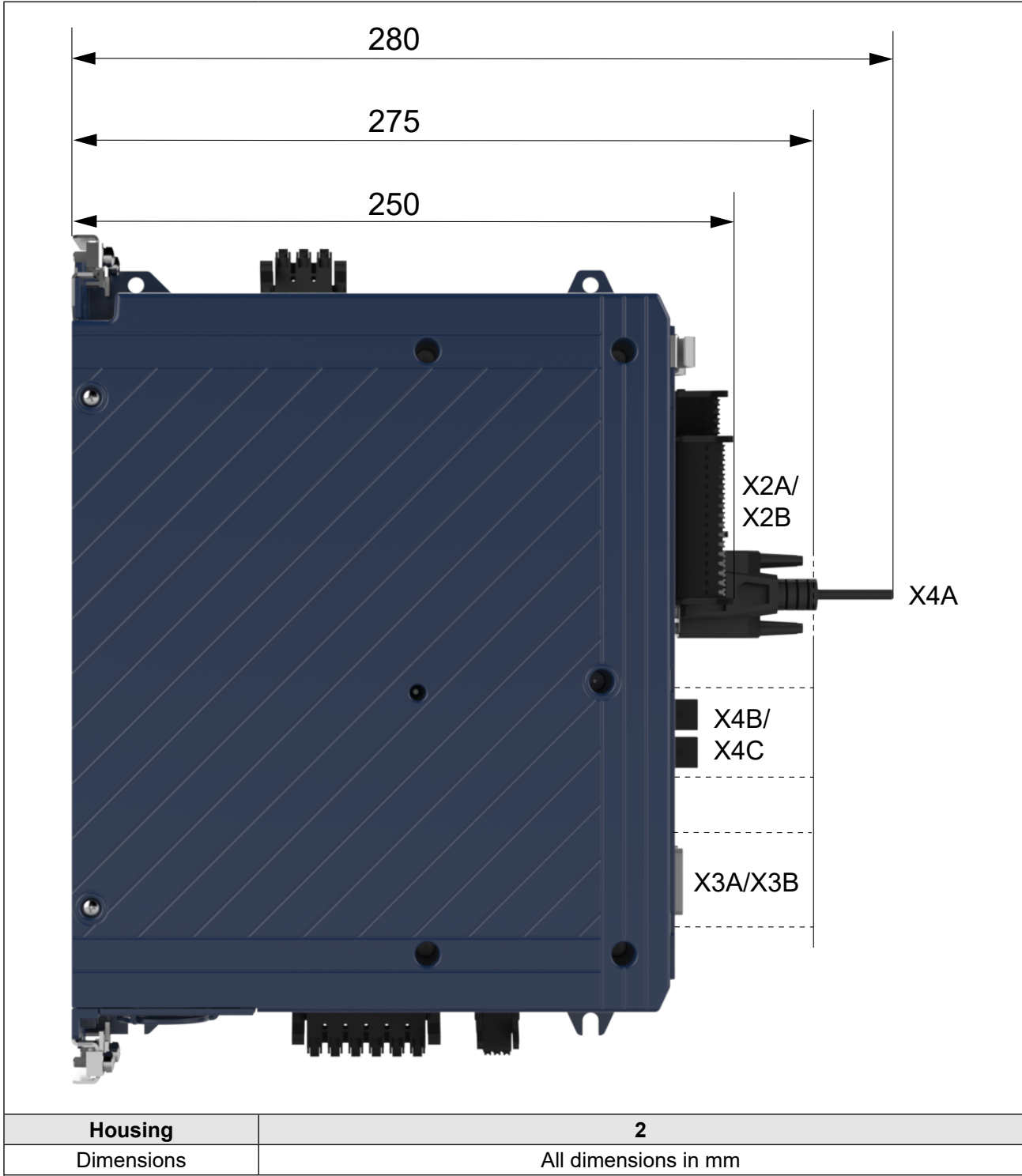

Figure 6: Installation depth

3.4 Device data of the 400 V devices

3.4.1 Overview of the 400V devices

The technical data are for 2/4-pole standard motors. With other pole numbers the drive controller must be dimensioned onto the rated motor current. Contact KEB for special or medium frequency motors.

Device size		07	09	10
Housing		2		
Rated apparent output power	S_{out} / kVA	1,8	2,8	4,0
Max. rated motor power	P_{mot} / kW	0,75	1,5	2,2
Rated output current	I_N / A	2,6	4,1	5,8
Output voltage	U_{out} / V	0... U_{in} or 0... $U_{in_dc} / \sqrt{2}$		
Output phases		3		
Output frequency	¹⁾ f_{out} / Hz	0...599		
Rated output overload (60 s)	²⁾ I_{60s} / %	200		
Rated output overload (3 s)	²⁾ I_{3s} / %	250		
Overcurrent	²⁾ I_{OC} / %	300		
Rated switching frequency	f_{SN} / kHz	8		
Rated input current	I_{in} / A	3,6	6,0	8,0
Rated input voltage	U_N / V	400		
Rated input voltage UL	U_{N_UL} / V	480		
Input voltage range	U_{in} / V	184...550		
Input voltage range DC supply	U_{in_dc} / V	260...750		
Mains phases		3		
Mains frequency	f_N / Hz	50/60		
Maximum current 0 Hz/50 Hz at $f_s = 4$ kHz	I_{out_max} / %	215/300	193/300	155/300
Maximum current 0 Hz/50 Hz at $f_s = 8$ kHz	I_{out_max} / %	162/300	132/300	103/275
Maximum current 0 Hz/50 Hz at $f_s = 16$ kHz	I_{out_max} / %	92/292	73/200	50/163
Insulation resistance @ $U_{dc} = 500$ V	R_{iso} / M Ω	> 15		
DC link capacity	C / μ F	195	195	235

Table 9: Overview device data of the 400 V devices

- ¹⁾ The output frequency is to be limited in such a way that it does not exceed 1/10 of the switching frequency. Devices with higher max. output frequency are subject to export restrictions and are only available upon request.
- ²⁾ The values refer in % to the rated output current I_N .

3.4.2 Rated operation

All rated values refer to a rated operation at $U_N = 400$ V, rated switching frequency f_{SN} and an output frequency $f_{out} = 50$ Hz.

3.4.3 Voltage and frequency specifications of the 400 V devices

Input voltage and frequencies		
Rated input voltage	U_N / V	400
Rated input voltage UL	U_{N_UL} / V	230 / 480
Input voltage range	U_{in} / V	184...550
Mains phases		3
Mains frequency	f_N / Hz	50/60
Mains frequency tolerance	$\pm f_N / \text{Hz}$	± 2

Table 10: Input voltages and frequencies of the 400 V devices

Input voltage for DC operation		
Rated input voltage DC	U_{N_dc} / V	565
Rated input voltage DC UL	$U_{N_dc_UL} / V$	680
Input voltage range DC supply	U_{in_dc} / V	260...750 ± 0

Table 11: Input voltages for DC operation of the 400 V devices

Output voltage and frequencies			
Output voltage at AC supply	¹⁾	U_{out} / V	$3 \times 0 \dots U_{in}$
Output voltage at DC supply	¹⁾	U_{out_dc} / V	$3 \times 0 \dots U_{in_dc} / \sqrt{2}$
Output frequency	²⁾	f_{out} / Hz	0...599

Table 12: Output voltages and frequencies of the 400 V devices

- ¹⁾ The voltage to the motor is dependent on the actual input voltage and the control method (=> „3.4.3.1 Example for the calculation of the motor voltage“).
- ²⁾ The output frequency is to be limited in such a way that it does not exceed 1/10 of the switching frequency. Devices with higher max. output frequency are subject to export restrictions and are only available upon request.

DC switching level		
DC switch-off level "Error! Underpotential"	U_{UP_dc} / V	200
DC switching level braking transistor	¹⁾ U_{B_dc} / V	780
DC switch-off level "Error! Overpotential"	U_{OP_dc} / V	840

Table 13: DC switching level 400 V devices

- ¹⁾ The DC switching level for the braking transistor is adjustable. The default value is the value specified in the table.

3.4.3.1 Example for the calculation of the motor voltage

The motor voltage for dimensioning of the drive is depending on the used components. The mains voltage reduces according to the following table:

Components	Reduction / %	Example:
Mains choke U_k	4	Closed-loop drive controller with mains and motor choke at non-rigid supply system: 400 V mains voltage - 15% = 340 V motor voltage
Drive controller open-loop	4	
Drive controller closed-loop	8	
Motor choke U_k	1	
Non-rigid supply system	2	

Table 14: Example for the calculation of the motor voltage

3.4.4 Input and output currents / overload of the 400 V devices

Input currents 400 V devices				
Device size		07	09	10
Rated input current @ $U_N = 400\text{V}$	I_{in} / A	3,6	6	8
Rated input current UL @ $U_{N_UL} = 480\text{V}$	I_{in_UL} / A	2,9	4,7	6,7
Rated input current DC @ $U_{N_dc} = 565\text{V}$	¹⁾ I_{in_dc} / A	4,4	7	10
Rated input current DC UL @ $U_{N_UL_dc} = 680\text{V}$	¹⁾ $I_{in_dc_UL} / \text{A}$	3,6	5,8	8

Table 15: Input currents of the 400 V devices

¹⁾ The values resulting from rated operation with B6 rectifier circuit and mains choke 4% U_k .

Output currents 400 V devices				
Device size		07	09	10
Rated output current @ $U_N = 400\text{V}$	I_N / A	2,6	4,1	5,8
Rated output current UL @ $U_{N_UL} = 480\text{V}$	I_{N_UL} / A	2,1	3,4	4,8
Overload current (60 s)	¹⁾ $I_{60s} / \%$	200		
Overload current (3 s)	¹⁾ $I_{3s} / \%$	250		
Overcurrent	¹⁾ $I_{OC} / \%$	300		

Table 16: Output currents of the 400 V devices

¹⁾ The values refer in % to the rated output current I_N .

3.4.5 Overview of rectifier data for 400 V devices

Device size		07	09	10
Rectifier rated power	P_{rect} / kW	1	1,9	2,7
Rectifier continuous power	¹⁾ $P_{rect_cont} / \text{kW}$	2,7	2,7	2,7
Continuous input current @ $U_N = 400\text{V}$	¹⁾ I_{in_cont} / A	8	8	8
Continuous input current @ $U_{N_UL} = 480\text{V} / 277\text{V}$	¹⁾ $I_{in_UL_cont} / \text{A}$	6,7	6,7	6,7
Rated output current DC @ $U_{N_dc} = 565\text{V}$	I_{out_dc} / A	4,4	7	10
Continuous output current DC @ $U_{N_dc} = 565\text{V}$	¹⁾ $I_{out_dc_cont} / \text{A}$	10	10	10
Rated output current DC @ $U_{N_UL_dc} = 680\text{V}$	$I_{out_UL_dc} / \text{A}$	3,6	5,8	8
Continuous output current DC @ $U_{N_UL_dc} = 680\text{V}$	¹⁾ $I_{out_UL_dc_cont} / \text{A}$	8	8	8

Table 17: Overview of rectifier data for 400 V devices

¹⁾ Continuous operation is a load beyond the rated operation. Continuous operation only occurs when the internal rectifier is used to supply additional drive converters via the DC terminals => „4.2.6 DC-bus connection“. In continuous operation, the OH error may be triggered depending on the operating conditions of the internal inverter.

3.4.6 Power loss during rated operation of 400 V devices

Device size		07	09	10
Rated switching frequency	f_{SN} / kHz	8	8	8
Power dissipation at rated operation	¹⁾ P_D / W	65	90	115
Power dissipation at rated operation	²⁾ P_{D_dc} / W	65	85	105

Table 18: Power loss of 400 V devices

¹⁾ Rated operation corresponds to $U_N = 400\text{ V}$; f_{SN} ; I_N ; $f_N = 50\text{ Hz}$ (typically value).

²⁾ Rated operation DC corresponds to $U_{N_dc} = 565\text{ V}$; I_N .

3.5 Device data of the 230 V devices

3.5.1 Overview of the 230V devices

The technical data are for 2/4-pole standard motors. With other pole numbers the drive controller must be dimensioned onto the rated motor current. Contact KEB for special or medium frequency motors.

Device size		07	09
Housing		2	
Rated apparent output power	S_{out} / kVA	1,6	2,8
Max. rated motor power	P_{mot} / kW	0,75	1,5
Rated output current	I_N / A	4	7
Output voltage	U_{out} / V	0... U_{in}	
Output phases		3	
Output frequency	¹⁾ f_{out} / Hz	0...599	
Rated output overload (60s)	²⁾ I_{60s} / %	150	
Rated output overload (3s)	²⁾ I_{3s} / %	200	
Overcurrent	²⁾ I_{oc} / %	240	
Rated switching frequency	f_{SN} / kHz	8	
Rated input current	I_{in} / A	8	14
Rated input voltage	U_N / V	230	
Input voltage range	U_{in} / V	184...265	
Input voltage range DC supply	U_{in_dc} / V	260...375	
Mains phases		1	
Mains frequency	f_N / Hz	50/60	
Maximum current 0 Hz/50 Hz at $f_s=4$ kHz	I_{out_max} / %	175/240	157/240
Maximum current 0 Hz/50 Hz at $f_s=8$ kHz	I_{out_max} / %	150/240	114/240
Maximum current 0 Hz/50 Hz at $f_s=16$ kHz	I_{out_max} / %	100/240	85/240
Insulation resistance @ $U_{dc} = 500$ V	R_{iso} / M Ω	> 5	
DC link capacity	C / μ F	1170	1410

Table 19: Overview device data of the 230 V devices

¹⁾ The output frequency is to be limited in such a way that it does not exceed 1/10 of the switching frequency. Devices with higher max. output frequency are subject to export restrictions and are only available upon request.

²⁾ The values refer in % to the rated output current I_N .

3.5.2 Rated operation

All rated values refer to a rated operation at $U_N = 230$ V, rated switching frequency f_{SN} and an output frequency $f_{out} = 50$ Hz.

3.5.3 Voltage and frequency specifications of the 230 V devices

Input voltage and frequencies		
Rated input voltage	U_N / V	230
Rated input voltage UL	U_{N_UL} / V	120...230
Input voltage range	U_{in} / V	184...265
Mains phases		1
Mains frequency	f_N / Hz	50/60
Mains frequency tolerance	$\pm f_N / \text{Hz}$	± 2
Table 20: Input voltages and frequencies of the 230 V devices		

Output voltage and frequencies		
Output voltage at AC supply	¹⁾ U_{out} / V	$3 \times 0 \dots U_{in}$
Output frequency	²⁾ f_{out} / Hz	0...599
Table 21: Output voltages and frequencies of the 230 V devices		

- ¹⁾ The voltage to the motor is dependent on the actual input voltage and the control method (=> „3.4.3.1 Example for the calculation of the motor voltage“).
- ²⁾ The output frequency is to be limited in such a way that it does not exceed 1/10 of the switching frequency. Devices with higher max. output frequency are subject to export restrictions and are only available upon request.

DC switching level		
DC switch-off level "Error! Underpotential"	U_{UP_dc} / V	200
DC switching level braking transistor	¹⁾ U_{B_dc} / V	380
DC switch-off level "Error! Overpotential"	U_{OP_dc} / V	420
Table 22: DC switching level of the 230 V devices		

- ¹⁾ The DC switching level for the braking transistor is adjustable. The default value is the value specified in the table.

3.5.4 Input and output currents / overload of the 230 V devices

Input currents 230 V devices			
Device size		07	09
Rated input current @ $U_N = 230\text{ V}$	I_{in} / A	8	14
Rated input current UL @ $U_{N_UL} = 230\text{ V}$	I_{in_UL} / A	8	14

Table 23: Input currents of the 230 V devices

¹⁾ The values resulting from rated operation with B6 rectifier circuit and mains choke 4% U_k .

Output currents 230 V devices			
Device size		07	09
Rated output current @ $U_N = 230\text{ V}$	I_N / A	4	7
Rated output current UL @ $U_{N_UL} = 230\text{ V}$	I_{N_UL} / A	4	7
Rated output overload (60 s)	¹⁾ $I_{60s} / \%$	150	
Rated output overload (3 s)	¹⁾ $I_{3s} / \%$	200	
Overcurrent	¹⁾ $I_{OC} / \%$	240	

Table 24: Output currents of the 230 V devices

¹⁾ The values refer in % to the rated output current I_N .

3.5.5 Power loss during rated operation of 230 V devices

Device size		07	09
Power dissipation at rated operation	¹⁾ P_D / W	60	95
Power dissipation at DC supply	¹⁾ P_{D_dc} / W	70	50

Table 25: Power dissipation 230 V devices

¹⁾ Rated operation corresponds to $U_N = 400\text{ V}$; f_{SN} ; $f_{out} = 50\text{ Hz}$ (typically value).

3.6 General data

3.6.1 Overload characteristic (OL)

The OL overload function is a root mean square (RMS) function. The greater the jumps between the overload and underload phases, the greater the deviation of the RMS from the arithmetic mean. For extreme overloads (=> „*Figure 7: Switch-off time t depending on the overload I/I_N (OL) 400 V devices*“ and „*Figure 8: Switch-off time t depending on the overload I/I_N (OL) 230 V devices*“) the load is weighted more heavily. This means the RMS value is calculated with a factor of the overload, so that the overload protection function triggers even if the RMS value does not reach 100%.

Restrictions:

- The thermal design of the heat sink is based on the rated current and the maximum permissible ambient temperature. At high ambient temperatures and/or high heat sink temperatures (for example, by preceding utilisation nearby 100%), the drive controller can change to overtemperature error before triggering the protective function OL.
- At low output frequencies or switching frequencies higher than the rated switching frequency, the maximum current (10Hz/16Hz) can be exceeded before and the error OL2 can be triggered (see also chapter "Maximum current (OL2)").

On exceeding a load of 105% the overload integrator starts. When falling below the integrator counts backwards. If the integrator achieves the overload characteristic, "Error! Overload" is triggered.

After a cooling period the message "no ERROR overload" is displayed. The error can be reset now. The drive controller must remain switched on during the cooling down phase.

3.6.1.1 Switch-off time depending on the overload at 400V devices

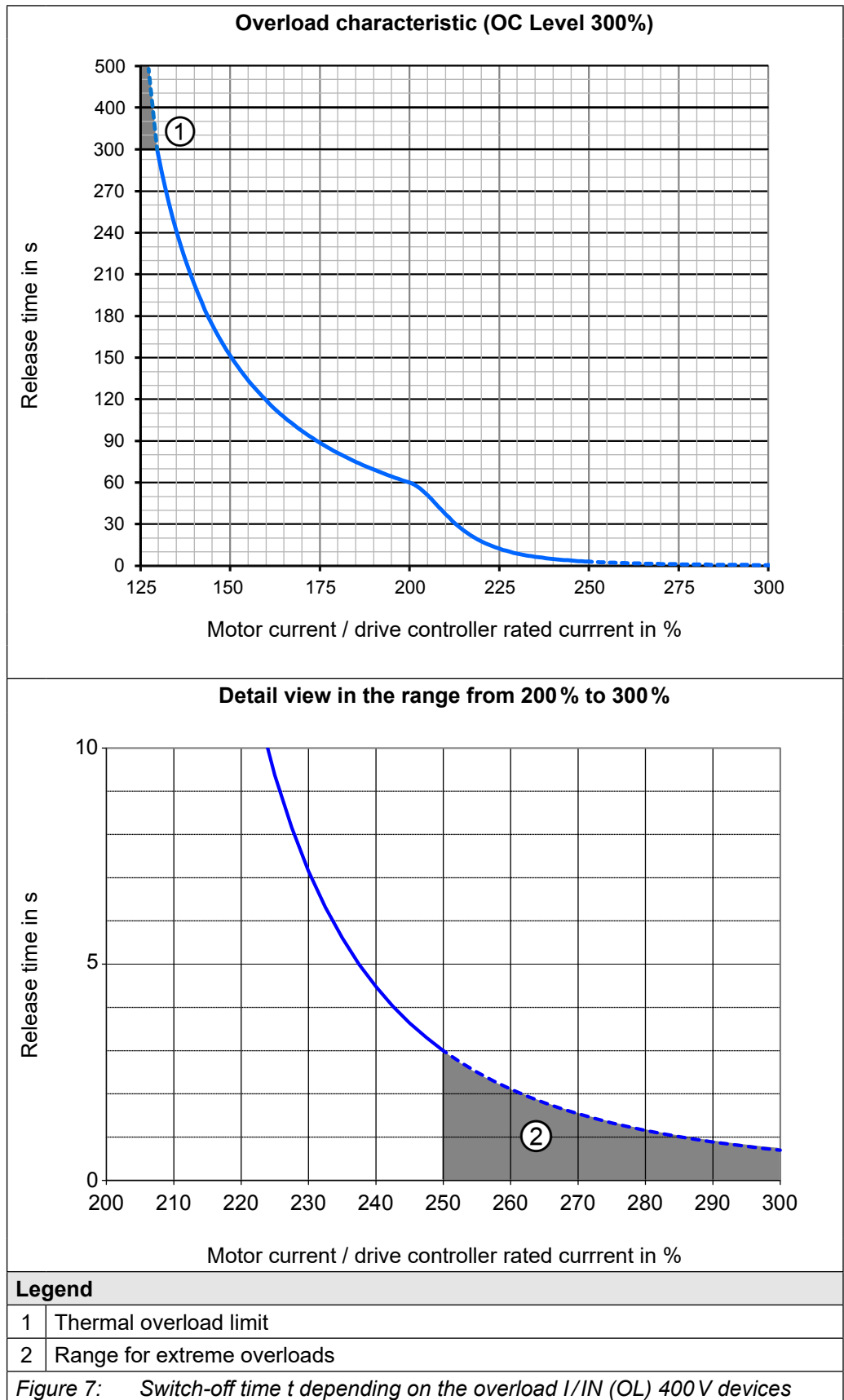

3.6.1.2 Switch-off time depending on the overload at 230 V devices

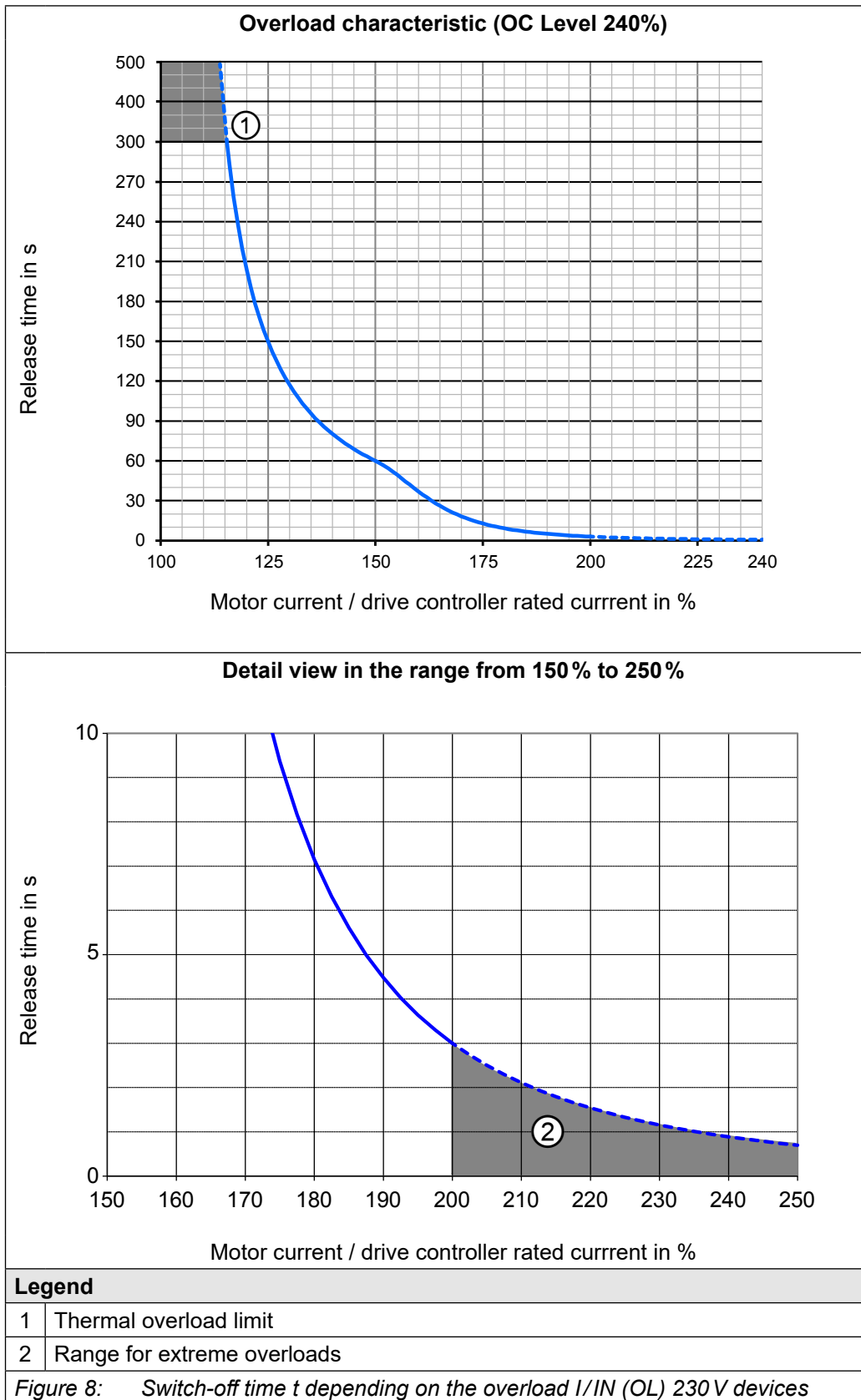

3.6.1.3 Maximum current (OL2)

It can be adjusted in the drive controller parameters if error (OL2) shall be triggered when exceeding the maximum currents, or if the switching frequency is automatically reduced (derating).

The following tables indicate the permissible maximum current for 6 output frequency values. In between there is a linear interpolation. Device size 07 is represented exemplary.



The characteristic curves represent the real maximum current values using the example of device size 07 (400V).

Legend

	Overcurrent I_{oc}
	Switching frequency 4 kHz
	Switching frequency 8 kHz
	Switching frequency 16 kHz
	Not available for modulation. The error OC is triggered at 300 % overload.

Figure 9: Overload characteristic in the lower speed range (OL2)



The frequency-dependent maximum current I_{out_max} refers in % to the rated output current I_N .

From the last specified output frequency value, the current remains constant.



The values for the respective device size are listed in the following tables.

Frequency-dependent maximum current 400 V devices

Device size		07					
Rated switching frequency		8 kHz					
Output frequency	f_{out} / Hz	0	3,1	6,2	12,5	25	50
Frequency-dependent maximum current @ f_s Basic Time Period = 62.5 μ s (Parameter is22=0)	i_{out_max} / %						
		4 kHz	215	300	300	300	300
		8 kHz	162	238	292	300	300
		16 kHz	92	158	200	235	265
Frequency-dependent maximum current @ f_s Basic Time Period = 71.4 μ s (Parameter is22=1)	i_{out_max} / %	7 kHz	175	254	300	300	300
		14 kHz	104	175	215	252	287
Frequency-dependent maximum current @ f_s Basic Time Period = 83.3 μ s (Parameter is22=2)	i_{out_max} / %	6 kHz	188	269	300	300	300
		12 kHz	115	192	231	269	308
Frequency-dependent maximum current @ f_s Basic Time Period = 100 μ s (Parameter is22=3)	i_{out_max} / %	5 kHz	202	285	300	300	300
		10 kHz	138	215	262	300	300

Table 26: Frequency-dependent maximum current for device size 07 400 V devices

Device size		09					
Rated switching frequency		8 kHz					
Output frequency	f_{out} / Hz	0	3,1	6,2	12,5	25	50
Frequency-dependent maximum current @ f_s Basic Time Period = 62.5 μ s (Parameter is22=0)	i_{out_max} / %						
		4 kHz	193	266	300	300	300
		8 kHz	132	198	234	256	283
		16 kHz	73	122	146	166	183
Frequency-dependent maximum current @ f_s Basic Time Period = 71.4 μ s (Parameter is22=1)	i_{out_max} / %	7 kHz	147	215	253	276	300
		14 kHz	85	138	159	180	201
Frequency-dependent maximum current @ f_s Basic Time Period = 83.3 μ s (Parameter is22=2)	i_{out_max} / %	6 kHz	162	232	272	296	300
		12 kHz	98	154	171	195	220
Frequency-dependent maximum current @ f_s Basic Time Period = 100 μ s (Parameter is22=3)	i_{out_max} / %	5 kHz	177	249	291	300	300
		10 kHz	115	176	202	226	251

Table 27: Frequency-dependent maximum current for device size 09 400 V devices

Device size		10					
Rated switching frequency		8 kHz					
Output frequency	f_{out} / Hz	0	3,1	6,2	12,5	25	50
Frequency-dependent maximum current @ f_s Basic Time Period = 62.5 μ s (Parameter is22=0)	i_{out_max} / %						
		4 kHz	155	250	284	300	300
		8 kHz	103	172	207	233	255
		16 kHz	50	103	121	138	155
Frequency-dependent maximum current @ f_s Basic Time Period = 71.4 μ s (Parameter is22=1)	i_{out_max} / %	7 kHz	116	192	226	254	278
		14 kHz	64	116	138	155	177
Frequency-dependent maximum current @ f_s Basic Time Period = 83.3 μ s (Parameter is22=2)	i_{out_max} / %	6 kHz	129	211	246	276	300
		12 kHz	78	129	155	172	198
Frequency-dependent maximum current @ f_s Basic Time Period = 100 μ s (Parameter is22=3)	i_{out_max} / %	5 kHz	142	231	265	297	300
		10 kHz	91	151	181	203	227

Table 28: Frequency-dependent maximum current for device size 10 400 V devices

Frequency-dependent maximum current 230 V devices

Device size		07					
Rated switching frequency		8 kHz					
Output frequency	f_{out} / Hz	0	3,1	6,2	12,5	25	50
Frequency-dependent maximum current @ f_s Basic Time Period = 62.5 μ s (Parameter is22=0)	4 kHz	175	240	240	240	240	240
	i_{out_max} / %	150	200	240	240	240	240
	8 kHz	150	200	240	240	240	240
Frequency-dependent maximum current @ f_s Basic Time Period = 71.4 μ s (Parameter is22=1)	16 kHz	100	150	200	240	240	240
	i_{out_max} / %	156	213	240	240	240	240
	7 kHz	156	213	240	240	240	240
Frequency-dependent maximum current @ f_s Basic Time Period = 83.3 μ s (Parameter is22=2)	14 kHz	113	163	213	240	240	240
	i_{out_max} / %	163	225	240	240	240	240
	6 kHz	163	225	240	240	240	240
Frequency-dependent maximum current @ f_s Basic Time Period = 100 μ s (Parameter is22=3)	12 kHz	125	175	225	240	240	240
	i_{out_max} / %	169	238	240	240	240	240
	5 kHz	169	238	240	240	240	240
		10 kHz	138	188	238	240	240

Table 29: Frequency-dependent maximum current for device size 07 230 V devices

Device size		09					
Rated switching frequency		8 kHz					
Output frequency	f_{out} / Hz	0	3,1	6,2	12,5	25	50
Frequency-dependent maximum current @ f_s Basic Time Period = 62.5 μ s (Parameter is22=0)	4 kHz	157	214	240	240	240	240
	i_{out_max} / %	114	171	229	240	240	240
	8 kHz	114	171	229	240	240	240
Frequency-dependent maximum current @ f_s Basic Time Period = 71.4 μ s (Parameter is22=1)	16 kHz	86	143	200	229	240	240
	i_{out_max} / %	125	182	234	240	240	240
	7 kHz	125	182	234	240	240	240
Frequency-dependent maximum current @ f_s Basic Time Period = 83.3 μ s (Parameter is22=2)	14 kHz	93	150	207	232	240	240
	i_{out_max} / %	136	193	239	240	240	240
	6 kHz	136	193	239	240	240	240
Frequency-dependent maximum current @ f_s Basic Time Period = 100 μ s (Parameter is22=3)	12 kHz	100	157	214	236	240	240
	i_{out_max} / %	146	204	240	240	240	240
	5 kHz	146	204	240	240	240	240
		10 kHz	107	164	221	240	240

Table 30: Frequency-dependent maximum current for device size 09 230 V devices

3.6.2 Switching frequency and temperature

The drive controller cooling is designed by way that the heat sink overtemperature threshold is not exceeded at rated conditions. A switching frequency higher than the rated switching frequency also produces higher losses and thus a higher heat sink heating. If the heat sink temperature reaches a critical threshold (T_{dr}) the switching frequency can be reduced automatically step by step, in order to prevent that the drive controller switches off due to overheating of the heat sink. If the heat sink temperature falls below T_{ur} , the switching frequency is increased to the setpoint again. At temperature T_{em} the switching frequency is immediately reduced to rated switching frequency. "Derating" must be activated, for this function to work.

Voltage class	400 V			230 V	
	07	09	10	07	09
Device size					
Mains phases	3			1	
Rated switching frequency ¹⁾ f_{SN} / kHz	8			8	
Max. switching frequency ¹⁾ f_{S_max} / kHz	16			16	
Max. heat sink temperature T_{HS} / °C	90			80	
Temperature for derating the switching frequency ²⁾ T_{dr} / °C	80			70	
Temperature for uprating the switching frequency ²⁾ T_{ur} / °C	70			60	
Temperature for switching to rated switching frequency ²⁾ T_{em} / °C	85			75	

Table 31: Switching frequency and temperature

¹⁾ The output frequency is to be limited in such a way that it does not exceed 1/10 of the switching frequency.
²⁾ On reaching the temperature T_{dr} the switching frequency is step down. The switching frequency is increased again on cooling down to temperature T_{ur} .
 If derating is not requested in individual cases, the function can be deactivated via software.

3.6.3 Fusing of the drive controllers

3.6.3.1 Protection of 400 V devices with AC supply, 3-phase

At 400V operation, 3-phase			
Device size	Fuse in A		Alternatively Motor protection switch
	$U_N = 400\text{ V}$ gG (IEC)	$U_N = 480\text{ V}$ Class "CC" or "J" (UL)	Eaton PKZM0 10-E (IEC/UL)
	SCCR 30 kA	SCCR 30 kA	SCCR 30 kA
07	6	6	480Y/277V, 7.5HP
09	10	10	
10	10	10	
At 230V operation, 3-phase			
Device size	Fuse in A		Alternatively Motor protection switch
	$U_N = 230\text{ V}$ gG (IEC)	$U_N = 200\text{-}230\text{ V}$ class „CC“ (UL)	Eaton PKZM0 10-E (IEC/UL)
	SCCR 30 kA	SCCR 30 kA	SCCR 30 kA
07	6	6	200-230V, 3HP
09	10	10	
10	10	10	

Table 32: Fuse protection of drive converters 400 V devices, 3-phase AC

3.6.3.2 Fuse protection of 230 V devices with AC supply, 1-phase

Device size	Fuse in A			Alternatively Motor protection switch
	$U_N = 230\text{ V}$ gG (IEC)	$U_N = 120\text{-}230\text{ V}$ class "CC" ¹⁾	$U_N = 120\text{-}230\text{ V}$ class "CC" or "J" (UL)	Eaton PKZM0 20-E (IEC/UL)
	SCCR 30 kA	SCCR 30 kA	SCCR 5 kA	SCCR 5 kA
07	15	15	15	115V/1ph, 1.5 hp
09	20	20	20	230V/1ph, 3 hp

Table 33: Fuse protection of drive converters 230 V devices, 1-phase AC

¹⁾ For mains with an unaffected symmetrical short-circuit current of max. 5kA eff. additional fuses of the class J are permissible.



Short-circuit capacity

According to requirements from [EN 60439-1](#) and [EN 61800-5-1](#), the following applies to connection to a mains supply: The devices are suitable for use in a circuit capable of delivering not more than 30 kA eff. unaffected symmetrical short-circuit current.

3.6.3.3 Protection of 400 V devices with DC supply

Device size	Recommended fuse size / A		Permissible fuses ¹⁾
	$U_{N_dc} = 565V$	$U_{N_UL_dc} = 680V$	
	SCCR 30 kA	SCCR 30 kA	
07	16	16	SIBA 50 215 06.20 SIBA 50 204 34.25 SIBA 50 118 06.30
09	16	16	SIBA 50 120 06.32 SIBA 20 209 37.50 ²⁾ SIBA 50 268 06.50
10	16	16	SIBA 50 201 06.50 SIBA 50 250 06.50 Bussmann FWP-50A14F Bussmann 170M1414 Littelfuse L70QS050

Table 34: Protection of drive converters with DC supply

¹⁾ Fuses of the same type with lower rated currents can be used if they are suitable for the application.

²⁾ Fuse without UL certification.

NOTICE

Observe the rated voltage of the fuse!

- The rated voltage of the fuse must be at least equal to the maximum DC supply voltage of the drive converter.

3.6.3.4 Motor-protective circuit-breakers / circuit-breakers

This chapter lists the recommended and alternative motor protection switches/circuit breakers for protecting the drive controller. The selection of the recommended protection switches is based on continuous operation (S1 operation) at 100% load and maximum ambient temperature. If operating conditions differ, the circuit breakers must be dimensioned accordingly (see manufacturer's documentation for the respective circuit breakers).

Device size	Recommended motor-protective circuit-breakers / circuit-breakers						
	IEC ($U_N = 400V$)			UL ($U_{N_UL} = 480V$)			
	Type	Rated current / A	SCCR @ U_N / kA	Type	Rated current / A	Rated power / hp	SCCR @ U_{N_UL} / kA
07	Eaton PKZM0-6.3	6,3	30	Eaton PKZM0-6.3	6,3	3	30
09	Eaton PKZM0-6.3	6,3	30	Eaton PKZM0-6.3	6,3	3	30
10	Eaton PKZM0-10	10	30	Eaton PKZM0-10	10	7,5	30

Table 35: Recommended motor protective circuit-breakers / circuit breakers for 400 V / 480 V appliances

As an alternative to the recommended motor protection switches/circuit breakers, all circuit breakers listed in the following table may be used. Circuit breakers of the same type with a lower rated current or other features (e.g., connection terminals, actuation types, etc.) may also be used, provided that they are suitable for the application and the differing features do not have a negative effect on the pass values (I^2t and I_p). Circuit breakers of the same type with lower breaking capacity may be used provided they are suitable for the application. In this case, the short-circuit current rating (SCCR) of the combination of drive controller and circuit breaker is reduced to the breaking capacity of the circuit breaker.

Some motor circuit breakers require additional accessories in order to be used as Type E Combination Motor Controllers in UL-certified installations (see manufacturer's documentation for the respective circuit breaker).

Alternative motor-protective circuit-breaker / circuit-breaker			
Type	Rated current / A	Rated power / hp	SCCR / kA
Eaton PKZM0-10	10	7,5	30
Siemens 3RV2011-1JA10	10	10	30
Siemens 3RV2021-1JA10	10	20	30
Schneider GV2P14	10	5	10
Siemens 5SJ4310-7HG42	10	—	30

Table 36: Alternative motor protective circuit-breakers / circuit breaker for 400 V / 480 V appliances



IEC only:

Motor-protective circuit-breakers / circuit-breakers not listed here can be used provided they fulfil the following requirements:

- Passing integral $I^2t @ U_N < 32 \text{ kA}^2\text{s}$
- Throughput current $I_p @ U_N < 6,6 \text{ kA}$

3.6.4 DC link / braking transistor function

3.6.4.1 DC link / braking transistor function of the 400 V devices

Device size		07	09	10
DC link rated voltage @ $U_N = 400\text{V}$	U_{N_dc} / V	565		
DC link rated voltage @ $U_N = 480\text{V}$	$U_{N_dc_UL} / \text{V}$	680		
DC link voltage working voltage range	U_{in_dc} / V	260...750 \pm 0		
DC switching level braking transistor	¹⁾ U_B / V	780		
Max. braking current	I_{B_max} / A	5,5	8	11
Min. braking resistor value	R_{B_min} / Ω	160	110	82
Protective function for braking transistor	²⁾	—		
Min. internal precharge resistance	R_{pc_int} / Ω	58		
Max. precharge current	I_{pc_max} / A	63		

Table 37: DC link / braking transistor function of the 400 V devices

¹⁾ The DC switching level for the braking transistor is adjustable. The default value is the value specified in the table.

²⁾ No protective function, => „4.2.8.2 Use of intrinsically safe braking resistors“.

3.6.4.2 DC link / braking transistor function of the 230V devices

Device size		07	09
DC switch-off level "Error! Underpotential"	U_{UP} / V	200	
DC switch-off level "Error! Overpotential"	U_{OP} / V	420	
DC switching level braking transistor	¹⁾ U_B / V	380	
Max. braking current	I_{B_max} / A	7,5	12,7
Min. braking resistor value	R_{B_min} / Ω	56	33
Protective function for braking transistor	²⁾	—	

Table 38: DC link / braking transistor function of the 230 V devices

¹⁾ The DC switching level for the braking transistor is adjustable. The default value is the value specified in the table.

²⁾ No protective function, => „4.2.8.2 Use of intrinsically safe braking resistors“.

NOTICE

DC-bus connection

- The use of a 230V DC network is only permitted after consultation with KEB!

3.6.5 DC link / braking transistor function

NOTICE

Falling below the minimum braking resistor value !

Destruction of the drive controller

► The minimum brake resistance value must not fall below!

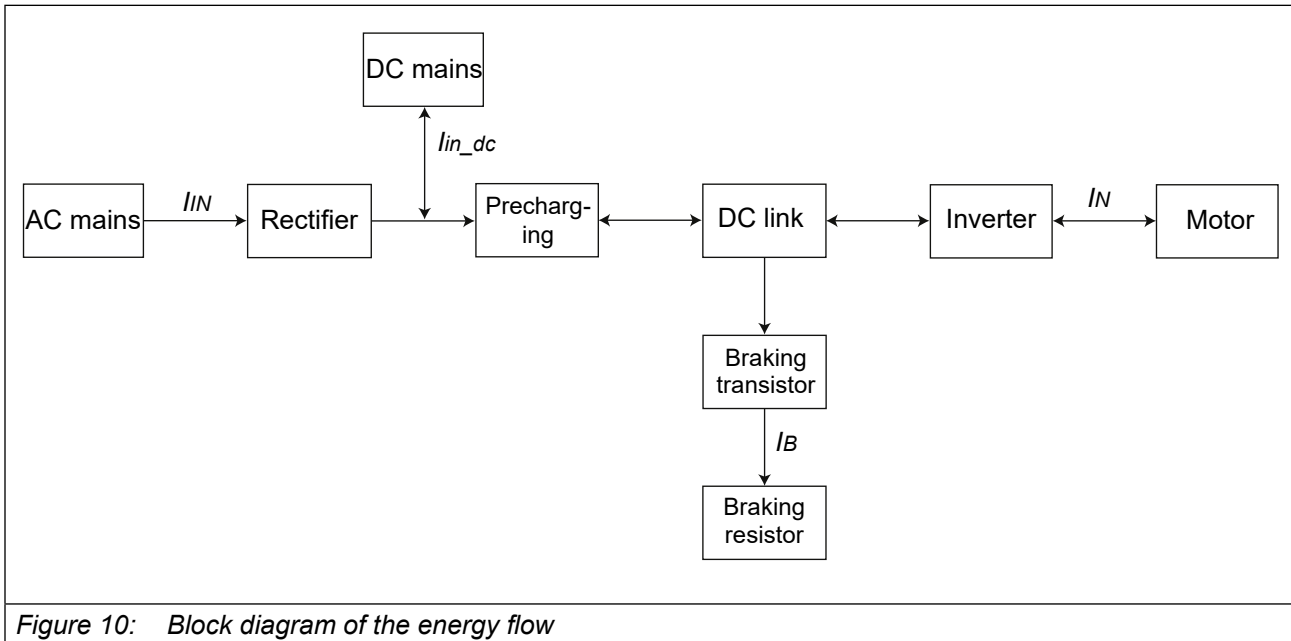

Activation of the braking transistor function

The function must be activated with parameter "is30 braking transistor function" in order to use the braking transistor.

Further informations are available in the download area at www.keb-automation.com with the search term „S6 Programming manual“.

3.6.6 Fan

Device size		07	09	10
Heat sink fan	Number		1	
	Speed-variable		—	

NOTICE

Destruction of the fan!

► Take care that no foreign substances drop into the fan.

3.6.6.1 Switching behaviour of the fan

The fan has different switch-on and switch-off points. The switching point for the switch-on temperature ① of the fan is adjustable. The switching point for the switch-off temperature ② cannot be changed and is always 5°C below the switch-on temperature.

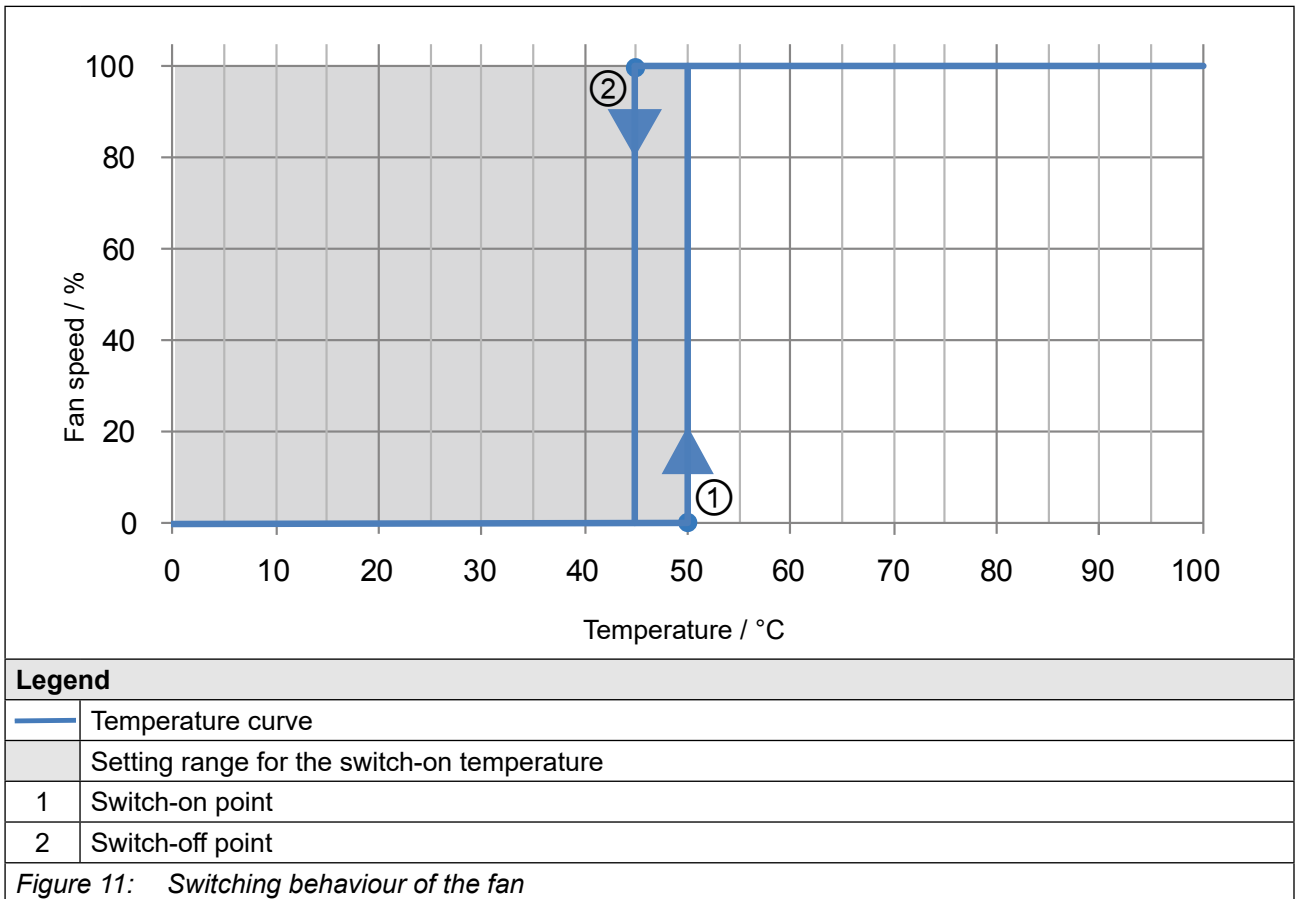

3.6.6.2 Switching points of the fan

The switching point for the switch-on temperature is adjustable between 0.1 °C and 50 °C. The default value is 50 °C.

4 Installation and connection

4.1 Overview of the COMBIVERT S6

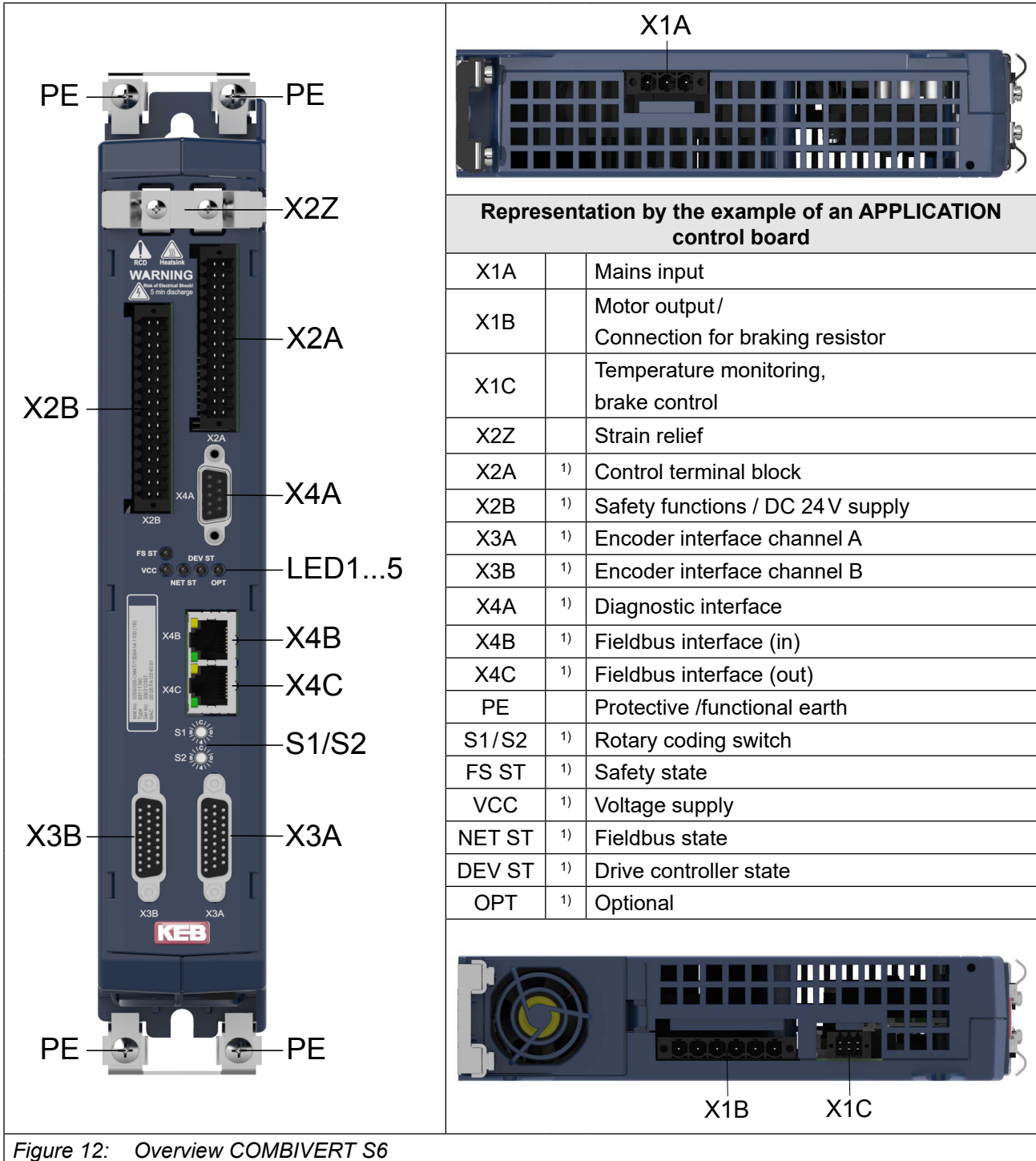

Figure 12: Overview COMBIVERT S6

1) Is described in the installation manual of the control board.



Instructions for use COMBIVERT S6 control board
APPLICATION

www.keb.de/fileadmin/media/Manuals/dr/ma_dr_s6-cu-a-inst-20109645_en.pdf



Instructions for use COMBIVERT S6 control board
COMPACT

www.keb.de/fileadmin/media/Manuals/dr/ma_dr_s6-cu-k-inst-20087885_en.pdf



Instructions for use COMBIVERT S6 control board
PRO

www.keb.de/fileadmin/media/Manuals/dr/ma_dr_s6-cu-p-inst-20156056_en.pdf



4.2 Connection of the power unit

4.2.1 Connection of the voltage supply

The COMBIVERT S6 corresponds to the drive controller type A1. This type can be supplied both by mains and via DC terminals. The starting current limiting is arranged before the DC link. When using as DC output, parallel connected drive controllers must have their own starting current limiting at the DC voltage input.

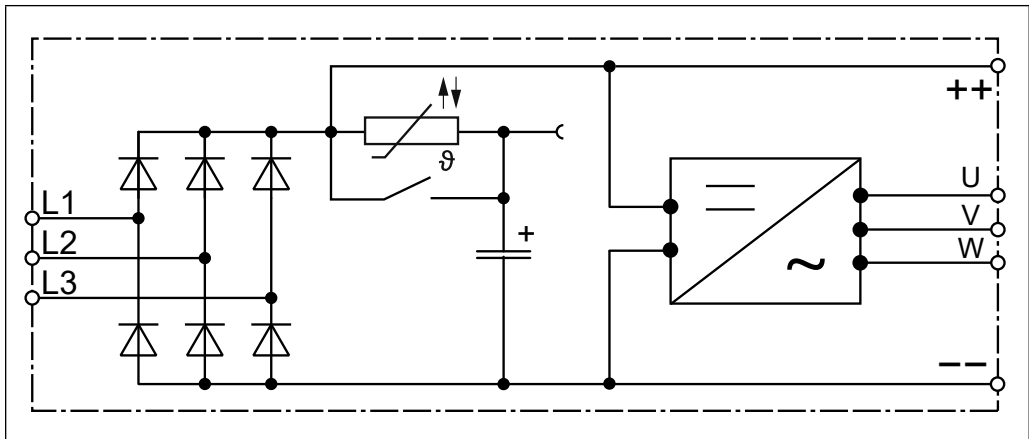

Figure 13: Input wiring / drive controller type

4.2.1.1 230V devices

The COMBIVERT S6 can be supplied both by mains and via DC terminals. The starting current limiting is arranged before the DC link. When using as DC output, parallel connected drive controllers must have their own starting current limiting at the DC voltage input.

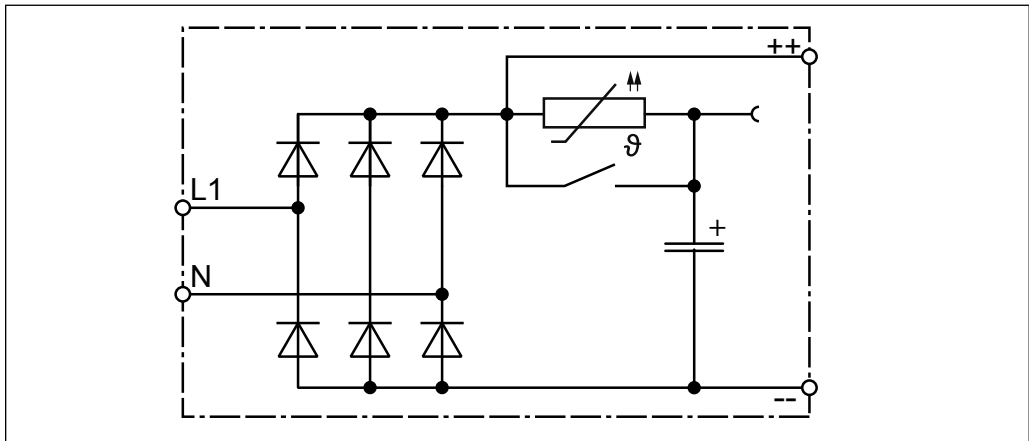

Figure 14: Input circuit/drive controller type 230V devices

NOTICE



Minimum waiting time between two switch-on procedures 5 minutes!

- ▶ Cyclic switching on and off of the unit leads to temporary high resistance of the resistor (PTC) in the input.
- ▶ A restart without limitation is possible after cooling.

NOTICE

Destruction of the drive controller!

- ▶ Never exchange connections mains input and motor output.

4.2.1.2 Mains terminal block X1A

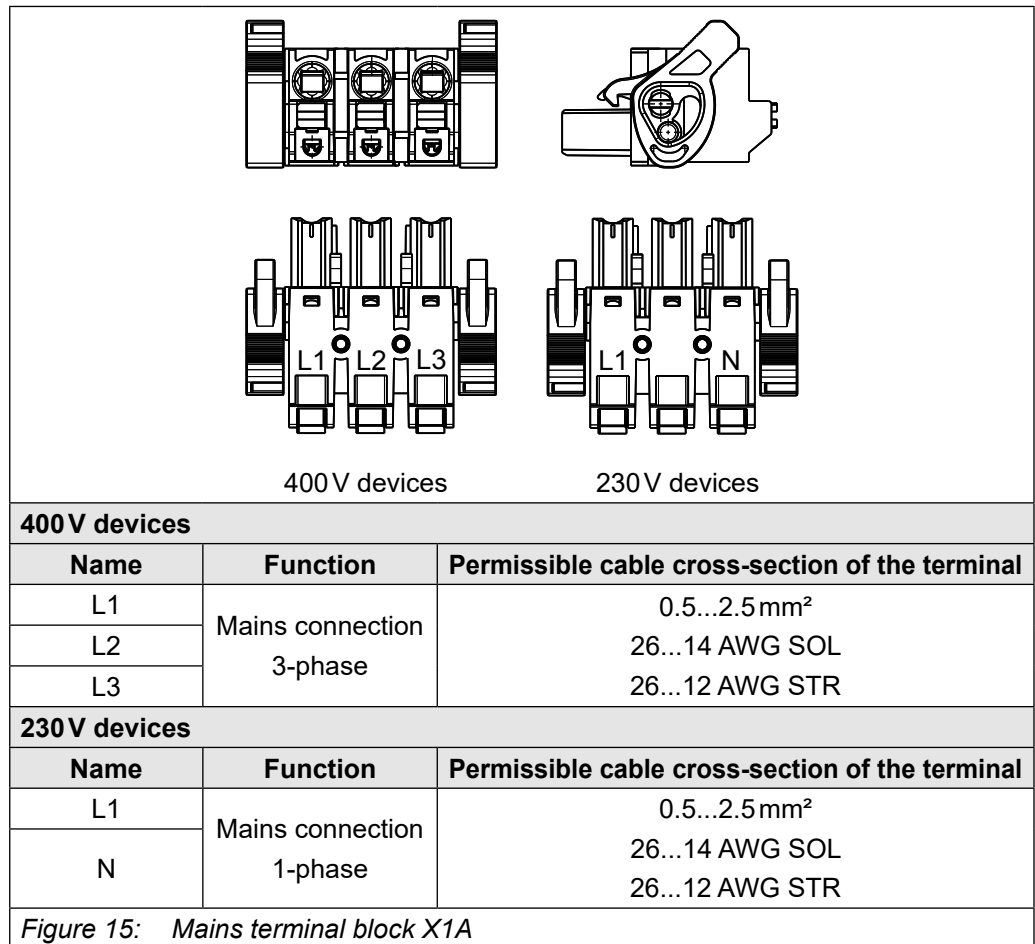

NOTICE

Pay attention to the connection cables!

- ▶ In UL-relevant applications, only multi-wire cables (strands) are permitted for devices of size 09 (1ph / 230V) at terminals X1A and X1B.

4.2.2 Leakage currents

Calculated maximum leakage currents depending on voltage and frequency.

Mains phases	Rated input voltage / V	Frequency / Hz	Leakage current / mA	
1-phase	230	50	3,6	
		60	4,3	
	265	Maximum input voltage / V	Frequency / Hz	Leakage current / mA
		50	4,1	
60	4,9			

Table 39: Leakage current 1-phase

Mains phases	Rated input voltage / V	Frequency / Hz	Leakage current / mA
3-phase	230	50 / 60	<5
	400		

Table 40: Leakage currents 3-phase



The specified leakage currents are calculated values in accordance with *DIN EN 60939-1*. The real leakage currents may deviate from the calculated values depending on the network conditions.

4.2.3 Protective und functional earth



Protective and functional earth must not be connected to the same terminal.

4.2.3.1 Protective earth

The protective earth (PE) serves for electrical safety particularly personal protection in error case.



Electric shock due to incorrect dimensioning!



► The earthing cross-section correspond to *VDE 0100* !

Name	Function	Terminal connection	Tightening torque
PE, ⊕	Connection for protective earth	Screw M4 for crimp connector	1.3 Nm 11 lb inch

Figure 16: Connection for protective earth

4.2.3.2 Functional earthing

A functional earthing may also be necessary, if for EMC requirements additional potential equalization between devices or parts of the system must be available.



The use of the functional earth (FE) is not required if the frequency inverter is EMC-technically wired.

The functional earth may not be wired green/yellow!



Notes on EMC-compatible installation can be found here.

www.keb.de/fileadmin/media/Manuals/emv/0000neb0000.pdf



4.2.4 AC mains connection

4.2.4.1 AC supply 230V/400V 3-phase

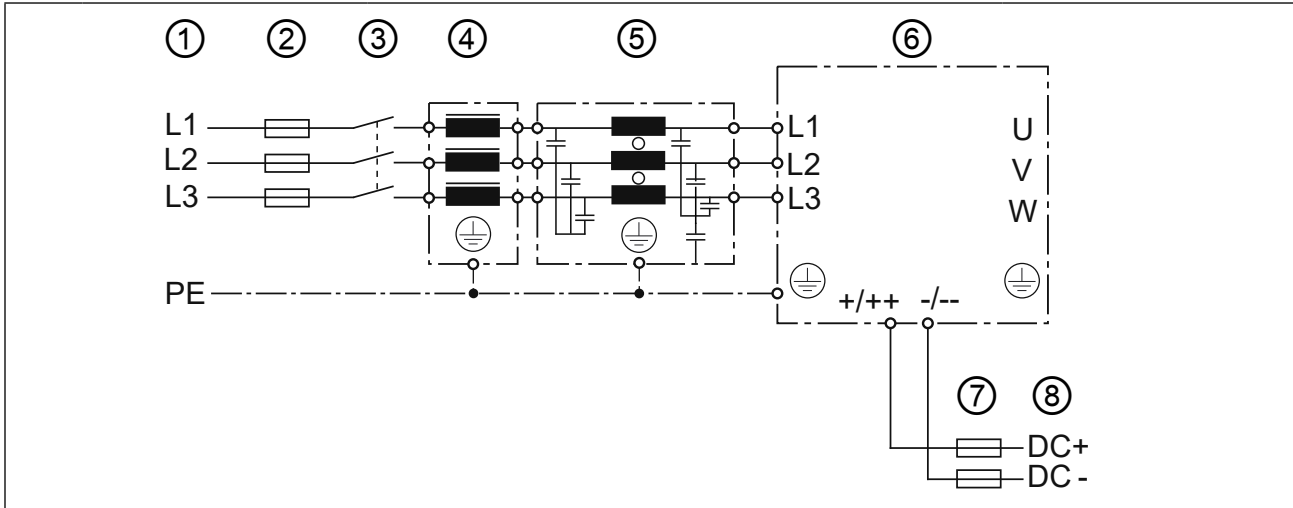

No.	Type	Description	
1	Mains voltage	3-phase 230/400VAC	
	Mains form	TN, TT	IT
		The rated voltage between one phase conductor and earth potential (or artificial neutral point in the IT mains) must not exceed 300V (effective value).	
Personal protection	RCMA with separator or RCD type B	Earth leakage monitor	
2	Mains fuses	Type gG	
3	Mains contactor	-	
4	Mains choke	=> „4.2.7.2 Conducted immunity depending on the motor cable length at AC supply“	
5	HF filter	Optional to observance the limit values according <i>EN 61800-3</i> for devices without internal filter	
6	KEB COMBIVERT	S6	
7	DC fuses	See note in chapter „Absicherung der Antriebsstromrichter“.	
8	DC supply	DC supply generated by the drive converter for connecting additional drive converters => „4.2.6 DC-bus connection“	

Figure 17: Connecting the mains supply of 3-phase devices

The service life of drive controllers with voltage DC link depends on the DC voltage, surrounding temperature and the current load of the electrolytic capacitors in the DC link. The use of mains chokes can increase the service life of the condensators to a considerable extent, especially when connecting to "hard" power systems or under permanent drive load (continuous duty). The term "hard" power system means that the nodal point power (S_{net}) of the mains is very high ($\gg 200$) compared to the rated apparent output power of the drive controller (S_{out}).

$k = \frac{S_{net}}{S_{out}} \gg 200$	e.g.	$k = \frac{2\text{MVA (supply transformer)}}{4\text{kVA (10S6)}} = 500 \rightarrow \text{Choke required}$
---------------------------------------	------	---

4.2.4.2 AC supply 230V 1-phase

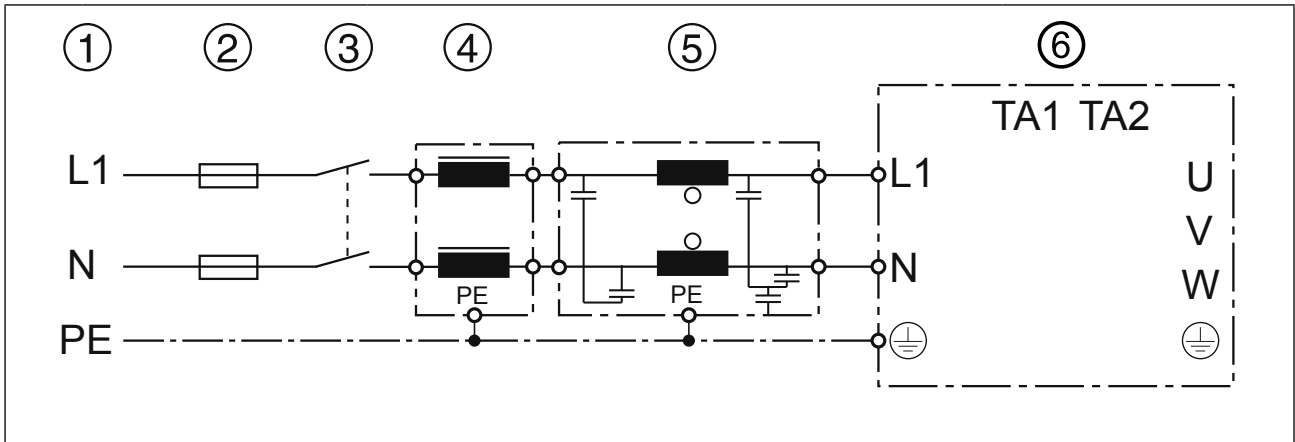

No.	Type	Description
1	Mains voltage	1-phase 230VAC
	Mains form	TN, TT
		IT
Personal protection	RCMA with separator or RCD type B	Earth leakage monitor
2	Mains fuses	Type gG
3	Mains contactor	
4	Mains choke	=> „4.2.7.2 Conducted immunity depending on the motor cable length at AC supply“
5	HF filter	Optional, for compliance with limit values according to EN 61800-3 for devices without an internal filter.
6	KEB COMBIVERT	S6

Figure 18: Connection of the mains supply 1-phase devices

The service life of drive controllers with voltage DC link depends on the DC voltage, surrounding temperature and the current load of the electrolytic capacitors in the DC link. The use of mains chokes can increase the service life of the condensators to a considerable extent, especially when connecting to "hard" power systems or under permanent drive load (continuous duty). The term "hard" power system means that the nodal point power (Snet) of the mains is very high (>> 200) compared to the rated apparent output power of the drive controller (Sout).

$k = \frac{S_{net}}{S_{out}} \gg 200$	e.g.	$k = \frac{2 \text{ MVA (supply transformer)}}{2.8 \text{ kVA (09S6)}} = 714 \rightarrow \text{Choke required}$
---------------------------------------	------	---

4.2.4.3 Supply cable

The conductor cross-section of the supply line is determined by the following factors:

- Input current of the drive controller
- Used cable type
- Installation method and ambient temperature
- The locally valid electrical regulations



The project engineer is responsible for the design!

4.2.5 DC mains connection

NOTICE

DC operation

- ▶ The DC voltage supply of 230V devices is only permitted after consultation with KEB!

4.2.5.1 DC supply

NOTICE

Destruction of the drive controller!

- ▶ Never swap “+ / ++” and “- / --”!

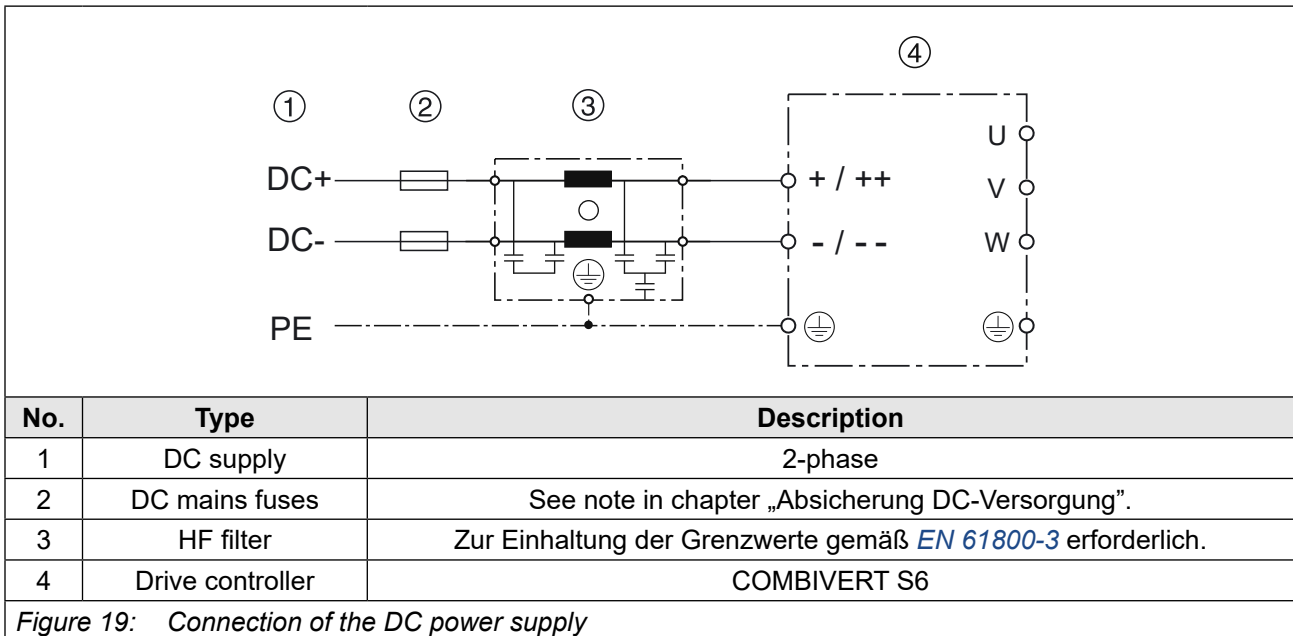

4.2.5.2 Terminal block X1B DC connection

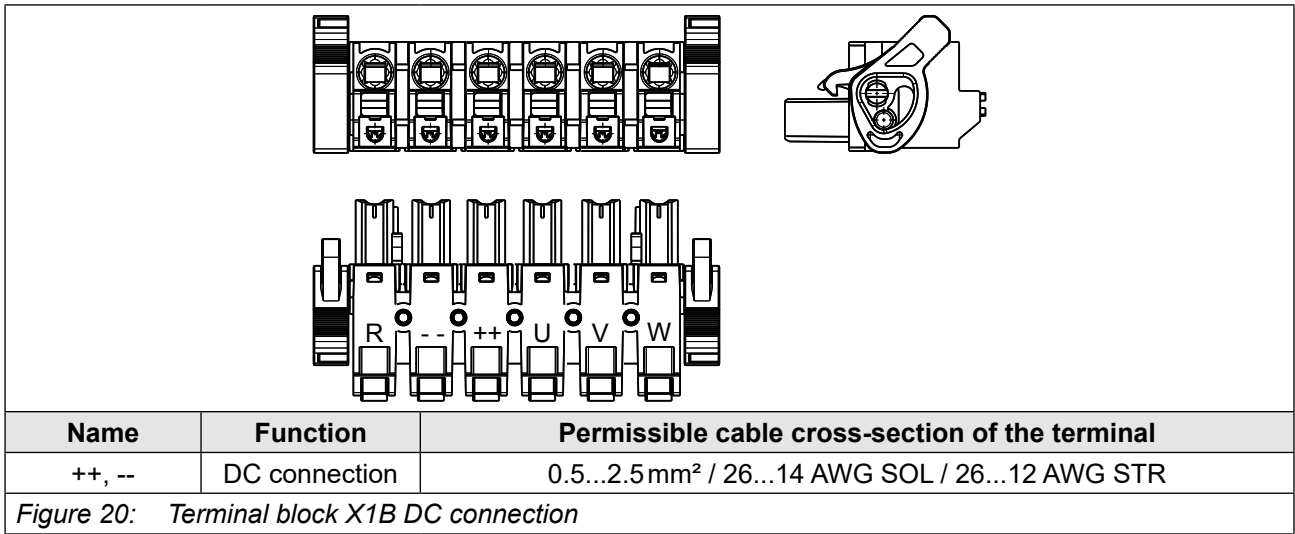

4.2.6 DC-bus connection

In a DC network, the intermediate circuits of several drive converters are coupled. This enables energy exchange between them and increases the energy efficiency of the application.

This drive converter can be supplied as part of a DC network either via the DC terminals => „4.2.5 DC mains connection“ or supply other drive converters via the DC terminals => . „4.2.4 AC mains connection“.



KEB has not tested the multitude of possible DC connections against the EMC product standard DIN EN IEC 61800-3. The CE conformity of the DC network is the responsibility of the user.

The following additional safety instructions must be observed when using this drive converter in a DC system:

- This drive converter may only be operated together with other F6 and S6 drive converters of the 400V class in a DC network.
- This drive converter must be installed in a housing.
- This drive converter must be protected with fuses at the DC terminals => „Table 34: Protection of drive converters with DC supply“.
- After a fuse in the DC system has blown due to a short circuit, all fuses in the DC system should be replaced due to the risk of damage.
- The parameterization of the input phase failure detection must be adjusted => S6 Programmierhandbuch.

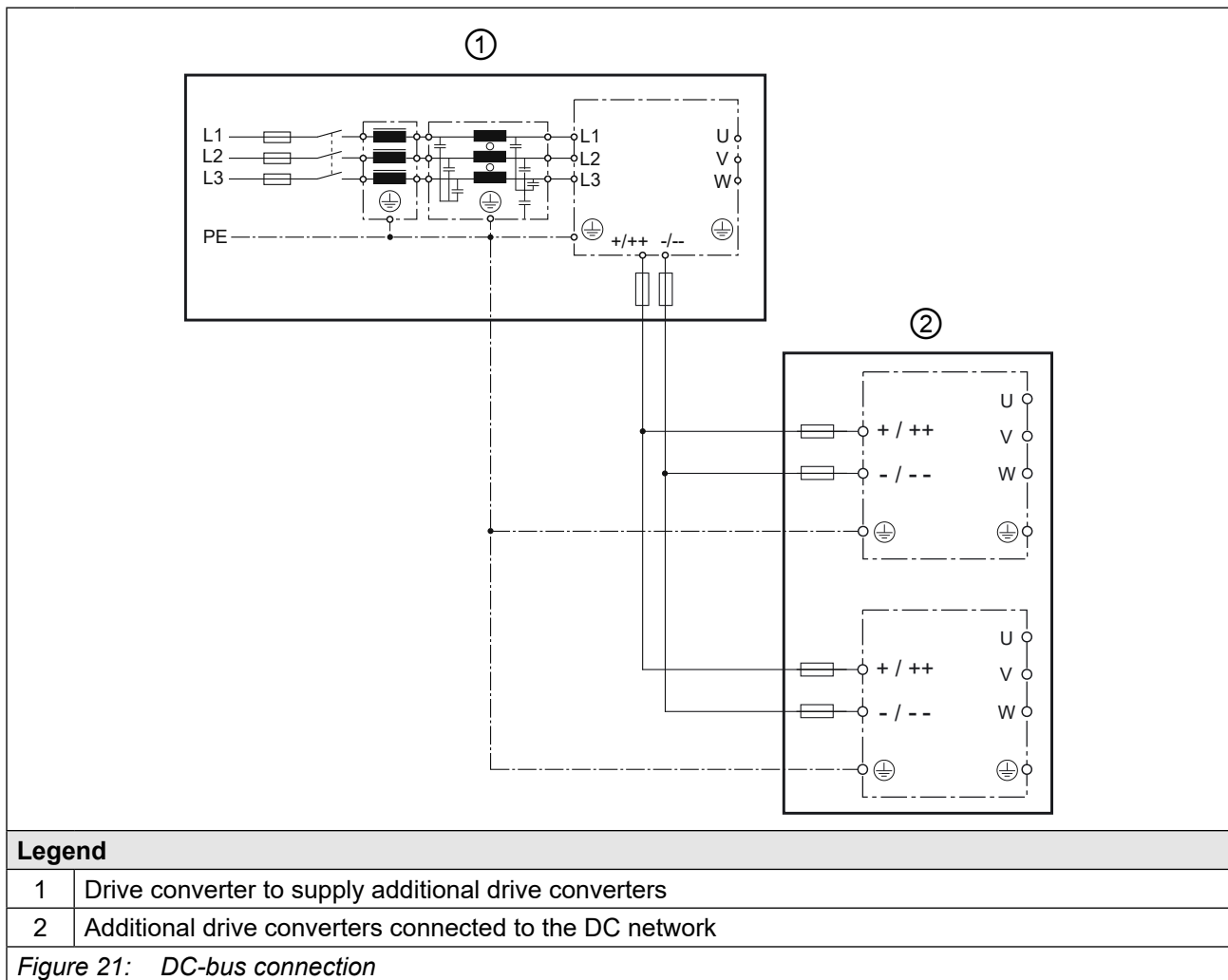

① When using this drive converter to supply additional drive converters via the DC terminals, the following must also be observed:

- The max. pre-charging current must not be exceeded => „Table 37: DC link / braking transistor function of the 400 V devices“.
- Each drive converter in the DC network must have an internal pre-charging circuit
- The user must prevent the rectifier from overloading => „Table 17: Overview of rectifier data for 400 V devices“.

4.2.7 Connection of the motor

4.2.7.1 Selection of the motor cable

The correct cabling as well as the motor cable plays an important part in case of low power in connection with long motor cable lengths. Ferrite cores and low-capacitance cables (phase/phase < 65 pF/m, phase/screen < 120 pF/m) at the output have the following effects:

- longer motor cable lengths
- less abrasion of the motor gearbox by leakage currents
- better EMC properties (reduction of the common-mode output currents to earth)

4.2.7.2 Conducted immunity depending on the motor cable length at AC supply

The maximum motor cable length is depending on the capacity of the cable as well as on the EMC emitted interference. The following data apply for operation under nominal rating conditions.

Voltage class	Device size	Max. motor cable length (shielded) in accordance with EN 61800-3 Category C2 Motor cable / m (low-capacitance)
230 V 1-phase	07	30
	09	
400 V 3-phase	07	50
	09	
	10	

Table 41: Maximum motor cable length at AC supply



The use of motor chokes or filters can significantly increase the cable length. KEB recommends the use of motor chokes or filters for a line length upto 50 m. Motor chokes or filters are absolutely necessary upto 100 m.

4.2.7.3 Motor cable length at operation with DC voltage

The maximum motor cable length at DC operation is basically dependent on the capacity of the motor cable. The internal filter is not active at DC operation. External measures must be taken if necessary. The following data apply for operation under nominal rating conditions.

Voltage class	Device size	Motor cable / m (low-capacitance)
230 V 1-phase	07	50
	09	
400 V 3-phase	07	50
	09	
	10	

Table 42: Maximum motor cable length at DC operation

4.2.7.4 Motor cable length for parallel operation of motors

The resulting motor cable length for parallel operation of motors, or parallel installation with multiple cables arises from the following formula:

$$\text{Resulting motor cable length} = \left(\sum_{l=1}^n \text{Motor cable lengths} \right) \cdot \sqrt{n} \text{ [Number of motor cables]}$$

4.2.7.5 Motor cable cross-section

The motor cable cross-section is dependent

- on the characteristic of the output current (e.g. not sine-wave).
- on the real effective value of the motor current.
- on the cable length.
- on the type of the used cable.
- on the ambient conditions such as bundling and temperature.

4.2.7.6 Interconnection of the motor

NOTICE

Protect motor against voltage peaks!

- ▶ Drive controllers switch at the output with $dV/dt \leq 5kV/\mu s$. Voltage peaks that endanger the insulation system at the motor can occur especially in case of long motor cables (> 15 m).
- ▶ A motor choke, a dV/dt -filter or sine-wave filter can be used for protection of the motor.

NOTICE

Faulty behaviour of the motor!

- ▶ The connecting-up instructions of the motor manufacturer are always generally valid.

4.2.7.7 Terminal block X1B motor connection

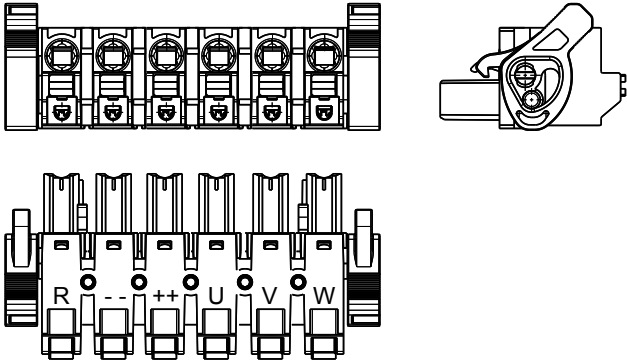

Name	Function	Permissible cable cross-section of the terminal
U, V, W	Motor connection	0.5...2.5 mm ² / 26...14 AWG SOL / 26...12 AWG STR

Figure 22: Terminal block X1B motor connection

4.2.7.8 Wiring of the motor

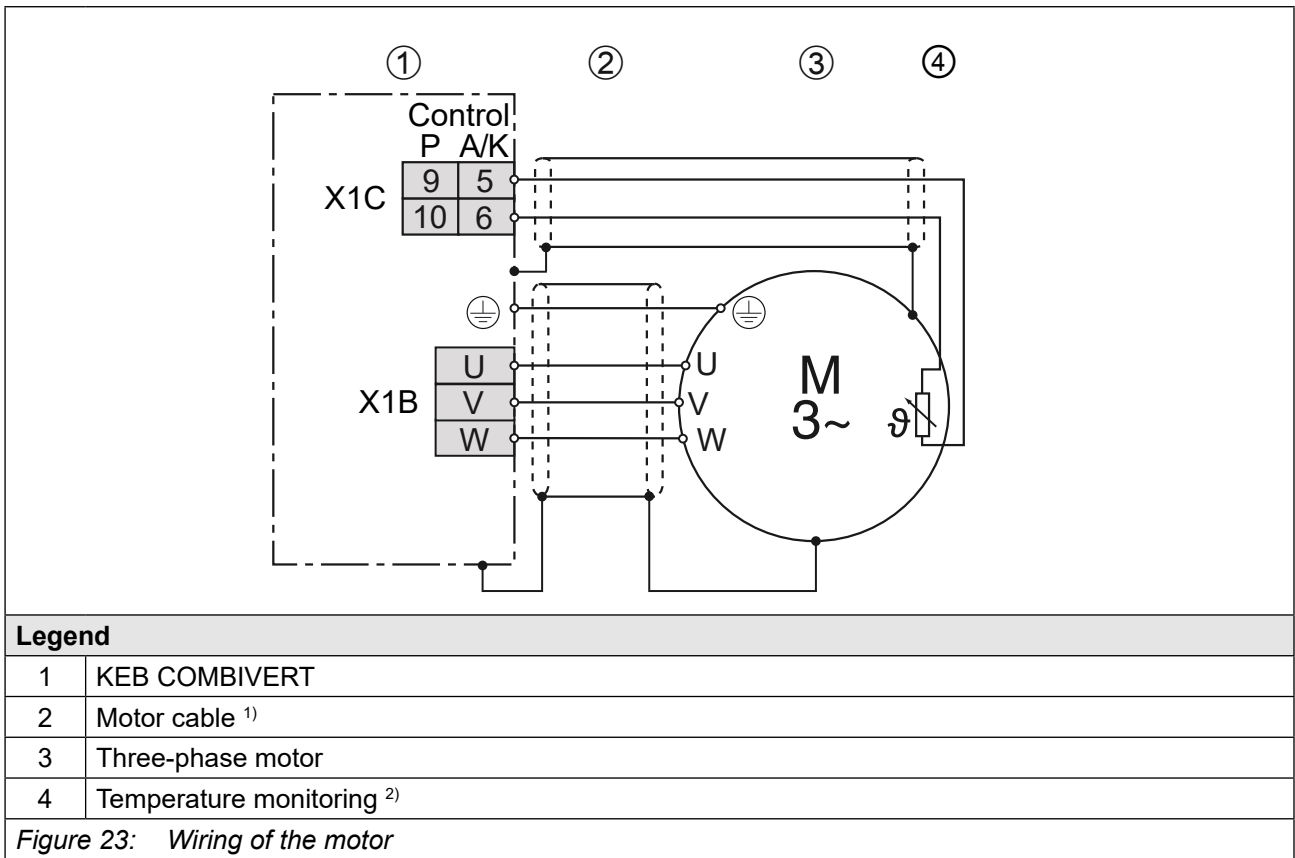

¹⁾ Apply the shield at both ends over a large area on the functional earth (shielding plate or mounting plate)

²⁾ Temperature monitoring is optionally available => [Instructions for use "Control unit"](#).

NOTICE

Connection of the temperature detection!

- ▶ Do not lay the connection cable of the motor temperature detection (also shielded) together with the control cable.
- ▶ The connection cable of the temperature detection inside the motor cable is only permissible with additional shielding (double shielding).
- ▶ The input of the temperature detection has basic isolation.

4.2.8 Connection of a braking resistor

⚠ CAUTION

Not fall below the minimum braking resistor value!

- ▶ Falling below the minimum braking resistor value destroys the braking transistor of the drive controller.

4.2.8.1 Terminal block X1B connection braking resistor

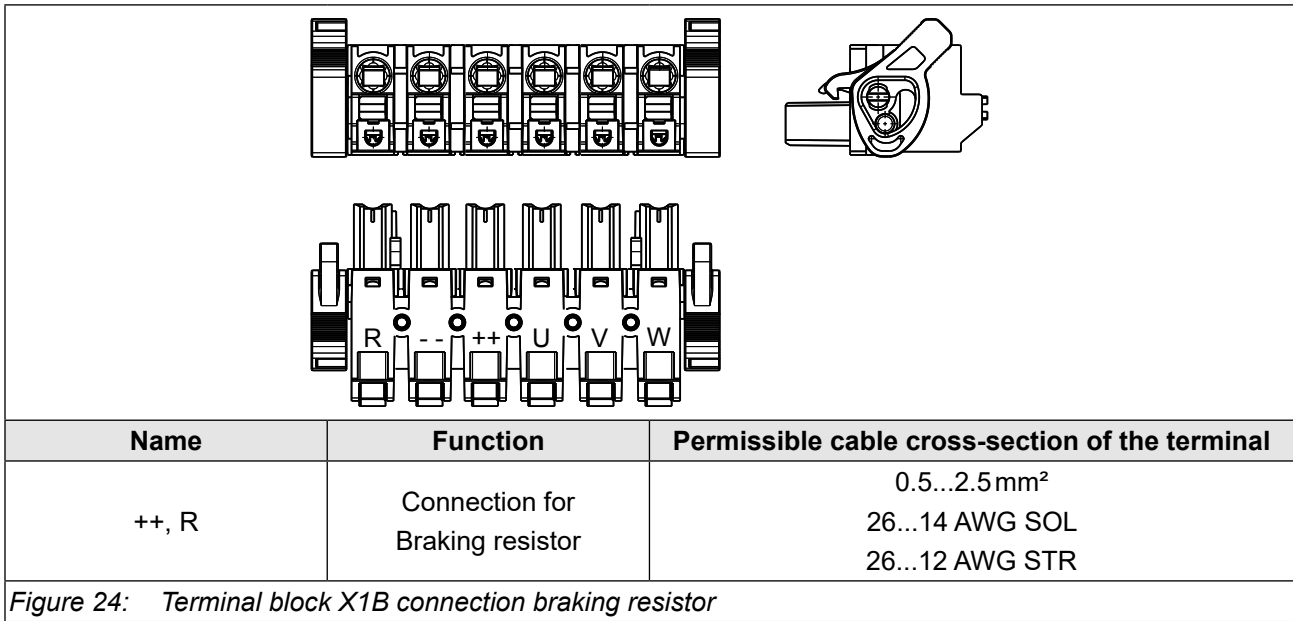

4.2.8.2 Use of intrinsically safe braking resistors

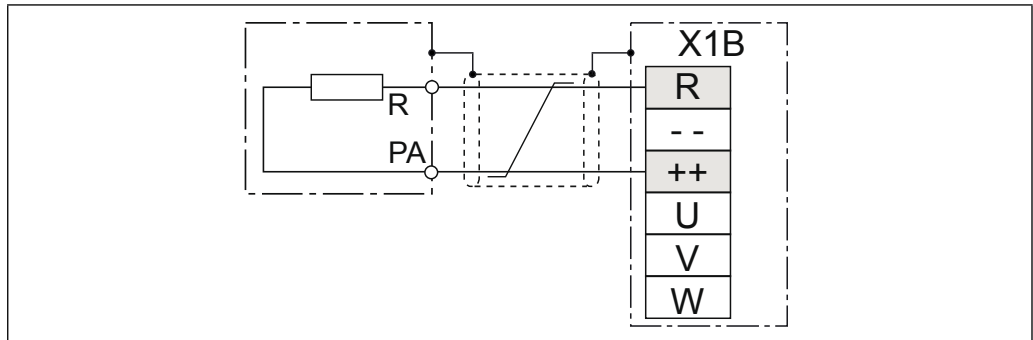

Figure 25: Wiring of an intrinsically safe braking resistor

NOTICE

Only intrinsically safe braking resistors permitted!

- ▶ Only "intrinsically safe" braking resistors are permitted for this operation, since these resistors interrupt themselves at fault such as safety fuse without fire risk.



Instructions for use "Installation of an intrinsically safe braking resistor"

www.keb.de/fileadmin/media/Manuals/dr/ma_dr_safe-braking-resistors-20106652_en.pdf



4.2.8.3 Use of non-intrinsically safe braking resistors

⚠ WARNING

Use of non-intrinsically safe braking resistors!

Fire or smoke development in case of overload or fault!



- ▶ Only use braking resistors with temperature sensor.
- ▶ Evaluate temperature sensor.
- ▶ Trigger fault on the drive controller (e.g. external input).
- ▶ Switch off input voltage (e.g. input contactor).
- ▶ Connection examples for non-intrinsically safe braking resistors => *Instructions for use "Installation braking resistors"*.



Instructions for use „Installation Braking Resistors“

www.keb.de/fileadmin/media/Manuals/dr/ma_dr_braking-resistors-20116737_en.pdf



4.3 Brake control and temperature detection for K- and A- control

X1C	PIN	Name	Notes
	1	BR+	Brake control / output +
	2	BR-	Brake control / output -
	3	Reserved	
	4	Reserved	
	5	TA1	Temperature detection / input+
	6	TA2	Temperature detection / input-

Figure 26: Assignment of the terminal block X1C for K- and A-control

4.3.1 Specification and connection of the brake control

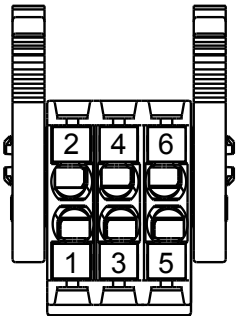
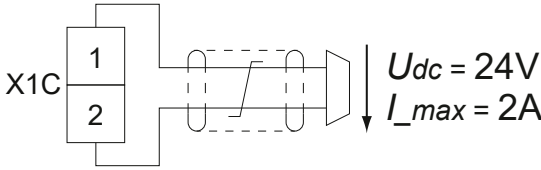

Name	BR+ (X1C.1); BR- (X1C.2)
Function	Output to supply a brake
Output voltage	<ul style="list-style-type: none"> • Minimum P24V_IN - 2.4V • Maximum P24V_IN
Maximum output current	2A
Others	Short-circuit proof, internal free-wheeling path; internal filter switching

Figure 27: Example for the connection of the brake output at X1C

4.3.2 Specification and connection of the temperature detection

⚠ DANGER

Use only sensors with basic insulation to mains potential !

Danger to life due to electric shock !

- ▶ The inputs of the temperature detection have „basic insulation“ against SELV voltage of the control.
- ▶ A system voltage (Phase – PE) of 300 V is defined.

NOTICE

Malfunctions due to incorrect cable or laying!

Malfunctions of the control due to capacitive or inductive coupling.

- ▶ Do not lay cables of the motor temperature sensor (also shielded) together with the control cable!
- ▶ Cables of the motor temperature sensor inside the motor cable only permissible with double shielding!

A switchable KTY84/PTC evaluation is implemented in the KEB COMBIVERT. The desired operating mode can be adjusted by software (dr33).

Operating mode (dr33)		Resistance	Temperature / state
0	KTY84/130	0.49 kΩ	0°C
		1 kΩ	100°C
		1.72 kΩ	200°C
1	PTC in accordance with <i>EN 60947-8</i> (standard)	< 0.75 kΩ	TA1-TA2 closed
		0.75...1.5 kΩ	Reset resistance
		1.65...4 kΩ	Tripping resistance
		> 4 kΩ	TA1-TA2 open
2	By encoder	digital by the encoder channel	
3	KTY83/110	0.82 kΩ	0°C
		1.67 kΩ	100°C
		2.53 kΩ	175°C
4	PT1000	1 kΩ	0°C
		1.38 kΩ	100°C
		1.75 kΩ	200°C
—	Monitoring	< 0,04 kΩ	Short circuit
		> 79,5 kΩ	No connection (sensor break)

Table 43: Specification of the temperature input for K- and A-control

4.3.3 Operation without temperature detection

Use of the COMBIVERT without evaluation of the temperature input:

- Deactivate the evaluation (pn33 =7)
- or
- Install bridge between terminal X1C.5 and X1C.6 (dr33=1)

4.3.4 Connection of a KTY sensor

NOTICE

No protection of the motor winding in case of wrong connection.

- ▶ Operate KTY sensors in forward direction. Non-observance leads incorrect measurement in the upper temperature range.
- ▶ KTY sensors may not be combined with other detections.

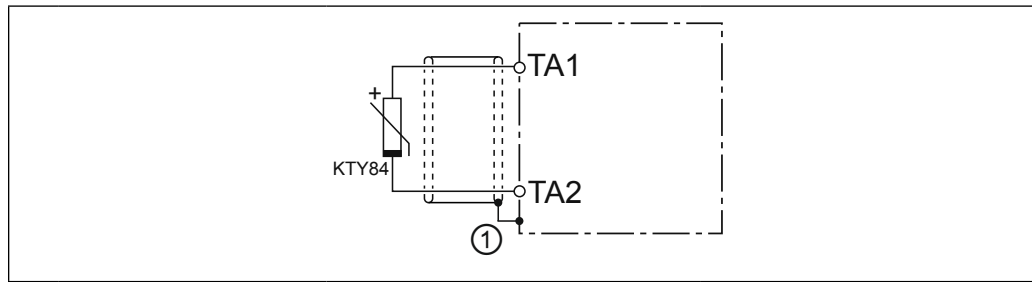

Name	Function	Stetting
TA1 (X1C.5); TA2 (X1C.6)	Temperature sensor input	dr33=0; KTY84/130 dr33=3; KTY83/110
1	Connection via shield plate ¹⁾	

Figure 28: Connection of a KTY sensor for K- and A-control

¹⁾ If not available, place on the mounting plate.

4.3.5 Connection of PTC, temperature switch or PT1000

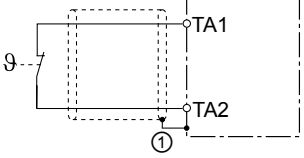
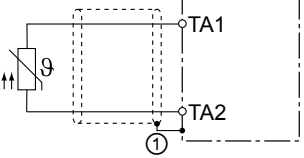
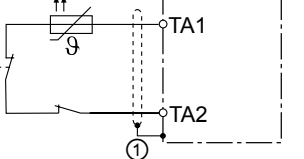
Thermal contact (NC contact)		
Temperature sensor (PTC) or PT1000		
Mixed sensor chain		
Name	Function	Setting
TA1 (X1C.5); TA2 (X1C.6)	Temperature sensor input	dr33=1; PTC or temperature switch dr33=4; PT1000
1	Connection via shield plate ¹⁾	
<i>Figure 29: Connection examples of different temperature sensors K/A</i>		

¹⁾ If not available, place on the mounting plate.

4.4 Brake control and temperature detection for P- control

X1C	PIN	Name	Notes
	1	BR+	Brake control / output
	2	BR-	Brake control / output
	3	0V	For supply of the feedback inputs P24Vin - 0.5V / max. 1A (BR+ and 24Vout in addition 2A)
	4	24Vout	
	5	DIBR1	Feedback input for brake control
	6	DIBR2	Feedback input for brake control
	7/8	reserved	
	9	TA1	Temperature detection / input+
	10	TA2	Temperature detection / input-

Figure 30: Assignment of the terminal block X1C for P-control

4.4.1 Specification and connection of the brake / relay control

Features of the control

- Safely control one brake/relay
- Control together two single brakes/relays; it must be the same brake/relay twice.
- Internal brake feedback without additional wiring or external via two digital brake inputs.
- Power reduction through pulse width modulated control.
- Rapid demagnetization with a counter voltage of 27.5V, maximum every 5s
- Current monitoring

The control, parameterization and reading of the feedback inputs of the brake is carried out via the integrated safety module. Corresponding wiring and parameterization suggestions are described in the safety manual type 5.

Name	BR+ (X1C.1); BR- (X1C.2)
Function	Output for control one/two brake(s) or relay(s)
DC output voltage	Minimum P24Vin -1,2V Maximum P24Vin
Maximum braking current	one brake: 2A two brakes: 2 x 1A
Others	Internal free-wheeling path; internal filter circuit; not short-circuit proof

Table 44: Specification of the brake control for P-control

NOTICE

Using a brake

- ▶ Choose the input voltage tolerance of the brake corresponding to the tolerance of the output voltage.

4.4.2 Specification and connection of the temperature detection

⚠ DANGER

Danger to life due to electric shock!

- ▶ Use only sensors with base insulation or safe separation!

NOTICE

Malfunctions due to incorrect cable or laying!

Malfunctions of the control due to capacitive or inductive coupling.

- ▶ Do not lay cables of the motor temperature sensor (also shielded) together with the control cable!
- ▶ Cables of the motor temperature sensor inside the motor cable only permissible with double shielding!

A switchable KTY84/PTC evaluation is implemented in the COMBIVERT. The desired operating mode can be adjusted by software (dr33).

Operating mode (dr33)		Resistance	Temperature / state
0	KTY84/130	0.49 kΩ	0°C
		1 kΩ	100°C
		1.72 kΩ	200°C
1	PTC in accordance with <i>EN 60947-8</i> (standard)	< 0.75 kΩ	TA1-TA2 closed
		0.75...1.5 kΩ	Reset resistance
		1.65...4 kΩ	Tripping resistance
		> 4 kΩ	TA1-TA2 open
2	By encoder	digital by the encoder channel	
3	KTY83/110	0.82 kΩ	0°C
		1.67 kΩ	100°C
		2.53 kΩ	175°C
4	PT1000	1 kΩ	0°C
		1.38 kΩ	100°C
		1.75 kΩ	200°C
—	Monitoring	< 0,04 kΩ	Short circuit
		> 79,5 kΩ	No connection (sensor break)

Table 45: Specification of the temperature input for P-control

4.4.2.1 Operation without temperature detection

Use of the COMBIVERT without evaluation of the temperature input:

- Deactivate the evaluation (pn12=7).
- or
- Install bridge between terminal TA1 (X1C.9) and TA2 (X1C.10) (dr33=1).

4.4.2.2 Connection of a KTY sensor

NOTICE

No protection of the motor winding in case of wrong connection.

- ▶ Operate KTY sensors in forward direction. Non-observance leads incorrect measurement in the upper temperature range.
- ▶ KTY sensors may not be combined with other detections.

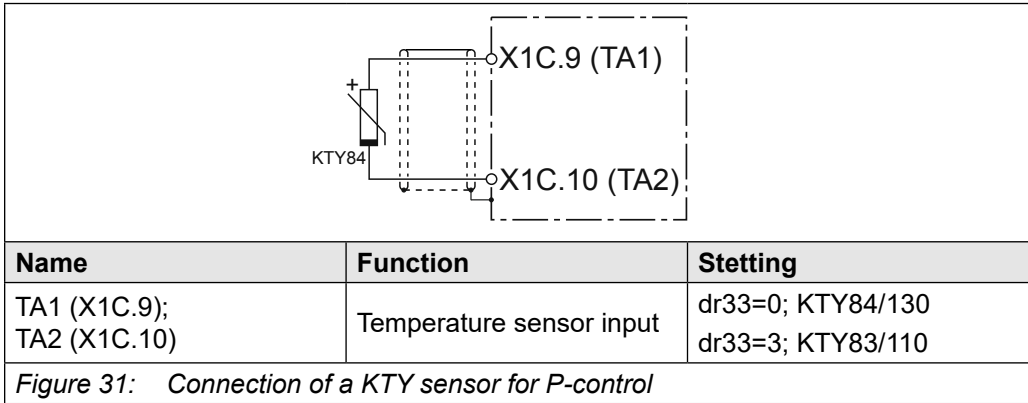

4.4.2.3 Connection of PTC, temperature switch or PT1000

Thermal contact (NC contact)		
Temperature sensor (PTC) or PT1000		
Mixed sensor chain		
Name	Function	Stetting
TA1 (X1C.9); TA2 (X1C.10)	Temperature sensor input	dr33=1; PTC or temperature switch dr33=4; PT1000
1	Connection via shield plate ¹⁾	
Figure 32: Connection examples of different temperature sensors for P-control		

¹⁾ If not available, place on the mounting plate.

5 Certification

5.1 CE marking

The drive controller marked with a CE logo comply with the requirements specified by European Union directives. The CE Declaration of Conformity is available on the Internet at www.keb-automation.com/search.



For further information regarding the CE declarations of conformity.

=> „5.5 Further informations and documentation“

5.2 Functional safety

Drive controllers with functional safety are marked with the FS logo on the nameplate. These devices are designed and manufactured in accordance with the Machine Directive. Die harmonisierte Norm der Reihe [EN 61800-5-2](#) wird angewendet.

5.3 Annex to the declaration of conformity

Annex to the EC declaration of conformity for systems with functional safety:

Product designation:	Drive controller - series	xxS6xxx-xxxx
	Dimension	07 - 14
	Voltage class	200 V / 400 V

Hereby we declare that the safety component specified above complies with all relevant regulations of the machine directive.

The safety component specified above meets the requirements of the following guidelines and standards:

- Machine directive 2006/42/EC
- EMC directive 2014/30/EU
- Low-Voltage Directive 2014/35/EU
- Hazardous substances 2011/65/EU

EN - Norm	Name	Reference
EN 61800-5-1	Electrical power drive systems with adjustable speed: Safety requirements	VDE 0160-105-1
EN 61800-2	Fundamental specifications for AC drive controllers	VDE 0160-102
EN 61800-3	Electrical power drive systems with adjustable speed. EMC requirements	VDE 0160-103
Especially for systems with functional safety additionally:		
EN 61800-5-2	Electrical power drive systems with adjustable speed: functional safety requirements	VDE 0160-105 -2
EN 61508-(1...7)	Functional safety of electrical/electronic programmable electronic safety-related systems	VDE 0803-1 ...7
EN 60204-1	Safety of machinery - Electrical equipment of machines Part1: General requirements	VDE 0113-1
EN 62061	Safety of machinery - Functional safety of electrical, electronic and programmable electronic control systems	VDE 0113 -50
EN 13849-1	Safety of machinery - Safety-related parts of control systems	–
<i>Table 46: Applied standards</i>		

The conformity was confirmed by the TÜV Rheinland with the EC-type examination certificate 01/205/5421.00/14.

The number/address of the indicated constitution:

NB 0035

TÜV Rheinland Industrie Service GmbH

Alboinstr. 56,

12103 Berlin

Germany

Tel.: +49 30 7562-1557

Fax: +49 30 7562-1370

E-Mail: tuvat@de.tuv.com

5.4 UL Marking

	<p>Acceptance according to UL is marked at KEB drive controllers with the adjacent logo on the nameplate.</p>	<p>UL file number E167544</p>
--	---	-----------------------------------

To be conform according to UL for use on the North American and Canadian Market the following additionally instructions must be observed (original text of the UL-File):

- Only for use in grounded WYE supply sources.
- Rating of relays on Control Board A or Control Board K (30Vdc.:1A).
- Maximum Surrounding Air Temperature 45°C.
- Internal Overload Protection Operates prior to reaching the 200% of the Motor Full Load Current.
- S6, Housing Size 2 (1 phase Models 07S6 and 09S6):
Suitable For Use On A Circuit Capable Of Delivering Not More Than 5000 rms Symmetrical Amperes, yyy Volts Maximum when protected by CC or J Class Fuses or by a Manual Motor Controller,type E as specified in the instruction manual

S6, Housing Size 2 (1 phase Models: 07S6 and 09S6):

Suitable For Use On A Circuit Capable Of Delivering Not More Than 30000 rms Symmetrical Amperes, yyy Volts Maximum when protected by CC Class Fuses as specified in the instruction manual

S6, Housing Size 2(3 phase Models: 07S6,09S6 and 10S6):

Suitable For Use On A Circuit Capable Of Delivering Not More Than 30000 rms Symmetrical Amperes, xxx Volts Maximum when protected by CC Class Fuses or by Manual Motor Controllers type E „, see instruction manual for Branch Circuit Protection details.

S6, Housing Size 2 (3 phase Models: 07S6,09S6 and 10S6): „Suitable For Use On A Circuit Capable Of Delivering Not More Than 5000 rms Symmetrical Amperes, 480 Volts Maximum when protected by Circuit Breakers“, see instruction manual for Branch Circuit Protection details „.

Where:

xxx = 230V for 200-230V models and 480V for 480V models

yyy = 120V for 120V models and 230V for 230V models

- Integral solid state short circuit protection does not provide branch circuit protection. Branch circuit protection must be provided in accordance with the Manufacturer Instructions, National Electrical Code, the Canadian Electrical code, part I, and any additional local codes.
- Use in a Pollution Degree 2 environment.
- Terminals X1A/X1B: Housing size 2, model 09S6, single phase 230V units: “only for use with stranded wires”
- Use 60/75°C Copper Conductors Only.
- During the UL evaluation, only Risk of Electrical Shock and Risk of Fire aspects were investigated. Functional Safety aspects were not evaluated.

continued on the next page

- Wiring Terminals marked to indicate proper connections for the power supply, load and control circuit.
- WARNING – The opening of the branch circuit protective device may be an indication that a fault current has been interrupted. To reduce the risk of fire or electrical shock, current-carrying parts and other components of the controller should be examined and replaced if damaged. If burnout of the current element of an overload relay occurs, the complete overload relay must be replaced.

AVERTISSEMENT – LE DÉCLENCHEMENT DU DISPOSITIF DE PROTECTION DU CIRCUIT DE DÉRIVATION PEUT ÊTRE DÛ À UNE COUPURE QUI RÉSULTE D'UN COURANT DE DÉFAUT. POUR LIMITER LE RISQUE D'INCENDIE OU DE CHOC ÉLECTRIQUE, EXAMINER LES PIÈCES PORTEUSES DE COURANT ET LES AUTRES ÉLÉMENTS DU CONTRÔLEUR ET LES REMPLACER S'ILS SONT ENDOMMAGÉS. EN CAS DE GRILLAGE DE L'ÉLÉMENT TRAVERSÉ PAR LE COURANT DANS UN RELAIS DE SURCHARGE, LE RELAIS TOUT ENTIER DOIT ÊTRE REMPLACÉ.

Devices 07, 09 and 10 / 480V – housing 2 have been evaluated for connecting to DC voltage, supplied by other KEB inverters to a DC bus capacitance as follows:

Cat. No.	Housing	Min. capacitance	Max. capacitance
07S6	02	235uF	18600 uF
09S6			
10S6			

Cat. No.	Housing	DC voltage	Full Load Current
07S6	02	680 V	3.6 A
09S6			5.8 A
10S6			8 A

Branch Circuit Protection for series S6 housing size 2

I) Class CC fuses; not more than 30000 rms Symmetrical Amperes (SCCR 30kA):

Cat. No.	Housing	Input Voltage [Vac]	maximum Fuse size [A]
07S6	02	200-230 / 3ph	6
09S6			10
10S6		480 / 3ph	10

The voltage rating of the external fuses shall be at least equal to the input voltage of the drives.

Class CC or Class J, not more than 5000 rms Symmetrical Amperes (SCCR 5000):

Class CC not more than 30000 rms Symmetrical Amperes (SCCR 30000):

Cat. No.	Housing	Input Voltage [Vac]	maximum Fuse size [A]
07S6	02	120-230 / 1ph	15
09S6			20

II) Listed (NKHJ, NKHJ7/CSA Certified), Type E Self Protected Manual Motor Controllers, Type and manufacturer and electrical ratings as specified below:

120-230V/1ph S6 Models:

Manual Motor Controller; not more than 5000 rms Symmetrical Amperes (SCCR 5kA):

Cat. No.	Housing	Manufacturer	Type	Rating
07S6	02	Eaton	PKZM0 20-E	115V/1ph, 1.5 hp
09S6				230V/1ph, 3hp

200-230V/3ph S6 Models:

Manual Motor Controller; not more than 30000 rms Symmetrical Amperes (SCCR 30kA):

Cat. No.	Housing	Manufacturer	Type	Rating
07S6	02	Eaton	PKZM0 10-E	200V-230V/3ph, 3 hp
09S6				
10S6				

480V Models/3ph S6 Models:

Manual Motor Controller; not more than 30000 rms Symmetrical Amperes (SCCR 30kA):

Cat. No.	Housing	Manufacturer	Type	Rating
07S6	02	Eaton	PKZM0 10-E	480Y/277V/3ph, 7.5 hp
09S6				
10S6				

III) Listed (DIVQ, DIVQ7/CSA Certified), Listed Circuit Breaker, Type and manufacturer and electrical ratings as specified below:

480V Models/3ph S6 Models:

Cat. No.	Housing	Manufacturer	Type	Rating
07S6	02	Siemens	5SJ4310-7HG42	480Y/277Vac 10A
09S6				
10S6				

Following models were investigated for use with DC supply at their DC terminals:

DC Circuit Protection for series S6 housing size 2

480V/3ph Models:

Cat. No.	Housing	Manufacturer	Type	Rating
07S6	02	SIBA	50 118 06.08	700V / 8A
09S6			50 118 06.12	700V / 12A
10S6			50 118 06.16	700V / 16A

5.5 Further informations and documentation

You find supplementary manuals and instructions for the download under www.keb-automation.com/search

General instructions

- EMC and safety instructions
- Manuals for additional control boards, safety modules, fieldbus modules, etc.

Instruction and information for construction and development

- Input fuses in accordance with UL
- Programming manual for control and power unit
- Motor configurator to select the appropriate drive controller and to create downloads for parameterizing the drive controller

Approvals and approbations

- Declaration of conformity CE
- TÜV certificate
- FS certification

Other markings and approvals not listed here are identified by a corresponding logo on the rating plate or device, if applicable. The corresponding certificates are available on our website.

Others

- COMBIVIS, the software for comfortable parameterization of drive controllers via PC (available per download)
- EPLAN drawings

6 Revision history

Version	Date	Description
00	2014-08	Preliminary version
01	2014-12	1st released version
02	2015-01	Fuse type class cc added to UL description
03	2015-05	Devices without internal filter registered; preface changed
04	2015-11	General technical data completely revised, power dissipation added, UL description extended
05	2017-07	Change to new CI-optics, revision of the device data, change of the overview, adjustment of the backup data
06	2018-11	230 V variant added, terminal block X1C included
07	2019-02	Leakage currents for 230V class included
08	2019-04	Reduction of leakage current < 5 mA inserted; Type code revised
09	2019-12	Adjustments of the type code, editorial changes
10	2020-11	Inserting the installation depth
11	2021-05	Insertion of the chapter "Leakage currents", editorial changes
12	2023-05	Adjustments in fusing, editorial changes
13	2023-11	General update, error correction
14	2024-02	Technical specifications of the terminals adapted
15	2025-05	Description of 400 V DC-Ready devices included, glossary and standards updated. Editorial changes.
16	2025-07	Error correction
17	2025-12	Motor protection switch added, editorial changes
18	2026-05	Nameplate renewed, certification updated, editorial changes.

Glossary

0V	Earth-potential-free common point	Encoder emulation	Software-generated encoder output
1ph	1-phase mains	End customer	The end customer is the user of the customer product
3ph	3-phase mains	Endat	Bidirectional encoder interface of the company Heidenhain
AC	AC current or voltage	EtherCAT	Real-time Ethernet bus system of the company Beckhoff
AFE	From 07/2019 AIC replaces the previous name AFE	Ethernet	Real-time bus system - defines protocols, plugs, types of cables
AFE filter	From 07/2019 AIC filter replaces the previous name AFE filter	FE	Functional earth
AIC	Active Infeed Converter	FSoE	Functional Safety over Ethernet
AIC filter	Filter for Active Infeed Converter	FU	Drive controller
Application	The application is the intended use of the KEB product	GND	Reference potential, ground
ASCL	Asynchronous sensorless closed loop	GTR7	Braking transistor
Auto motor ident.	Automatically motor identification; calibration of resistance and inductance	HF filter	KEB specific term for an EMC filter (for description see EMC filter).
AWG	American wire gauge	Hiperface	Bidirectional encoder interface of the company Sick-Stegmann
B2B	Business-to-business	HMI	Human machine interface (touch screen)
BiSS	Open source real-time interface for sensors and actuators (DIN 5008)	HSP5	Fast, serial protocol
CAN	Fieldbus system	HTL	Incremental signal with an output voltage (up to 30V) -> TTL
c.d.f.	Cyclic duration factor	IEC	IEC xxxxx stands for an international standard of the International Electrotechnical Commission
CDM	Complete drive module including auxiliary equipment (control cabinet)	IPxx	Protection class (xx for class)
COMBIVERT	KEB drive controller	KEB product	The KEB product is subject of this manual
COMBIVIS	KEB start-up and parameterizing software	KTY	Silicium temperature sensor (polarized)
Customer	The customer has purchased a KEB product from KEB and integrates the KEB product into his product (customer product) or resells the KEB product (dealer)	Manufacturer	The manufacturer is KEB, unless otherwise specified (e.g. as manufacturer of machines, engines, vehicles or adhesives)
DC	DC current or voltage	MCM	American unit for large wire cross sections
DI	Demineralized water, also referred to as deionized (DI) water	Modulation	Means in drive technology that the power semiconductors are controlled
DIN	German Institut for standardization	MTTF	Mean service life to failure
DS 402	CiA DS 402 - CAN device profile for drives	NHN	Standard elevation zero; based on the specified height definition in Germany (DHHN2016). The international data generally deviate from this by only a few cm to dm, so that the specified value can be applied to the regionally applicable definition.
ELV	Extra-low voltage	OC	Overcurrent
EMC filter	EMC filters are used to suppress conducted interferences in both directions between the drive controller and the mains	OH	Overheat
Emergency stop	Shutdown of a drive in emergency case (not de-energized)	OL	Overload
Emergency switching off	Switching off the voltage supply in emergency case		
EMS	Energy Management System		
EN	European standard		

GLOSSARY

OSSD	Output signal switching device; - an output signal that is checked in regular intervals on its shutdown. (safety technology)
PDS	Power drive system incl. motor and measuring probe
PE	Protective earth
PELV	Protective Extra Low Voltage
PFD	Term used in the safety technology (EN 61508-1...7) for the size of error probability
PFH	Term used in the safety technology (EN 61508-1...7) for the size of error probability per hour
PLC	Programmable logic controller
Pt100	Temperature sensor with $R_0=100\Omega$
Pt1000	Temperature sensor with $R_0=1000\Omega$
PTC	PTC-resistor for temperature detection
PWM	Pulse width modulation
RJ45	Modular connector with 8 lines
SCL	Synchronous sensorless closed loop
SELV	Safe extra-low voltage, unearthed
SIL	The safety integrity level is a measure for quantifying the risk reduction. Term used in the safety technology (EN 61508 -1...7)
SS1	Safety function „Safe stop 1“ in accordance with IEC 61800-5-2
SSI	Synchronous serial interface for encoder
STO	Safety function „Safe Torque Off“ in accordance with IEC 61800-5-2
TTL	Logic with 5 V operating voltage
USB	Universal serial bus
VARAN	Real-time Ethernet bus system

List of Figures

Figure 1:	Nameplate.....	21
Figure 2:	Dimensions built-in version housing 2	26
Figure 3:	Dimensions built-in version with accessories housing 2	27
Figure 4:	Mounting distances	28
Figure 5:	Control cabinet ventilation.....	28
Figure 6:	Installation depth.....	30
Figure 7:	Switch-off time t depending on the overload I/IN (OL) 400 V devices	39
Figure 8:	Switch-off time t depending on the overload I/IN (OL) 230 V devices	40
Figure 9:	Overload characteristic in the lower speed range (OL2).....	41
Figure 10:	Block diagram of the energy flow.....	50
Figure 11:	Switching behaviour of the fan.....	51
Figure 12:	Overview COMBIVERT S6	52
Figure 13:	Input wiring / drive controller type	54
Figure 14:	Input circuit/drive controller type 230 V devices	54
Figure 15:	Mains terminal block X1A.....	55
Figure 16:	Connection for protective earth.....	56
Figure 17:	Connecting the mains supply of 3-phase devices	58
Figure 18:	Connection of the mains supply 1-phase devices	59
Figure 19:	Connection of the DC power supply	60
Figure 20:	Terminal block X1B DC connection.....	61
Figure 21:	DC-bus connection	62
Figure 22:	Terminal block X1B motor connection.....	64
Figure 23:	Wiring of the motor.....	65
Figure 24:	Terminal block X1B connection braking resistor	66
Figure 25:	Wiring of an intrinsically safe braking resistor.....	67
Figure 26:	Assignment of the terminal block X1C for K- and A-control	68
Figure 27:	Example for the connection of the brake output at X1C	68
Figure 28:	Connection of a KTY sensor for K- and A-control	70
Figure 29:	Connection examples of different temperature sensors K/A.....	71
Figure 30:	Assignment of the terminal block X1C for P-control	72
Figure 31:	Connection of a KTY sensor for P-control	74
Figure 32:	Connection examples of different temperature sensors for P-control.....	75

List of Tables

Table 1:	Type code	20
Table 2:	Configurable options	22
Table 3:	Climatic environmental conditions	23
Table 4:	Mechanical environmental conditions	24
Table 5:	Chemical / mechanical active substances	24
Table 6:	Device classification.....	25
Table 7:	Electromagnetic compatibility	25
Table 8:	Mounting instructions for control cabinet installation	29
Table 9:	Overview device data of the 400 V devices	31
Table 10:	Input voltages and frequencies of the 400 V devices	32
Table 11:	Input voltages for DC operation of the 400 V devices	32
Table 12:	Output voltages and frequencies of the 400 V devices	32
Table 13:	DC switching level 400 V devices	32
Table 14:	Example for the calculation of the motor voltage	32
Table 15:	Input currents of the 400 V devices.....	33
Table 16:	Output currents of the 400 V devices	33
Table 17:	Overview of rectifier data for 400 V devices	33
Table 18:	Power loss of 400 V devices.....	34
Table 19:	Overview device data of the 230 V devices	35
Table 20:	Input voltages and frequencies of the 230 V devices	36
Table 21:	Output voltages and frequencies of the 230 V devices	36
Table 22:	DC switching level of the 230 V devices	36
Table 23:	Input currents of the 230 V devices.....	37
Table 24:	Output currents of the 230 V devices	37
Table 25:	Power dissipation 230 V devices	37
Table 26:	Frequency-dependent maximum current for device size 07 400 V devices.....	42
Table 27:	Frequency-dependent maximum current for device size 09 400 V devices.....	42
Table 28:	Frequency-dependent maximum current for device size 10 400 V devices.....	42
Table 29:	Frequency-dependent maximum current for device size 07 230 V devices.....	43
Table 30:	Frequency-dependent maximum current for device size 09 230 V devices.....	43
Table 31:	Switching frequency and temperature	44
Table 32:	Fuse protection of drive converters 400 V devices, 3-phase AC	45
Table 33:	Fuse protection of drive converters 230 V devices, 1-phase AC	45
Table 34:	Protection of drive converters with DC supply	46
Table 35:	Recommended motor protective circuit-breakers / circuit breakers for 400 V / 480 V appliances.....	47
Table 36:	Alternative motor protective circuit-breakers / circuit breaker for 400 V / 480 V appliances.....	48
Table 37:	DC link / braking transistor function of the 400 V devices.....	49
Table 38:	DC link / braking transistor function of the 230 V devices	49
Table 39:	Leakage current 1-phase	56
Table 40:	Leakage currents 3-phase	56

Table 41:	Maximum motor cable length at AC supply.....	63
Table 42:	Maximum motor cable length at DC operation.....	63
Table 43:	Specification of the temperature input for K- and A-control	69
Table 44:	Specification of the brake control for P-control	72
Table 45:	Specification of the temperature input for P-control.....	73
Table 46:	Applied standards	77



MORE KEB PARTNERS WORLDWIDE:

www.keb-automation.com/contact





Automation with Drive

www.keb-automation.com

KEB Automation KG Suedstrasse 38 D-32683 Barntrop Tel. +49 5263 401-0 E-Mail: info@keb.de