



COMBIVERT F6

INSTRUCTIONS FOR USE | INSTALLATION F6 HOUSING 4
PEAK POWER

Translation of the original manual
Document 20379969 EN 03





Preface

The hardware and software described in this document are products of KEB. The information contained in this document is valid at the time of publishing. KEB reserves the right to update this document in response to misprints, mistakes or technical changes.

Signal words and symbols

Certain procedures within this document can cause safety hazards during the installation or operation of the device. Refer to the safety warnings in this document when performing these procedures. Safety signs are also located on the device where applicable. A safety warning is marked by one of the following warning signs:

| | |
|--|--|
|  DANGER | Dangerous situation, which will cause death or serious injury if this safety warning is ignored. |
|  WARNING | Dangerous situation, which may cause death or serious injury if this safety warning is ignored. |
|  CAUTION | Dangerous situation, which may cause minor injury if this safety warning is ignored. |
| NOTICE | Situation, which can cause damage to property if this safety warning is ignored. |

RESTRICTION

Used when the following statements depend on certain conditions or are only valid for certain ranges of values.



Used for informational messages or recommended procedures.

More symbols

- ▶ This arrow starts an action step.
- / - Enumerations are marked with dots or indents.
- => Cross reference to another chapter or another page.



Note to further documentation.
<https://www.keb-automation.com/search>



Laws and guidelines

KEB Automation KG confirms with the EC declaration of conformity and the CE mark on the device nameplate that it complies with the essential safety requirements.

The EC declaration of conformity can be downloaded on demand via our website.

Warranty and liability

The warranty and liability on design, material or workmanship for the acquired device is given in the general sales conditions.



Here you will find our general sales conditions.

<https://www.keb-automation.com/terms-conditions>



Further agreements or specifications require a written confirmation.

Support

Although multiple applications are referenced, not every case has been taking into account. If you require further information or if problems occur which are not referenced in the documentation, you can request the necessary information via the local KEB agency.

The use of our units in the target products is outside of our control and therefore lies exclusively in the area of responsibility of the customer.

The information contained in the technical documentation, as well as any user-specific advice in spoken and written and through tests, are made to best of our knowledge and information about the intended use. However, they are regarded as being only informal and changes are expressly reserved, in particular due to technical changes. This also applies to any violation of industrial property rights of a third-party. Selection of our units in view of their suitability for the intended use must be done generally by the user.

Tests can only be done within the intended end use of the product (application) by the customer. They must be repeated, even if only parts of hardware, software or the unit adjustment are modified.

Copyright

The customer may use the instructions for use as well as further documents or parts from it for internal purposes. Copyrights are with KEB and remain valid in its entirety.

This KEB product or parts thereof may contain third-party software, including free and/or open source software. If applicable, the license terms of this software are contained in the instructions for use. The instructions for use are already available to you, can be downloaded free of charge from the KEB website or can be requested from the respective KEB contact person.

Other wordmarks or/and logos are trademarks (™) or registered trademarks (®) of their respective owners.

Table of Contents

| | |
|--|-----------|
| Preface | 3 |
| Signal words and symbols | 3 |
| More symbols..... | 3 |
| Laws and guidelines..... | 4 |
| Warranty and liability..... | 4 |
| Support | 4 |
| Copyright..... | 4 |
| Table of Contents | 5 |
| 1 Basic Safety Instructions | 9 |
| 1.1 Target group | 9 |
| 1.2 Transport, storage and proper use | 10 |
| 1.3 Installation | 11 |
| 1.4 Electrical connection | 12 |
| 1.4.1 EMC-compatible installation..... | 13 |
| 1.4.2 Voltage test..... | 13 |
| 1.4.3 Insulation measurement..... | 13 |
| 1.5 Start-up and operation | 14 |
| 1.6 Maintenance | 16 |
| 1.7 Repair | 16 |
| 1.8 Disposal | 17 |
| 2 Product Description | 18 |
| 2.1 Specified application | 18 |
| 2.1.1 Residual risks | 18 |
| 2.2 Unintended use | 18 |
| 2.3 Product features | 19 |
| 2.4 Part code | 20 |
| 2.5 Nameplate | 22 |
| 2.5.1 Configurable options | 23 |
| 3 Technical data | 24 |
| 3.1 Operating conditions | 24 |
| 3.1.1 Climatic environmental conditions..... | 24 |
| 3.1.2 Mechanical environmental conditions | 25 |
| 3.1.3 Further environmental operating conditions | 25 |
| 3.1.4 Electrical operating conditions..... | 26 |
| 3.1.4.1 Device classification | 26 |
| 3.1.4.2 Electromagnetic compatibility..... | 26 |
| 3.2 Device data of the 230 V peak power devices | 27 |
| 3.2.1 Overview of 230 V peak power devices | 27 |
| 3.2.2 Voltage and frequencies for 230V devices | 28 |

| | | |
|------------|--|-----------|
| 3.2.2.1 | Example of the calculation of the possible motor voltage 230V | 29 |
| 3.2.3 | Input and output currents/overload for 230 V peak power devices | 29 |
| 3.2.3.1 | Overload characteristic (OL) for 230 V peak power devices | 30 |
| 3.2.3.2 | Frequency-dependent maximum current (OL2) for 230 V Peak Power devices | 32 |
| 3.2.4 | Power dissipation at rated operation of the 230 V peak power devices | 36 |
| 3.2.5 | Fusing for 230 V peak power devices | 36 |
| 3.3 | Device data of the 400 V peak power devices | 37 |
| 3.3.1 | Overview of 400 V peak power devices | 37 |
| 3.3.2 | Voltage and frequencies for 400V devices | 38 |
| 3.3.2.1 | Example of the calculation of the possible motor voltage: | 39 |
| 3.3.3 | Input and output currents/overload for 400 V peak power devices | 39 |
| 3.3.3.1 | Overload characteristic (OL) for 400 V peak power devices | 40 |
| 3.3.3.2 | Frequency-dependent maximum current (OL2) for 400 V Peak Power devices | 42 |
| 3.3.4 | Overview of rectifier data for 400 V devices | 45 |
| 3.3.5 | Power dissipation at rated operation of the 400 V peak power devices | 46 |
| 3.3.6 | Fusing for 400 V peak power devices | 46 |
| 3.3.6.1 | Fuse protection for AC supply | 46 |
| 3.3.6.2 | Fuse protection for DC supply | 47 |
| 3.3.6.3 | Motor protective circuit-breaker / circuit breaker | 48 |
| 3.4 | General electrical data | 50 |
| 3.4.1 | Switching frequency and temperature | 50 |
| 3.4.1.1 | Switching frequency and temperature of the 230 V peak power devices | 50 |
| 3.4.1.2 | Switching frequency and temperature of the 400 V peak power devices | 50 |
| 3.4.2 | DC link / braking transistor function | 51 |
| 3.4.2.1 | DC link / braking transistor function of the 230V peak power devices | 52 |
| 3.4.2.2 | DC link / braking transistor function of the 400V peak power devices | 53 |
| 3.4.3 | Fan | 53 |
| 3.4.3.1 | Switching behaviour of the fans | 54 |
| 3.4.3.2 | Switching points of the fans | 54 |
| 4 | Installation | 55 |
| 4.1 | Dimensions and weights | 55 |
| 4.1.1 | Built-in version air cooler | 55 |
| 4.1.2 | Push-through version air cooler IP20, IP54-ready | 56 |
| 4.2 | Control cabinet installation | 57 |
| 4.2.1 | Mounting instructions | 57 |
| 4.2.2 | Mounting distances | 58 |
| 4.2.3 | Installation of IP54-ready devices | 59 |
| 4.2.4 | Control cabinet ventilation | 60 |
| 4.2.5 | Airflow of the drive controller | 60 |

| | | |
|----------|---|-----------|
| 5 | Installation and connection | 61 |
| 5.1 | Overview of the COMBIVERT F6..... | 61 |
| 5.2 | Connection of the power unit..... | 64 |
| 5.2.1 | Connection of the voltage supply | 64 |
| 5.2.1.1 | Terminal block X1A..... | 65 |
| 5.2.2 | Protective earth and functional earth..... | 66 |
| 5.2.2.1 | Protective earth | 66 |
| 5.2.2.2 | Functional earthing..... | 66 |
| 5.3 | Mains connection | 67 |
| 5.3.1 | Supply cable..... | 67 |
| 5.3.2 | AC mains connection..... | 67 |
| 5.3.2.1 | AC supply 3-phase | 67 |
| 5.3.2.2 | Note on hard power systems..... | 68 |
| 5.3.3 | DC mains connection | 69 |
| 5.3.3.1 | Terminal block X1A DC connection | 69 |
| 5.3.3.2 | Connection at DC voltage supply | 70 |
| 5.3.4 | Connection of the motor | 71 |
| 5.3.4.1 | Wiring of the motor | 71 |
| 5.3.4.2 | Terminal block X1A motor connection | 72 |
| 5.3.4.3 | Selection of the motor line..... | 73 |
| 5.3.4.4 | Motor cable length and conducted interferences at AC supply | 73 |
| 5.3.4.5 | Motor cable length for parallel operation of motors | 74 |
| 5.3.4.6 | Motor cable cross-section | 74 |
| 5.3.4.7 | Interconnection of the motor..... | 74 |
| 5.3.4.8 | Connection of the temperature monitoring and brake control (X1C)..... | 75 |
| 5.3.5 | Connection and use of a braking resistor..... | 77 |
| 5.3.5.1 | Terminal block X1A connection braking resistor..... | 78 |
| 5.3.5.2 | Use of intrinsically safe braking resistors | 79 |
| 5.3.5.3 | Use of non-intrinsically safe braking resistors..... | 79 |
| 5.3.6 | DC-bus connection..... | 80 |
| 5.4 | Accessories | 82 |
| 5.4.1 | Filters and chokes | 82 |
| 5.4.2 | Shield connection bracket mounting kit..... | 82 |
| 5.4.3 | Seal IP54-ready devices | 82 |
| 5.4.4 | Side-mounted braking resistors..... | 82 |
| 6 | Approvals and certifications | 83 |
| 6.1 | CE marking..... | 83 |
| 6.2 | UL certification | 84 |
| 6.3 | Further informations and documentation | 86 |

| | |
|--------------------------------|-----------|
| 7 Revision history..... | 87 |
| Glossary | 88 |
| List of Figures..... | 90 |
| List of Tables..... | 91 |

1 Basic Safety Instructions

The products are designed and constructed in accordance with state-of-the-art technology and the recognized safety rules and regulations. However, the use of such devices may cause functional hazards for life and limb of the user or third parties, or damages to the system and other material property.

The following safety instructions have been created by the manufacturer for the area of electric drive technology. They can be supplemented by local, country- or application-specific safety instructions. This list is not exhaustive. Violation of the safety instructions by the customer, user or other third party leads to the loss of all resulting claims against the manufacturer.

NOTICE



Hazards and risks through ignorance!

- ▶ Read the instructions for use!
- ▶ Observe the safety and warning instructions!
- ▶ If anything is unclear, please contact KEB Automation KG!

1.1 Target group

This instruction manual is determined exclusively for electrical personnel. Electrical personnel for the purpose of this instruction manual must have the following qualifications:

- Knowledge and understanding of the safety instructions.
- Skills for installation and assembly.
- Start-up and operation of the product.
- Understanding of the function in the used machine.
- Detection of hazards and risks of the electrical drive technology.
- Knowledge of *VDE 0100*.
- Knowledge of national safety regulations.
-

⚠ DANGER



Interventions by unauthorized personnel!

Danger to life by electric shock and malfunction!

- ▶ Modification or repair is only permitted by KEB authorised personnel.

1.2 Transport, storage and proper use

The transport is carried out by qualified persons in accordance with the environmental conditions specified in this manual. Drive controller shall be protected against excessive strains.



Transport of drive controllers with an edge length >75 cm

The transport by forklift without suitable tools can cause a deflection of the heat sink. This leads to premature aging or destruction of internal components.

- ▶ Transport of drive controllers on suitable pallets.
- ▶ Do not stack drive controllers or burden them with other heavy objects.

NOTICE

Damage to the coolant connections

Bending of the tubes!

- ▶ Never place the device on the coolant connections

NOTICE

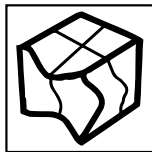

Behaviour in case of transport damage

- ▶ When receiving goods, check the device for transport damage such as deformations or loose parts.
- ▶ In case of damage, contact the carrier immediately.
- ▶ Do not operate the device in case of transport damage!



Drive controllers contain electrostatic sensitive components.

- ▶ Avoid contact.
- ▶ Wear ESD-protective clothing.

Do not store drive controllers

- in the environment of aggressive and/or conductive liquids or gases.
- with direct sunlight.
- outside the specified environmental conditions.

1.3 Installation

⚠ DANGER**Do not operate in an explosive environment!**

- ▶ The product is not intended for the use in potentially explosive environment.

⚠ CAUTION**Design-related edges and high weight!****Contusions and bruises!**

- ▶ Never stand under suspended loads.
- ▶ Wear safety shoes.
- ▶ Secure drive controller accordingly when using lifting gear.

To prevent damages to the device:

- Make sure that no components are bent and/or isolation distances are changed.
- The device must not be put into operation in case of mechanical defects.
- Do not allow moisture or mist to penetrate the unit.
- Avoid dust permeating the device. Allow for sufficient heat dissipation if installed in a dust-proof housing.
- Note installation position and minimum distances to surrounding elements. Do not cover the ventilation openings.
- Mount the drive controller according to the specified degree of protection.
- Make sure that no small parts fall into the product during assembly and wiring (drilling chips, screws etc.). This also applies to mechanical components, which can lose small parts during operation.
- Check the reliable fit of the device connections in order to avoid contact resistances and sparking.
- Do not walk-on drive controller.
- Follow all safety instructions!

1.4 Electrical connection

⚠ DANGER



Voltage at the terminals and in the device !

Danger to life due to electric shock !

- ▶ Never work on the open device or never touch exposed parts.
- ▶ For any work on the unit switch off the supply voltage, secure it against switching on and check absence of voltage by measuring at the input terminals.
- ▶ Wait until all drives has been stopped in order that no regenerative energy can be generated.
- ▶ Await capacitor discharge time (5 minutes). Check absence of voltage by measuring at the terminal block.
- ▶ If personal protection is required, install suitable protective devices for drive converters.
- ▶ Never bridge upstream protective devices (even for testing purposes).
- ▶ Connect the protective earth conductor always to drive converter and motor.
- ▶ Install all required covers and protective devices for operation.
- ▶ The control cabinet shall be kept closed during operation.
- ▶ Residual current: This product may cause a dc current in the protective earth conductor. When a residual current protective device (RCD) or a residual current monitoring device (RCM) is used for the protection against direct or indirect contact, only a RCD or RCM type B is permitted on the power supply side of this product.
- ▶ Drive converters with a leakage current > 3.5mA AC current (10mA DC current) are intended for a stationary connection. Protective earth conductors must be designed in accordance with the local regulations for equipment with high leakage currents according to *EN 61800-5-1*, *EN 60204-1* or *VDE 0100*.



If personnel protection is required during installation of the system, suitable protective devices must be used for drive controllers.

www.keb.de/fileadmin/media/Techinfo/dr/tn/ti_dr_tn-rcd-00008_en.pdf



Installations which include drive controller shall be equipped with additional control and protective devices in accordance with the relevant applicable safety requirements, e.g. act respecting technical equipment, accident prevention rules etc. They must always be complied with, also for drive controller bearing a CE marking.

For a trouble-free and safe operation, please pay attention to the following instructions:

- The electrical installation shall be carried out in accordance with the relevant requirements.
- Cable cross-sections and fuses must be dimensioned by the user according to the specified minimum/maximum values for the application.
- Connection of the drive converter is only permissible on symmetrical networks with a maximum line voltage (L1, L2, L3) with respect to earth (N/PE) of max. 300 V.
- With existing or newly wired circuits the person installing the units or machines must ensure that the PELV requirements are met.
- For drive converters that are not isolated from the supply circuit (in accordance with *EN 60721-3-2*) all control lines must be included in other protective measures (e.g. double insulation or shielded, earthed and insulated).
- When using components without isolated inputs/outputs, it is necessary that equipotential bonding exists between the components to be connected (e.g. by the equipotential line). Disregard can cause destruction of the components by equalizing currents.

1.4.1 EMC-compatible installation

Observance of the limit values required by EMC law is the responsibility of the customer.



Notes on EMC-compatible installation can be found here.

www.keb.de/fileadmin/media/Manuals/dr/emv/0000neb0000.pdf



1.4.2 Voltage test

Testing with AC voltage (in accordance with *EN 60204-1* chapter 18.4) may not be executed, since there is danger for the power semiconductors in the drive controller.



Due to the radio interference suppression capacitors, the test generator will switch off immediately with a current fault.



According to *EN 60204-1* it is permissible to disconnect already tested components. Drive controllers of the KEB Automation KG are delivered ex works voltage tested to 100% according to product standard.

1.4.3 Insulation measurement

An insulation measurement (in accordance with *EN 60204-1* chapter 18.3) with DC 500 V is permissible, if all power unit connections (grid-connected potential) and all control connections are bridged with PE. The insulation resistance of the respective device can be found in the technical data.

1.5 Start-up and operation

The start-up (i.e. for the specified application) is forbidden until it is determined that the installation complies with the machine directive; account is to be taken of [EN 60204-1](#).

⚠ WARNING

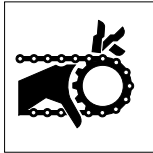

Software protection and programming!

Hazards caused by unintentional behavior of the drive!

- ▶ Check especially during initial start-up or replacement of the drive controller if parameterization is compatible to application.
- ▶ Securing a unit solely with software-supported functions is not sufficient. It is imperative to install external protective measures (e.g. limit switch) that are independent of the drive controller.
- ▶ Secure motors against automatic restart.

⚠ CAUTION



High temperatures at heat sink and coolant!

Burning of the skin!

- ▶ Cover hot surfaces safe-to-touch.
- ▶ If necessary, attach warning signs on the system.
- ▶ Before touching, check the surface and coolant lines.
- ▶ Before working let the unit cool down.

- During operation, all covers and doors shall be kept closed.
- Use only approved accessories for this device.
- Never touch terminals, busbars or cable ends.

⚠ WARNING



Triggering of overcurrent protection devices

Risk of fire or electric shock!

- ▶ Triggering of an overcurrent protection device will be a hint for an overload or short circuit. Triggering a RCD may be caused by a leakage current.
- ▶ In order to reduce the risk of fire or electric shock, live parts and other components of the controller should be checked and replaced in case of damage.
- ▶ If the contacts of an overload relay are burned, the complete relay must be replaced.

⚠ CAUTION

High sound level during operation!

Hearing damage possible!

- ▶ Wear hearing protection!

NOTICE

Continuous operation (S1) with load > 60% or from a rated motor power of 55kW!

Premature ageing of the electrolytic capacitors!

- ▶ Mains choke with $U_k = 4\%$ absolutely necessary.



If a drive controller with electrolytic capacitors in a DC link has not been in operation for more than one year, observe the following instructions.

www.keb.de/fileadmin/media/Techinfo/dr/tn/ti_dr_tn-format-capacitors-00009_en.pdf

**Switching at the output**

Switching between motor and drive controller is prohibited for single drives during operation as this may trigger the protection gear of the device. Function 'speed search' must be activated if switching can not be avoided. Speed search may only be triggered after closing the motor contactor (e.g. by switching the control release).

Connecting and disconnecting is permissible with multiple motor drives if at least 1 motor is running during the switch-over process. The drive controller must be dimensioned to the occurring starting currents.

The 'speed search' function must be activated if the motor is still running during a restart of the drive controller (mains on) (e.g. due to large rotating masses).

Switching at the input

For applications that require cyclic switching off and on of the drive controller, maintain an off-time of at least 5 min after the last switch on. If you require shorter cycle times please contact KEB Automation KG.

Short-circuit resistance

The drive converters are conditional short-circuit proof. After resetting the internal protection devices, the function as directed is guaranteed.

Exceptions:

- If an earth-leakage fault or short-circuit often occurs at the output, this can lead to a defect in the unit.
- If a short-circuit occurs during regenerative operation (2nd or 4th quadrant, regeneration into the DC link), this can lead to a defect in the unit.

1.6 Maintenance

The following maintenance work has to be carried out when required, but at least once per year by authorized and trained personnel. Check unit for loose screws and plugs and tighten if necessary.

- ▶ Check system for loose screws and plugs and tighten if necessary.
- ▶ Clean drive controller from dirt and dust deposits. Pay attention especially to cooling fins and protective grid of the fans.
- ▶ Examine and clean extracted air filter and cooling air filter of the control cabinet.
- ▶ Check the function of the fans of the drive controller. The fan must be replaced in case of audible vibrations or squeak.
- ▶ In the case of liquid-cooled drive controllers a visual test of the cooling circuit for leaks and corrosion must be carried out. The cooling circuit must be completely empty if a unit shall be switched off for a longer period. The cooling circuit must be blown out additionally with compressed air at temperatures below 0°C.

1.7 Repair

In case of malfunction, unusual noises or smells inform a person in charge!

⚠ DANGER



Unauthorized exchange, repair and modifications!

Unpredictable malfunctions!

- ▶ The function of the drive controller is dependent on its parameterization. Never replace without knowledge of the application.
- ▶ Modification or repair is permitted only by KEB Automation KG authorized personnel.
- ▶ Only use original manufacturer parts.
- ▶ Infringement will annul the liability for resulting consequences.

In case of failure, please contact the machine manufacturer. Only the machine manufacturer knows the parameterisation of the used drive controller and can provide an appropriate replacement or induce the maintenance.

1.8 Disposal

Electronic devices of the KEB Automation KG are exclusively professional devices for further industrial processing (so-called B2B devices).

Manufacturers of B2B devices are obliged to take back and recycle devices manufactured after 14.08.2018. These devices may not be disposed at the collection centres of public sector disposal organisations.



If no deviating agreement has been made between the customer and KEB or no deviating mandatory legal regulation exists, KEB products marked in this way can be returned. Company and keyword to the return point can be taken from the list below. Shipping costs are paid by the customer. Thereupon the devices will be professionally recycled and disposed.

The entry numbers are listed country-specific in the following table. The corresponding KEB return addresses can be found on our website.

| Withdrawal by | WEEE-Reg.-No. | Keyword |
|-------------------------|--------------------------|------------------------------------|
| Austria | | |
| KEB Automation GmbH | ERA: 51976 | Stichwort „Rücknahme WEEE“ |
| France | | |
| RÉCYLUM - Recycle point | ADEME: FR021806 | Mots clés „KEB DEEE“ |
| Germany | | |
| KEB Automation KG | EAR: DE12653519 | Stichwort „Rücknahme WEEE“ |
| Italy | | |
| COBAT | AEE: (IT) 19030000011216 | Parola chiave „Ritiro RAEE“ |
| Spain | | |
| KEB Automation KG | RII-AEE 7427 | Palabra clave „Retirada RAEE“ |
| Česko | | |
| KEB Automation KG | RETELA 09281/20 ECZ | Klíčové slovo: Zpětný odběr OEEZ |
| Slowakei | | |
| KEB Automation KG | ASEKOL: RV22EEZ0000421 | Klíčové slovo: "Spätný odber OEEZ" |

The packaging must be feed to paper and cardboard recycling.

2 Product Description

The device series COMBIVERT F6 concerns to drive controllers, which are optimized for operation at synchronous and asynchronous motors.

The COMBIVERT can be extended with a safety module for the use in safety-oriented applications. The COMBIVERT F6 series are drive controllers with functional safety, optimized for operation at synchronous and asynchronous motors.

Various safety functions are available for different applications. It can be operated with a fieldbus module at different fieldbus systems. The control board has a system comprehensive operating concept.

The COMBIVERT complies with the requirements of the Machinery Directive. The possible functions are certified via a type test.

The COMBIVERT is a product of limited availability in accordance with [EN 61800-3](#). This product may cause radio interference in residential areas. In this case the operator may need to take corresponding measures.

The Machinery Directive, EMC Directive, Low Voltage Directive and other directives and regulations must be observed

2.1 Specified application

The COMBIVERT serves exclusively for the control and regulation of three-phase motors. It is intended for the installation into electrical systems or machines in the industrie.

Technical data and information for connection conditions shall be taken from the nameplate and from the instructions for use and must be strictly observed.

The used semiconductors and components of the KEB Automation KG are developed and dimensioned for the use in industrial products.

Restriction

If the product is used in machines, which work under exceptional conditions or if essential functions, life-supporting measures or an extraordinary safety step must be fulfilled, the necessary reliability and security must be ensured by the machine builder.

2.1.1 Residual risks

Despite intended use, the drive controller can reach unexpected operating conditions in case of error, with wrong parameterization, by faulty connection or unprofessional interventions and repairs. This can be:

- wrong direction of rotation
- motor speed too high
- motor is running into limitation
- motor can be under voltage even in standstill
- automatic start

2.2 Unintended use

The operation of other electric consumers is prohibited and can lead to the destruction of the devices. The operation of our products outside the indicated limit values of the technical data leads to the loss of any liability claims.

2.3 Product features

These instructions for use describe the power units of the following devices:

| | |
|--------------|-------------------------------------|
| Device type: | Drive controller |
| Series: | COMBIVERT F6 |
| Power range: | 22...30 kW / 400 V 15 kW / 230 V |
| Housing: | 4 Peak Power |

The COMBIVERT F6 is characterized by the following features:

- Operation of three-phase asynchronous motors and three-phase synchronous motors, in operating modes open-loop or closed-loop with and without speed feedback
- Following fieldbus systems are supported:
EtherCAT, VARAN, PROFINET, POWERLINK or CAN
- System-overlapping operating concept
- Wide operating temperature range
- Low switching losses by IGBT power unit
- Low noise development due to high switching frequencies
- Different heat sink concepts
- Temperature-controlled fan, easily replaceable
- Torque limits and s-curves are adjustable to protect gearboxes
- General protection functions of the COMBIVERT series against overcurrent, over-voltage, ground fault and overtemperature
- Analog inputs and outputs, digital inputs and outputs, relay output (potential-free), brake control and -supply, motor protection by I^2t , KTY- or PTC input, two encoder interfaces, diagnostic interface, fieldbus interface (depending on the control board)
- Integrated safety function according to [EN 61800-5-2](#)

2.4 Part code

x x F 6 x x x - x x x x

Heat sink version

| |
|--|
| 1: Air-cooler, mounted version |
| 2: Liquid cooler (water), mounted version |
| 3: Air-cooler, through-mount version IP54-ready |
| 4: Liquid cooler (water), through-mount version IP54-ready |
| 5: Air-cooler, through-mount version IP20 |
| 6: Liquid cooler (water), trough-mount version IP54-ready, sub-mounted braking resistors |
| 7: Liquid cooler (oil), through-mount version IP54-ready |
| 8: Liquid cooler (oil), through-mount version IP54-ready, sub-mounted braking resistors |
| 9: Liquid cooler (water), mounted version, sub-mounted braking resistors |
| A: Liquid cooler (water), mounted version, High Performance, sub-mounted braking resistors |
| B: Liquid cooler (water), through-mount version, IP54-ready, High Performance, sub-mounted braking resistors |
| C: Air-cooler, mounted version, Version 2 |
| D: Air-cooler, mounted version, High-Performance |
| E: Liquid cooler (water), mounted version, High-Performance |
| F: Air-cooler, through-mount version IP54-ready, High-Performance |
| G: Liquid cooler (water), trough-mount version IP54-ready, High-Performance |
| H: Air-cooler,, Convektion, trough-mount version IP54-ready |

Control board variant

| |
|--|
| APPLIKATION |
| 1: Multi Encoder Interface, CAN ^{® 2)} , Real-Time Ethernet-busmodule ³⁾ |
| B Multi Encoder Interface, CAN ^{® 2)} , Real-Time Ethernet-busmodule ³⁾ , Alternative connector |
| KOMPAKT |
| 1: Multi Encoder Interface, CAN ^{® 2)} , STO, EtherCAT ^{® 1)} |
| 2: Multi Encoder Interface, CAN ^{® 2)} , STO, VARAN |
| PRO |
| 0: No Encoder, CAN ^{® 2)} , Real-Time Ethernetinterface ³⁾ |
| 1: Multi Encoder Interface, CAN ^{® 2)} , Real-Time Ethernet interface ³⁾ |
| 3: Multi Encoder Interface, CAN ^{® 2)} , Real-Time Ethernet interface ³⁾ , RS485-potential free |
| 4: No Encoder, CAN ^{® 2)} , Real-Time Ethernetinterface ³⁾ , safe relay |
| 5: Multi Encoder Interface, CAN ^{® 2)} , Real-Time Ethernet interface ³⁾ , safety relay |
| B: Multi Encoder Interface, CAN ^{® 2)} , Real-Time Ethernet interface ³⁾ , alternative connector |

continued on the next page

| | | | | | | | | | | | |
|---|---|---|---|---|---|---|---|---|---|--|---|
| x | x | F | 6 | x | x | x | - | x | x | x | |
| Switching frequency, Software current limit, Turn-off current | | | | | | | | | | 0: 2 kHz / 125% / 150% | 8: 2 kHz / 180% / 216% |
| | | | | | | | | | | 1: 4 kHz / 125% / 150% | 9: 4 kHz / 180% / 216% |
| Voltage / Connection type | | | | | | | | | | 2: 8 kHz / 125% / 150% | A: 8 kHz / 180% / 216% |
| | | | | | | | | | | 3: 16 kHz / 125% / 150% | B: 8 kHz / HSD |
| Housing | | | | | | | | | | 4: 2 kHz / 150% / 180% | C: 6 kHz / HSD |
| | | | | | | | | | | 5: 4 kHz / 150% / 180% | Non standard switching D: frequency / Overload characteristic |
| Equipment | | | | | | | | | | 6: 8 kHz / 150% / 180% | E: Special Device |
| | | | | | | | | | | 7: 16 kHz / 150% / 180% | |
| Control type | | | | | | | | | | 1: 3ph 230 V AC/DC with braking transistor | |
| | | | | | | | | | | 2: 3ph 230 V AC/DC without braking transistor | |
| Series | | | | | | | | | | 3: 3ph 400 V AC/DC with braking transistor | |
| | | | | | | | | | | 4: 3ph 400 V AC/DC without braking transistor | |
| Inverter size | | | | | | | | | | A: 3ph 400 V AC/DC incl. GTR7 / max. rectifier / max. pre-charging | |
| | | | | | | | | | | 5: 3ph 400 V AC/DC without GTR7 / max. rectifier / max. pre-charging | |
| Inverter size | | | | | | | | | | C: 3ph 400 V AC/DC. GTR7-variant 2 | |
| | | | | | | | | | | D: 3ph 400 V AC/DC GTR7-variant 2 / max. rectifier / max. pre-charging | |
| Inverter size | | | | | | | | | | 2...9 | |
| | | | | | | | | | | 1: Safety module type 1 /STO at control type K | |
| Inverter size | | | | | | | | | | 3: Safety module type 3 | |
| | | | | | | | | | | 4: Safety module type 4 | |
| Inverter size | | | | | | | | | | 5: Safety module type 5 | |
| | | | | | | | | | | A: APPLICATION | |
| Inverter size | | | | | | | | | | K: COMPACT | |
| | | | | | | | | | | P: PRO | |
| Inverter size | | | | | | | | | | COMBIVERT F6 | |
| | | | | | | | | | | 10...33 | |

Table 1: Part code

- 1) EtherCAT® is registered trademark and patented technology, licensed by Beckhoff Automation GmbH, Germany
- 2) CANopen® is registered trademark of CAN in AUTOMATION - International Users and Manufacturers Group e.V.
- 3) The Real-Time Ethernetbusmodul / Real-Time Ethernet interface contains various fieldbus control types which can be adjusted by software (parameter fb68)



The part code may not be used as order code, but only for identification!

2.5 Nameplate

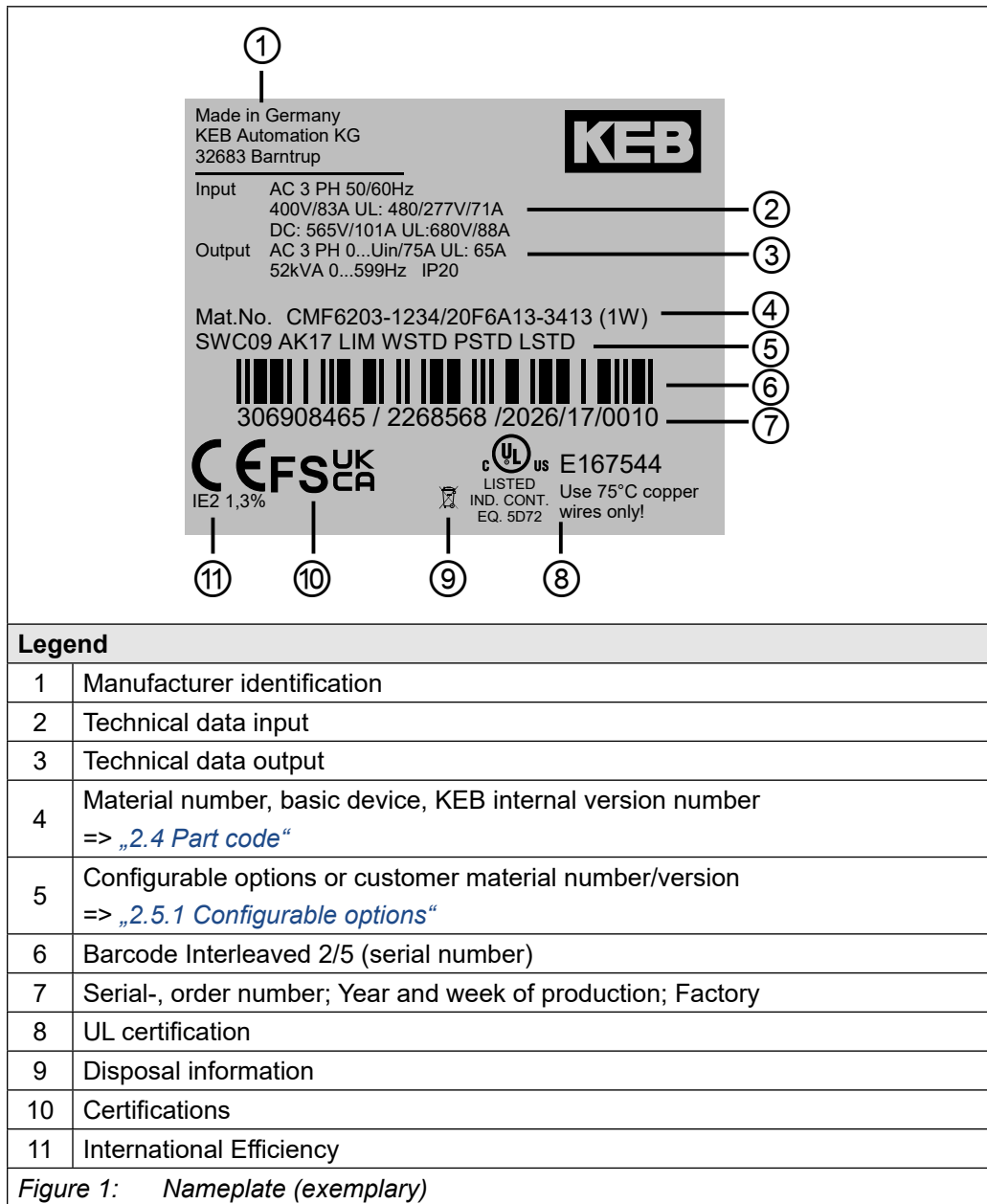

2.5.1 Configurable options

| Features | Feature values | Description |
|---------------------------------------|---------------------|---|
| Software | SWxxx ¹⁾ | Software status of the drive controller |
| Accessories | Axxx ¹⁾ | Selected accessories |
| | NAK | No accessories |
| Output frequency activation | LIM | Limitation to 599 Hz |
| | ULO | > 599 Hz activated |
| Warranty | WSTD | Warranty - Standard |
| | Wxxx ¹⁾ | Warranty extension |
| Parameterization | PSTD | Parameterization - Standard |
| | Pxxx ¹⁾ | Parameterization - Customer-specific |
| Nameplate logo | LSTD | Logo - Standard |
| | Lxxx ¹⁾ | Logo - Customer-specific |
| <i>Figure 2: Configurable options</i> | | |

¹⁾ „x“ indicates a variable value

3 Technical data

Unless otherwise indicated, all electrical data in the following chapter refer to a 3-phase AC mains.

3.1 Operating conditions

3.1.1 Climatic environmental conditions

| Storage | | Standard | Class | Descriptions |
|----------------------------------|-----|--------------|-------|---|
| Ambient temperature | | EN 60721-3-1 | 1K4 | -25...55 °C |
| Relative humidity | | EN 60721-3-1 | 1K3 | 5...95 % (without condensation) |
| Storage height | | – | – | Max. 3000 m above sea level |
| Transport | | Standard | Class | Descriptions |
| Ambient temperature | | EN 60721-3-2 | 2K3 | -25...70 °C |
| Relative humidity | | EN 60721-3-2 | 2K3 | 95 % at 40 °C (without condensation) |
| Operation | | Standard | Class | Descriptions |
| Ambient temperature | | EN 60721-3-3 | 3K3 | 5...40 °C (extended to -10...45 °C) |
| Coolant inlet temperature | Air | – | – | 5...40 °C (extended to -10...45 °C) |
| Relative humidity | | EN 60721-3-3 | 3K3 | 5...85 % (without condensation) |
| Version and degree of protection | | EN 60529 | IP20 | Protection against foreign material > ø12.5 mm No protection against water Non-conductive pollution, occasional condensation when PDS is out of service. Drive controller generally, except power connections and fan unit (IPxxA) |
| Site altitude | | – | – | Max. 2000 m above sea level <ul style="list-style-type: none"> • With site altitudes over 1000 m a derating of 1 % per 100 m must be taken into consideration. • With site altitudes over 2000 m, the control board to the mains has only basic isolation. Additional measures must be taken when wiring the control. |

Table 2: Climatic environmental conditions

3.1.2 Mechanical environmental conditions

| Storage | Standard | Class | Descriptions |
|--------------------|------------------------------|-------|---|
| Vibration limits | EN 60721-3-1 | 1M2 | Vibration amplitude 1.5 mm (2...9 Hz) Acceleration amplitude 5 m/s ² (9...200 Hz) |
| Shock limit values | EN 60721-3-1 | 1M2 | 40 m/s ² ; 22 ms |
| Transport | Standard | Class | Descriptions |
| Vibration limits | EN 60721-3-2 | 2M1 | Vibration amplitude 3.5 mm (2...9 Hz) Acceleration amplitude 10 m/s ² (9...200 Hz) |
| Shock limit values | EN 60721-3-2 | 2M1 | 100 m/s ² ; 11 ms |
| Operation | Standard | Class | Descriptions |
| Vibration limits | EN 60721-3-3 | 3M4 | Vibration amplitude 3.0 mm (2...9 Hz) Acceleration amplitude 10 m/s ² (9...200 Hz) |
| | EN 61800-5-1 | – | Vibration amplitude 0.075 mm (10...58 Hz) Acceleration amplitude 10 m/s ² (58...150 Hz) |
| Shock limit values | EN 60721-3-3 | 3M4 | 100 m/s ² ; 11 ms |

Table 3: Mechanical environmental conditions

3.1.3 Further environmental operating conditions

| Operation | Standard | Class | Descriptions |
|--------------------------------|------------------------------|-------|----------------|
| Chemically active substances | EN 60721-3-3 | 3C2 | No salt spray |
| Mechanically active substances | | 3S2 | – |
| Organic | | 3B1 | – |
| UV resistance | EN 61800-5-1 | – | No requirement |

Table 4: Further environmental operating conditions

3.1.4 Electrical operating conditions

3.1.4.1 Device classification

| Requirement | Standard | Class | Descriptions |
|----------------------|------------------------------|-------|--|
| Overtoltage category | EN 61800-5-1 | III | – |
| Pollution degree | EN 61800-5-1 | 2 | Non-conductive pollution, occasional condensation when PDS is out of service |

Table 5: Device classification

3.1.4.2 Electromagnetic compatibility

For devices without an internal filter, an external filter is required to comply with the following limits.

| EMC emitted interference | Standard | Class | Descriptions |
|---|--|--------------------------|---|
| Conducted interference emission | EN 61800-3 | C2 / C3 | The specified value is only maintained in connection with a filter. Information about interference suppression (rated switching frequency, max. motor cable length) can be found in the corresponding filter instructions.. |
| Radiated emitted interference | EN 61800-3 | C2 | – |
| EMF | EN 61800-5-1 | – | Table P.2 |
| Immunity | Standard | Level | Descriptions |
| Static discharges | EN 61000-4-2 | 8 kV 4 kV | AD (air discharge) CD (contact discharge) |
| Burst - Ports for process measurement control lines and signal interfaces | EN 61000-4-4 | 2 kV | – |
| Burst - AC - power ports | EN 61000-4-4 | 4 kV | – |
| Surge - Power ports | EN 61000-4-5 | 1 kV 2 kV | Phase-phase Phase-ground |
| Conducted immunity, induced by high-frequency fields | EN 61000-4-6 | 10 V | 0.15...80 MHz |
| Electromagnetic fields | EN 61000-4-3 | 10 V/m 3 V/m 1 V/m | 80 MHz...1 GHz 1.4...2 GHz 2...2.7 GHz |
| voltage dips | EN 61000-4-11 EN 61000-4-34 | Class 3 | – |
| frequency fluctuations | EN 61000-4-28 | ± 2 % | – |
| Voltage unbalances | EN 61000-2-4 | ≤ 3 % | – |

Table 6: Electromagnetic compatibility

3.2 Device data of the 230 V peak power devices

3.2.1 Overview of 230 V peak power devices

The technical data are for 2/4-pole standard motors. With other pole numbers the drive controller must be dimensioned onto the rated motor current. Contact KEB for special or medium frequency motors.

| Device size | | 16 | 17 |
|--|----------------------------------|--|-----------|
| Housing | | 4 | |
| Rated apparent output power | S_{out} / kVA | 24 | 30 |
| Max. rated motor power | ¹⁾ P_{mot} / kW | 15 | 18,5 |
| Rated input voltage | U_N / V | 230 (UL: 240) | |
| Input voltage range | U_{in} / V | 170...264 | |
| Mains phases | | 3 | |
| Mains frequency | f_N / Hz | 50 / 60 ±2 | |
| Rated input current @ $U_N = 230$ V | I_{in} / A | 68 | 82 |
| Rated input current @ $U_N = 240$ V | I_{in_UL} / A | 68 | 82 |
| Insulation resistance @ $U_{dc} = 500$ V | R_{iso} / MΩ | > 20 | |
| Leakage current | I_{iso_ac} / mA | > 3.5 | |
| Output voltage | U_{out} / V | 0... U_{in} | |
| Output frequency | ²⁾ f_{out} / Hz | 0...599 | |
| Output phases | | 3 | |
| Rated output current @ $U_N = 230$ V | I_N / A | 62 | 75 |
| Rated output current @ $U_N = 240$ V | I_{N_UL} / A | 62 | 75 |
| Rated output overload (60s) | ^{3) 4)} I_{60s} / % | 200 | 200 |
| Software current limit | ^{3) 9)} I_{lim} / % | 216 | 225 |
| Overcurrent | ³⁾ I_{OC} / % | 260 | 270 |
| Rated switching frequency | f_{SN} / kHz | 8 | 8 |
| Max. switching frequency | ⁵⁾ f_{S_max} / kHz | 16 | 16 |
| Power dissipation at rated operation | ¹⁾ P_D / W | 678 | 906 |
| Overload current over time | ³⁾ I_{OL} / % | => „3.2.3.1 Overload characteristic (OL) for 230 V peak power devices“ | |
| Maximum current 0Hz/50Hz at $f_s = 2$ kHz | I_{out_max} / % | 203 / 260 | 198 / 270 |
| Maximum current 0Hz/50Hz at $f_s = 4$ kHz | I_{out_max} / % | 172 / 260 | 166 / 270 |
| Maximum current 0Hz/50Hz at $f_s = 8$ kHz | I_{out_max} / % | 133 / 225 | 125 / 213 |
| Maximum current 0Hz/50Hz at $f_s = 16$ kHz | I_{out_max} / % | 88 / 158 | 82 / 145 |
| Max. braking current | I_{B_max} / A | 93 | 105 |
| Min. braking resistor value | R_{B_min} / Ω | 4,5 | 4 |

continued on the next page

DEVICE DATA OF THE 230 V PEAK POWER DEVICES

| Device size | 16 | 17 |
|---|---|-----|
| Housing | 4 | |
| Braking transistor ⁶⁾ | Max. cycle time: 120 s; Max c.d.f.: 50 % | |
| Protective function for braking transistor | Short-circuit monitoring | |
| Protective function braking resistor (Error GTR7 always on) ⁷⁾ | Feedback signal evaluation and current switch-off | |
| Max. motor cable length shielded ⁸⁾ / / m | 100 | 100 |

Table 7: Overview of the 230V Peak Power device data

- ¹⁾ Rated operation corresponds to $U_N = 230V$, rated switching frequency, output frequency = 50 Hz (4-pole standard asynchronous motor).
- ²⁾ The output frequency is to be limited in such a way that it does not exceed 1/10 of the switching frequency. Devices with higher maximum output frequencies are subject to export restrictions and are only available on request.
- ³⁾ The values refer in % to the rated output current I_N .
- ⁴⁾ Observe limitations => „3.2.3.1 Overload characteristic (OL) for 230 V peak power devices“.
- ⁵⁾ A precise description of the derating => „3.4.1 Switching frequency and temperature“.
- ⁶⁾ The cyclic duration factor is additionally limited by the used braking resistor. Values apply to external braking resistors.
- ⁷⁾ The feedback signal evaluation monitors the functionality of the braking transistor. The power is switched off via the internal mains input bridge of the AC supply.
- ⁸⁾ The maximum cable length depends on various factors. Further information can be found in the corresponding filter instructions.
- ⁹⁾ In overload operation, the mains choke can become saturated, which can lead to reduction in service life.

3.2.2 Voltage and frequencies for 230V devices

| Input voltages and frequencies | | |
|--------------------------------|-----------------|-----------|
| Rated input voltage | U_N / V | 230 |
| Rated mains voltage (USA) | U_{N_UL} / V | 240 |
| Input voltage range | U_{IN} / V | 170...264 |
| Input phases | | 3 |
| Mains frequency | f_N / Hz | 50/60 |
| Mains frequency tolerance | $\pm f_N / Hz$ | 2 |

Table 8: Input voltages and frequencies of the 230V devices

| DC link voltage | | |
|--|---------------------|-----------|
| DC link rated voltage @ $U_N = 400V$ | U_{N_dc} / V | 325 |
| DC link rated voltage @ $U_{N_UL} = 480V$ | $U_{N_UL_dc} / V$ | 339 |
| DC link voltage working voltage range | U_{IN_dc} / V | 240...373 |

Table 9: DC link voltage for 230V devices

| Output voltages and frequencies | | |
|---------------------------------|------------------------------|---------------|
| Output voltage at AC supply | ¹⁾ U_{out} / V | 0... U_{in} |
| Output frequency | ²⁾ f_{out} / Hz | 0...599 |
| Output phase | | 3 |

Table 10: Output voltages and frequencies of the 230V devices

- ¹⁾ The voltage to the motor is dependent on the actual input voltage and the control method („3.2.2.1 Example of the calculation of the possible motor voltage 230V“).
- ²⁾ The output frequency is to be limited in such a way that it does not exceed 1/10 of the switching frequency. Devices with a maximum output frequency higher than 599Hz are restricted for export.

3.2.2.1 Example of the calculation of the possible motor voltage 230V

The motor voltage for dimensioning of the drive is depending on the used components. The motor voltage reduces according to the following table.

| Component | Reduction / % | Example |
|------------------------------|---------------|--|
| Mains choke U_k | 4 | Example: Open-loop drive controller with mains- and motor choke at non-rigid supply system: 230 V mains voltage - 11 % = 204,7 V motor voltage |
| Drive controller open-loop | 4 | |
| Drive controller closed-loop | 8 | |
| Motor choke U_k | 1 | |
| Non-rigid supply system | 2 | |

Table 11: Example of the calculation of the possible motor voltage 230V

3.2.3 Input and output currents/overload for 230 V peak power devices

| Device size | | 16 | 17 |
|--|---------------------------------|--|-----|
| Rated input current @ $U_N = 230 V$ | ¹⁾ I_{in} / A | 68 | 82 |
| Rated input current @ $U_{N_UL} = 240 V$ | ¹⁾ I_{in_UL} / A | 68 | 82 |
| Rated output current @ $U_N = 230 V$ | I_N / A | 62 | 75 |
| Rated output current @ $U_{N_UL} = 240 V$ | I_{N_UL} / A | 62 | 75 |
| Rated output overload (60 s) | ²⁾ $I_{60s} / \%$ | 200 | 200 |
| Overload current | ²⁾ $I_{OL} / \%$ | => „3.2.3.1 Overload characteristic (OL) for 230 V peak power devices“ | |
| Software current limit | ^{2) 3)} $I_{lim} / \%$ | 216 | 225 |
| Overcurrent | ²⁾ $I_{oc} / \%$ | 260 | 270 |

Table 12: Input and output currents of the 230 V peak power devices

- ¹⁾ The values resulting from rated operation with B6 rectifier circuit and mains choke 4% U_k .
- ²⁾ The values refer in % to the rated output current I_N .
- ³⁾ Limitation of the current setpoint in closed-loop operation. This setpoint limit is not active in v/f operation.

3.2.3.1 Overload characteristic (OL) for 230 V peak power devices

All drive controllers can be operated at rated switching frequency with an utilisation of 200 % for 60s.

The OL overload function is a root mean square (RMS) function.

The greater the difference between the overload and underload phases, the greater the deviation of the RMS from the arithmetic mean value.

For extreme overloads (=> „Figure 3: Switch-off time t depending on the overload I/I_N at OC level 260 % (OL)“ / „Figure 4: Switch-off time t depending on the overload I/I_N at OC level 270 % (OL)“ the load is weighted more heavily. This means the load is provided with a factor for the calculation of the RMS value, by way that the overload protection function triggers, even if the RMS value does not reach 100%.

Restrictions:

- The thermal design of the heat sink is based on the rated operation. The following values are taken into account: Rated output current, ambient temperature, rated switching frequency, rated voltage.
- At high ambient temperatures and/or high heat sink temperatures (for example, by preceding utilisation nearby 100%) the drive controller can change to overtemperature error before triggering the protective function OL.
- At low output frequencies or switching frequencies higher than the rated switching frequency, the frequency-dependent maximum current can be exceeded before triggering the overload error OL and error OL2 can be triggered
=> „3.2.3.2 Frequency-dependent maximum current (OL2) for 230 V Peak Power devices“.

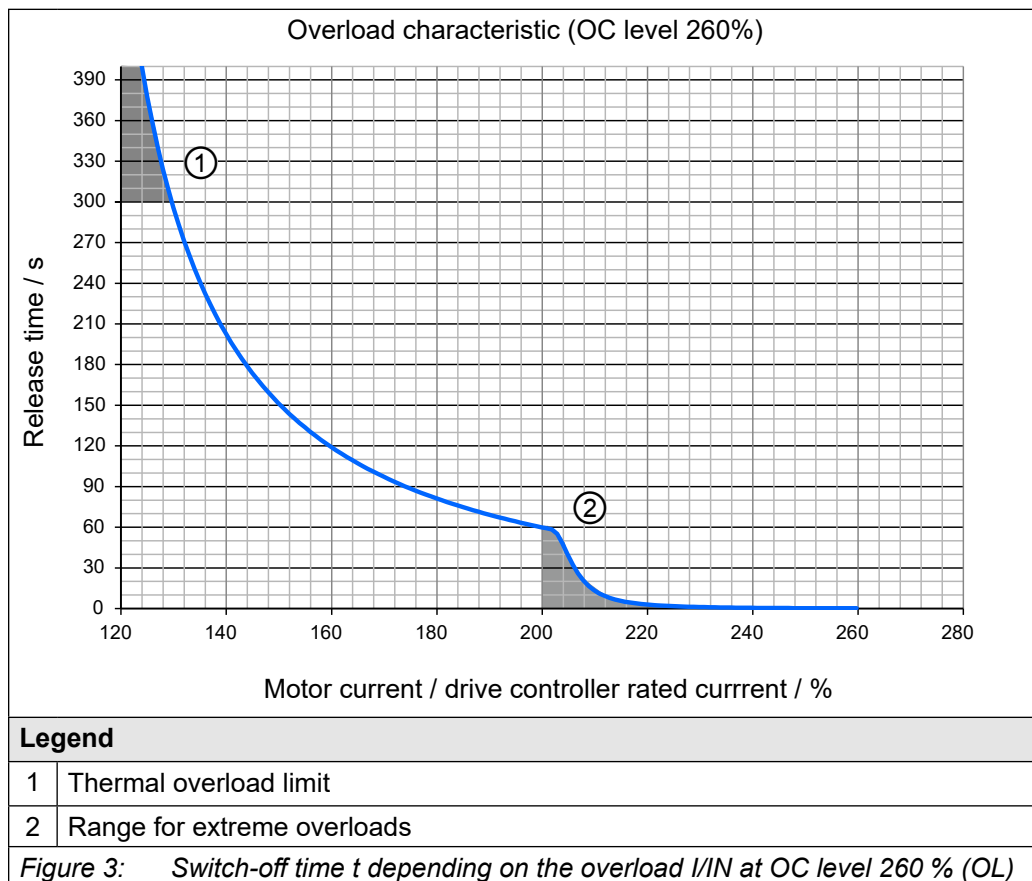

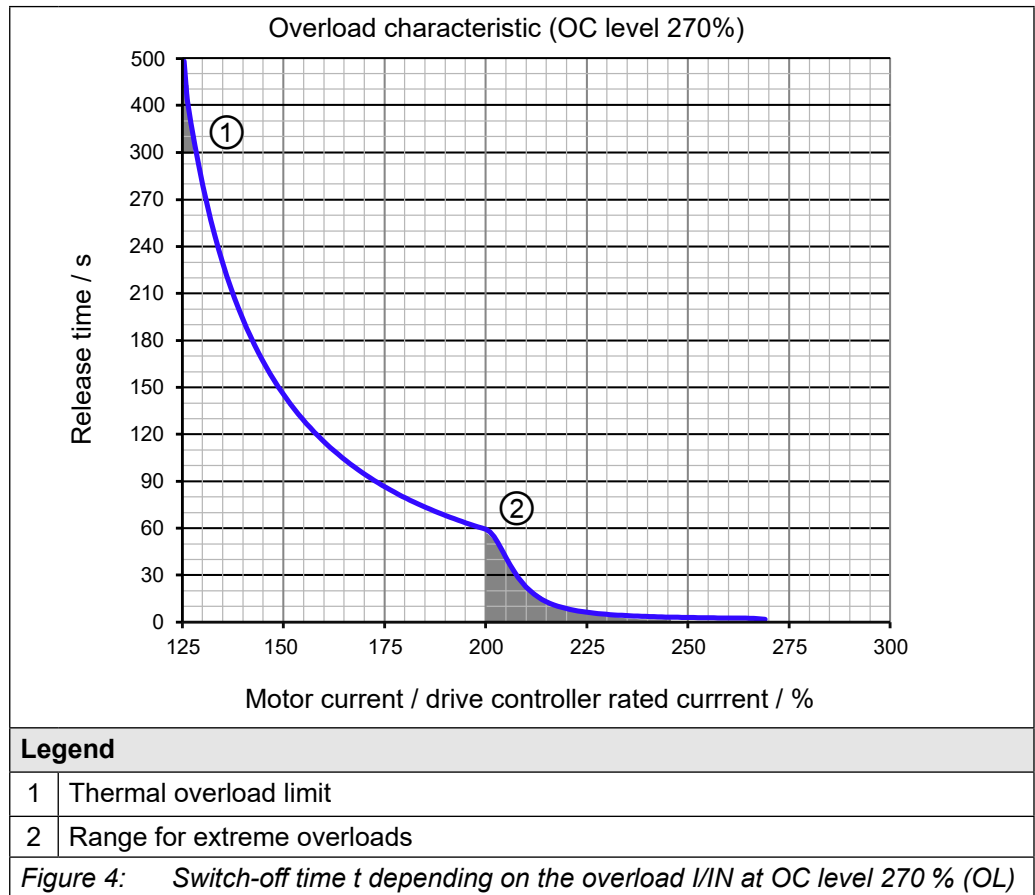

- On exceeding a load of 105 % the overload integrator starts.
- When falling below the integrator counts backwards.
- If the integrator reaches the overload characteristic "Error! overload (OL)" is triggered.

After a cooling down period, the integrator can be reset now. The drive controller must remain switched on during the cooling down phase.

Operation in the range of the thermal overload limit

Due to the high steepness of the overload characteristic, the duration of a permissible overload in this range ① cannot be determined exactly. Therefore, the design of the drive controller should be assumed to have a maximum overload time of 300s.

3.2.3.2 Frequency-dependent maximum current (OL2) for 230 V Peak Power devices

The characteristics of the maximum currents for a switching frequency which are depending on the output frequency are different for each drive controller, but the following rules are generally applicable:

- Applies for the rated switching frequency: at 0 Hz output frequency the drive controller can provide at least the rated output current.
- Lower maximum currents apply for switching frequencies > rated switching frequency.

If error (OL2) shall be triggered on exceeding the maximum currents or if the switching frequency is automatically reduced (derating) can be adjusted in the drive controller parameters.

The following characteristics indicate the permissible maximum current for the output frequency values 0 Hz, 3 Hz, 6 Hz, 10 Hz, 25 Hz and 50 Hz. Device size 16 is represented exemplary.

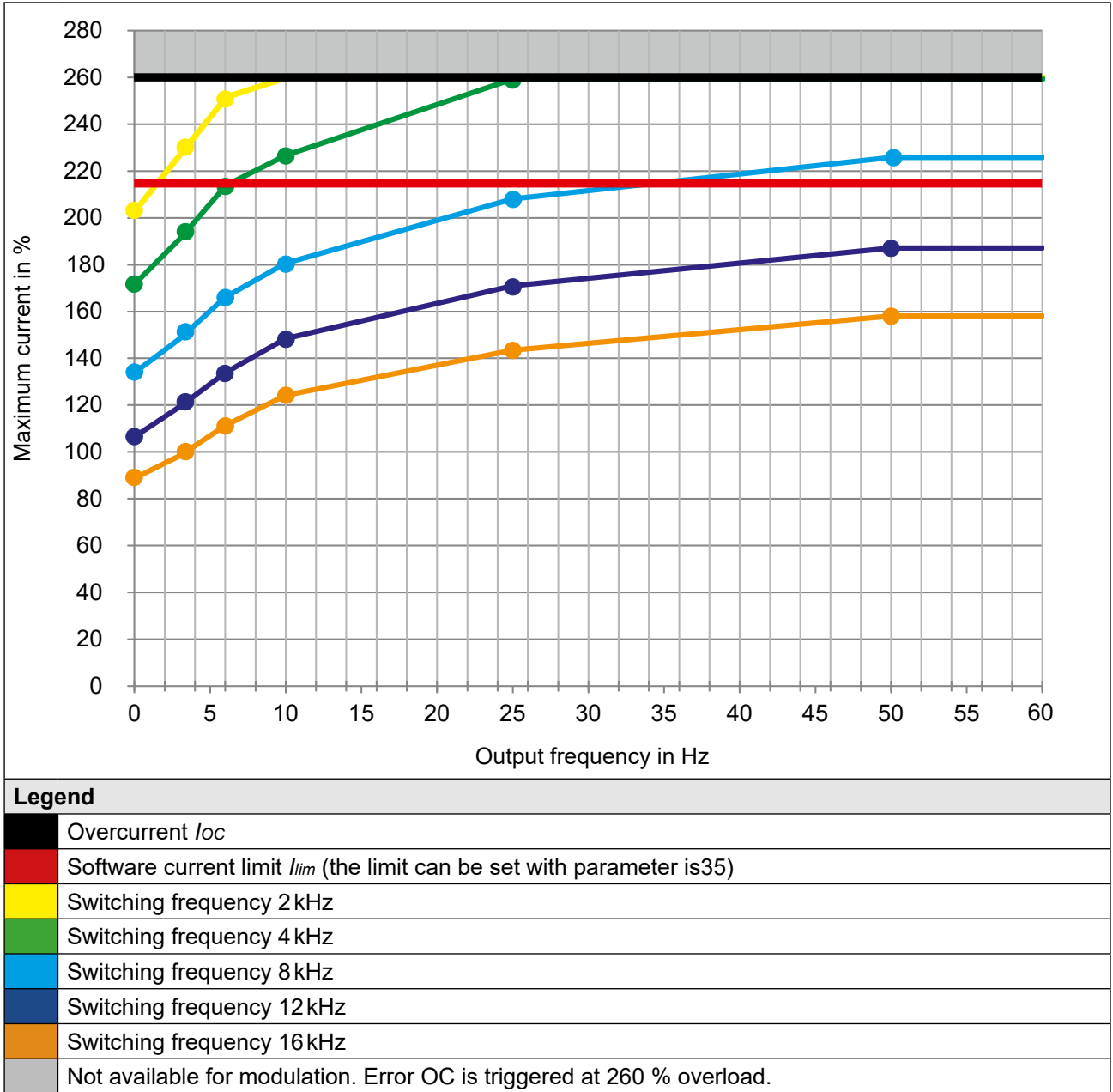

Figure 5: Typical overload characteristics in the lower output frequencies (OL2) example device size 16



The frequency-dependent maximum current I_{out_max} refers in % to the rated output current I_N .

The current remains constant from the last specified output frequency value.



The values for the respective device size are listed in the following tables.

Frequency-dependent maximum current

| Device size | 16 | | | | | | |
|---|-----------------------------|-----|-----|-----|-----|-----|-----|
| Rated switching frequency | 8 | | | | | | |
| Output frequency | <i>f_{out}</i> / Hz | 0 | 3 | 6 | 10 | 25 | 50 |
| Frequency-dependent maximum current @ <i>f_s</i> <i>I_{out_max}</i> / % <i>Basic Time Period = 62.5 μs (Parameter is22=0)</i> | 2 kHz | 203 | 227 | 251 | 260 | 260 | 260 |
| | 4 kHz | 172 | 191 | 214 | 233 | 260 | 260 |
| | 8 kHz | 133 | 148 | 166 | 180 | 208 | 225 |
| | 16 kHz | 88 | 98 | 111 | 124 | 143 | 158 |
| Frequency-dependent maximum current @ <i>f_s</i> <i>I_{out_max}</i> / % <i>Basic Time Period = 71.4 μs (Parameter is22=1)</i> | 1.75 kHz | 203 | 227 | 251 | 260 | 260 | 260 |
| | 3.5 kHz | 180 | 200 | 223 | 243 | 260 | 260 |
| | 7 kHz | 143 | 159 | 178 | 194 | 222 | 241 |
| | 14 kHz | 97 | 108 | 122 | 136 | 157 | 172 |
| Frequency-dependent maximum current @ <i>f_s</i> <i>I_{out_max}</i> / % <i>Basic Time Period = 83.3 μs (Parameter is22=2)</i> | 1.5 kHz | 203 | 227 | 251 | 260 | 260 | 260 |
| | 3 kHz | 187 | 209 | 233 | 253 | 260 | 260 |
| | 6 kHz | 153 | 170 | 190 | 207 | 236 | 256 |
| | 12 kHz | 106 | 119 | 133 | 148 | 171 | 187 |
| Frequency-dependent maximum current @ <i>f_s</i> <i>I_{out_max}</i> / % <i>Basic Time Period = 100 μs (Parameter is22=3)</i> | 1.25 kHz | 203 | 227 | 251 | 260 | 260 | 260 |
| | 2.5 kHz | 195 | 218 | 242 | 260 | 260 | 260 |
| | 5 kHz | 162 | 181 | 202 | 220 | 250 | 260 |
| | 10 kHz | 120 | 133 | 150 | 164 | 189 | 206 |

Table 13: Frequency-dependent maximum current for device size 16 peak power

| Device size | | 17 | | | | | |
|--|-----------------------|-----|-----|-----|-----|-----|-----|
| Rated switching frequency | | 8 | | | | | |
| Output frequency | f_{out} / Hz | 0 | 3 | 6 | 10 | 25 | 50 |
| Frequency-dependent maximum current @ f_s <i>Basic Time Period = 62.5 μs (Parameter is22=0)</i> | 2 kHz | 198 | 221 | 245 | 266 | 270 | 270 |
| | 4 kHz | 166 | 184 | 205 | 224 | 254 | 270 |
| | 8 kHz | 125 | 140 | 156 | 170 | 196 | 213 |
| | 16 kHz | 82 | 90 | 102 | 113 | 132 | 145 |
| Frequency-dependent maximum current @ f_s <i>Basic Time Period = 71.4 μs (Parameter is22=1)</i> | 1.75 kHz | 198 | 221 | 245 | 266 | 270 | 270 |
| | 3.5 kHz | 174 | 193 | 215 | 234 | 266 | 270 |
| | 7 kHz | 135 | 151 | 168 | 184 | 210 | 228 |
| | 14 kHz | 90 | 100 | 113 | 125 | 145 | 159 |
| Frequency-dependent maximum current @ f_s <i>Basic Time Period = 83.3 μs (Parameter is22=2)</i> | 1.5 kHz | 198 | 221 | 245 | 266 | 270 | 270 |
| | 3 kHz | 182 | 202 | 225 | 245 | 270 | 270 |
| | 6 kHz | 146 | 162 | 180 | 197 | 225 | 244 |
| | 12 kHz | 98 | 109 | 124 | 137 | 158 | 173 |
| Frequency-dependent maximum current @ f_s <i>Basic Time Period = 100 μs (Parameter is22=3)</i> | 1.25 kHz | 198 | 221 | 245 | 266 | 270 | 270 |
| | 2.5 kHz | 190 | 212 | 235 | 256 | 270 | 270 |
| | 5 kHz | 156 | 173 | 193 | 210 | 240 | 259 |
| | 10 kHz | 112 | 124 | 140 | 154 | 177 | 193 |

Table 14: Frequency-dependent maximum current for device size 17 peak power

3.2.4 Power dissipation at rated operation of the 230 V peak power devices

| Device size | 16 | 17 |
|--|-----|-----|
| Power dissipation at rated operation ¹⁾ P_D / W | 678 | 906 |

Table 15: Power dissipation of the 230 V peak power devices

¹⁾ Rated operation corresponds to $U_N = 230\text{ V}$; f_{SN} ; I_N ; $f_N = 50\text{ Hz}$ (typically value)

3.2.5 Fusing for 230 V peak power devices

| Device size | Max. size of the fuse / A | | | | |
|-------------|----------------------------------|-----------------------------------|----------------------|--------------------------|--------|
| | $U_N = 230\text{ V}$ gG (IEC) | $U_N = 240\text{ V}$ Class "J" | $U_N = 240\text{ V}$ | | |
| | SCCR 30 kA | SCCR 5 kA | SCCR 30 kA | Type | Rating |
| 16 | 80 | 100 | 100 | SIBA 20 1xy 20.100 | 700Vac |
| | | | 100 | COOPER BUSSMANN 170M1367 | 700Vac |
| 17 | 125 | 125 | 125 | SIBA 20 1xy 20.125 | 700Vac |
| | | | 125 | COOPER BUSSMANN 170M1368 | 700Vac |

Table 16: Fusings for 230 V peak power devices

¹⁾ "x" stands for various indicators. "y" stands for various connection variants.



Short-circuit capacity

According to requirements from [EN 61439-1](#) and [EN 61800-5-1](#), the following applies to connection to a mains supply: The devices are suitable for use in a circuit capable of delivering not more than 30 kA eff. unaffected symmetrical short-circuit current.

3.3 Device data of the 400 V peak power devices

3.3.1 Overview of 400 V peak power devices

The technical data are for 2/4-pole standard motors. With other pole numbers the drive controller must be dimensioned onto the rated motor current. Contact KEB for special or medium frequency motors.

| Device size | | 18 | 19 |
|--|----------------------------------|--|---|
| Housing | | 4 | |
| Rated apparent output power | S_{out} / kVA | 35 | 42 |
| Max. rated motor power | ¹⁾ P_{mot} / kW | 22 | 30 |
| Rated input voltage | U_N / V | 400 (UL: 480) | |
| Input voltage range | U_{in} / V | 280...550 | |
| Mains phases | | 3 | |
| Mains frequency | f_N / Hz | 50 / 60 ±2 | |
| Rated input current @ $U_N = 400$ V | I_{in} / A | 59 | 66 |
| Rated input current @ $U_N = 480$ V | I_{in_UL} / A | 48 | 59 |
| Insulation resistance @ $U_{dc} = 500$ V | R_{iso} / MΩ | > 20 | |
| Leakage current | I_{iso_ac} / mA | > 3.5 | > 3.5 |
| Output voltage | U_{out} / V | 0... U_{in} | |
| Output frequency | ²⁾ f_{out} / Hz | 0...599 | |
| Output phases | | 3 | |
| Rated output current @ $U_N = 400$ V | I_N / A | 50 | 60 |
| Rated output current @ $U_N = 480$ V | I_{N_UL} / A | 40 | 54 |
| Rated output overload (60s) | ³⁾⁴⁾ I_{60s} / % | 160 | 200 |
| Software current limit | ³⁾¹¹⁾ I_{lim} / % | 200 | 225 |
| Overcurrent | ³⁾ I_{OC} / % | 240 | 270 |
| Rated switching frequency | f_{SN} / kHz | 4 (S1 operation), 8 (S3 operation) ⁹⁾ | 4 (S1 operation), 8 (S3 operation) ¹⁰⁾ |
| Max. switching frequency | ⁵⁾ f_{S_max} / kHz | 16 | 16 |
| Power dissipation at rated operation | ¹⁾ P_D / W | 558 | 698 |
| Overload current over time | ³⁾ I_{OL} / % | => „3.3.3.1 Overload characteristic (OL) for 400 V peak power devices“ | |
| Maximum current 0Hz/50Hz at $f_s = 2$ kHz | I_{out_max} / % | 212 / 240 | 205 / 270 |
| Maximum current 0Hz/50Hz at $f_s = 4$ kHz | I_{out_max} / % | 162 / 240 | 152 / 253 |
| Maximum current 0Hz/50Hz at $f_s = 8$ kHz | I_{out_max} / % | 106 / 188 | 95 / 172 |
| Maximum current 0Hz/50Hz at $f_s = 16$ kHz | I_{out_max} / % | 56 / 104 | 45 / 87 |

continued on the next page

DEVICE DATA OF THE 400 V PEAK POWER DEVICES

| Device size | | 18 | 19 |
|--|-----------------------|--|----|
| Housing | | 4 | |
| Max. braking current | I_{B_max} / A | 93 | 93 |
| Min. braking resistor value | R_{B_min} / Ω | 9 | 8 |
| Braking transistor | ⁶⁾ | Max. cycle time: 120 s; Max c.d.f.: 50 % | |
| Protective function for braking transistor | | Short-circuit monitoring | |
| Protective function braking resistor (Error GTR7 always on) | ⁷⁾ | Feedback signal evaluation and current switch-off (only for AC mains connection) | |
| Max. motor cable length shielded | ⁸⁾ l / m | 50 | 50 |

Table 17: Overview of the 400V Peak Power device data

- ¹⁾ Rated operation corresponds to $U_N = 400V$, rated switching frequency, output frequency = 50 Hz (4-pole standard asynchronous motor).
- ²⁾ The output frequency is to be limited in such a way that it does not exceed 1/10 of the switching frequency. Devices with higher maximum output frequencies are subject to export restrictions and are only available on request.
- ³⁾ The values refer in % to the rated output current I_N .
- ⁴⁾ Observe limitations => „3.3.3.1 Overload characteristic (OL) for 400 V peak power devices“.
- ⁵⁾ A precise description of the derating => „3.4.1 Switching frequency and temperature“.
- ⁶⁾ The cyclic duration factor is additionally limited by the used braking resistor. Values apply to external braking resistors.
- ⁷⁾ The feedback signal evaluation monitors the functionality of the braking transistor. The power is switched off via the internal mains input bridge of the AC supply. There is no current switch-off with DC supply.
- ⁸⁾ The maximum cable length depends on various factors. Further information can be found in the corresponding filter instructions.
- ⁹⁾ ED: 70%, T_p : 35s
- ¹⁰⁾ ED: 70%, T_p : 10s
- ¹¹⁾ In overload operation, the mains choke can become saturated, which can lead to reduction in service life.

3.3.2 Voltage and frequencies for 400V devices

| Input voltages and frequencies | | |
|--------------------------------|-----------------|-----------|
| Rated input voltage | U_N / V | 400 |
| Rated mains voltage (USA) | U_{N_UL} / V | 480 |
| Input voltage range | U_{IN} / V | 280...550 |
| Input phases | | 3 |
| Mains frequency | f_N / Hz | 50/60 |
| Mains frequency tolerance | $\pm f_N / Hz$ | 2 |

Table 18: Input voltages and frequencies of the 400V devices

| DC link voltage | | |
|--|---------------------|-----------|
| DC link rated voltage @ $U_N = 400V$ | U_{N_dc} / V | 565 |
| DC link rated voltage @ $U_{N_UL} = 480V$ | $U_{N_UL_dc} / V$ | 680 |
| DC link voltage working voltage range | U_{IN_dc} / V | 390...780 |

Table 19: DC link voltage for 400V devices

| Output voltages and frequencies | | |
|---------------------------------|------------------------------|------------------|
| Output voltage at AC supply | ¹⁾ U_{out} / V | 0... U_{N_ac} |
| Output frequency | ²⁾ f_{out} / Hz | 0...599 |
| Output phase | | 3 |

Table 20: Output voltages and frequencies of the 400V devices

- ¹⁾ The voltage to the motor is dependent on the actual input voltage and the control method => („3.3.2.1 Example of the calculation of the possible motor voltage:“).
- ²⁾ The output frequency is to be limited in such a way that it does not exceed 1/10 of the switching frequency. Devices with a maximum output frequency higher than 599Hz are restricted for export.

3.3.2.1 Example of the calculation of the possible motor voltage:

The motor voltage for dimensioning of the drive is depending on the used components. The motor voltage reduces according to the following table:

| Component | Reduction / % | Example |
|------------------------------|---------------|---|
| Mains choke U_k | 4 | Open-loop drive controller with mains- and motor choke at non-rigid supply system: 400 V mains voltage (100%) - 36 V reduced voltage (11%) = 356 V motor voltage |
| Drive controller open-loop | 4 | |
| Drive controller closed-loop | 8 | |
| Motor choke U_k | 1 | |
| Non-rigid supply system | 2 | |

Table 21: Example of the calculation of the possible motor voltage:

3.3.3 Input and output currents/overload for 400 V peak power devices

| Device size | | 18 | 19 |
|---|---------------------------------|--|-----|
| Rated input current @ $U_N = 400V$ | ¹⁾ I_{in} / A | 59 | 66 |
| Rated input current @ $U_{N_UL} = 480V$ | ¹⁾ I_{in_UL} / A | 48 | 59 |
| Rated input current DC @ $U_{N_dc} = 565V$ | | 73 | 58 |
| Rated input current DC @ $U_{N_UL_dc} = 680V$ | | 81 | 73 |
| Rated output current @ $U_N = 400V$ | I_N / A | 50 | 60 |
| Rated output current @ $U_{N_UL} = 480V$ | I_{N_UL} / A | 40 | 54 |
| Rated output overload (60 s) | ²⁾ $I_{60s} / \%$ | 160 | 200 |
| Overload current | ²⁾ $I_{OL} / \%$ | => „3.3.3.1 Overload characteristic (OL) for 400 V peak power devices“ | |
| Software current limit | ^{2) 3)} $I_{lim} / \%$ | 200 | 225 |
| Overcurrent | ²⁾ $I_{oc} / \%$ | 240 | 270 |

Table 22: Input and output currents of the 400 V peak power devices

- ¹⁾ The values resulting from rated operation with B6 rectifier circuit and mains choke 4% U_k .
- ²⁾ The values refer in % to the rated output current I_N .
- ³⁾ Limitation of the current setpoint in closed-loop operation. This setpoint limit is not active in v/f operation.

3.3.3.1 Overload characteristic (OL) for 400 V peak power devices

All drive controllers can be operated at rated switching frequency with an utilisation of 160% or 200% for 60s.

The OL overload function is a root mean square (RMS) function.

The greater the difference between the overload and underload phases, the greater the deviation of the RMS from the arithmetic mean value.

For extreme overloads (=> „Figure 6: Switch-off time t depending on the overload I/I_N at OC level 240 % (OL)“ or „Figure 7: Switch-off time t depending on the overload I/I_N at OC level 270 % (OL)“) the load is weighted more heavily. This means the load is provided with a factor for the calculation of the RMS value, by way that the overload protection function triggers, even if the RMS value does not reach 100%.

Restrictions:

- The thermal design of the heat sink is based on the rated operation. The following values are taken into account: Rated output current, ambient temperature, rated switching frequency, rated voltage.
- At high ambient temperatures and/or high heat sink temperatures (for example, by preceding utilisation nearby 100%) the drive controller can change to overtemperature error before triggering the protective function OL.
- At low output frequencies or switching frequencies higher than the rated switching frequency, the frequency-dependent maximum current can be exceeded before and error OL2 can be triggered
=> „3.3.3.2 Frequency-dependent maximum current (OL2) for 400 V Peak Power devices“.

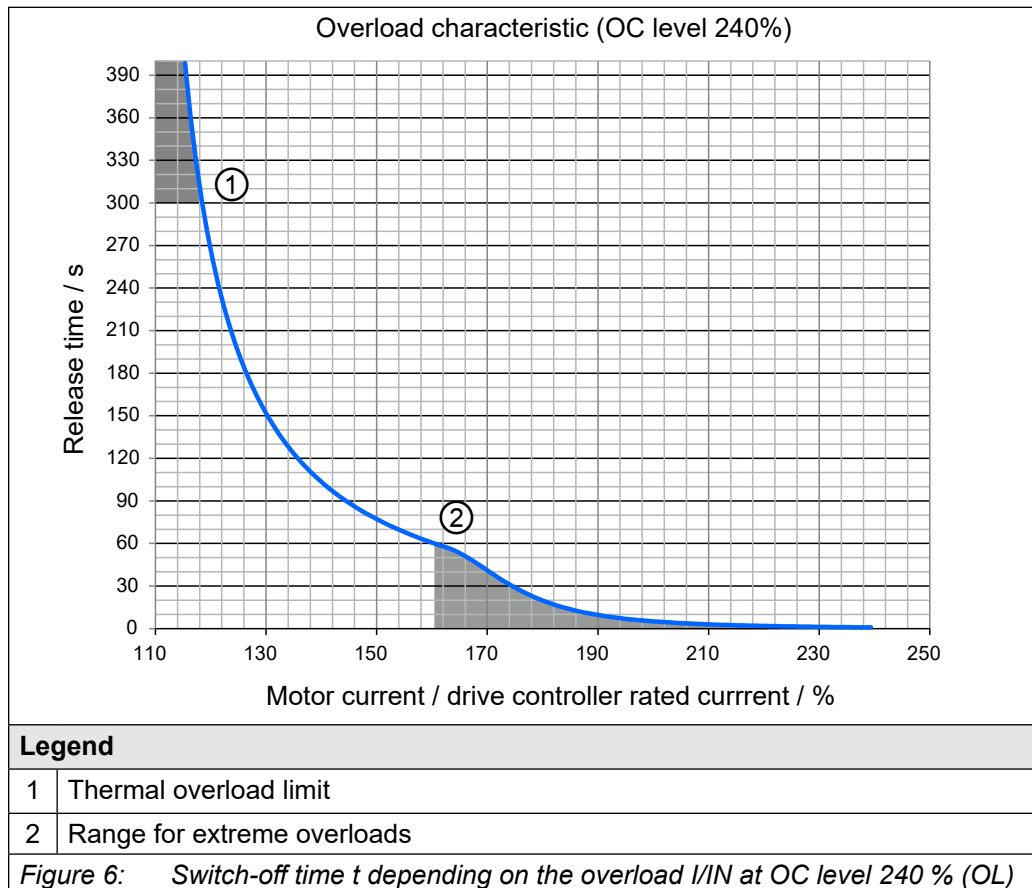

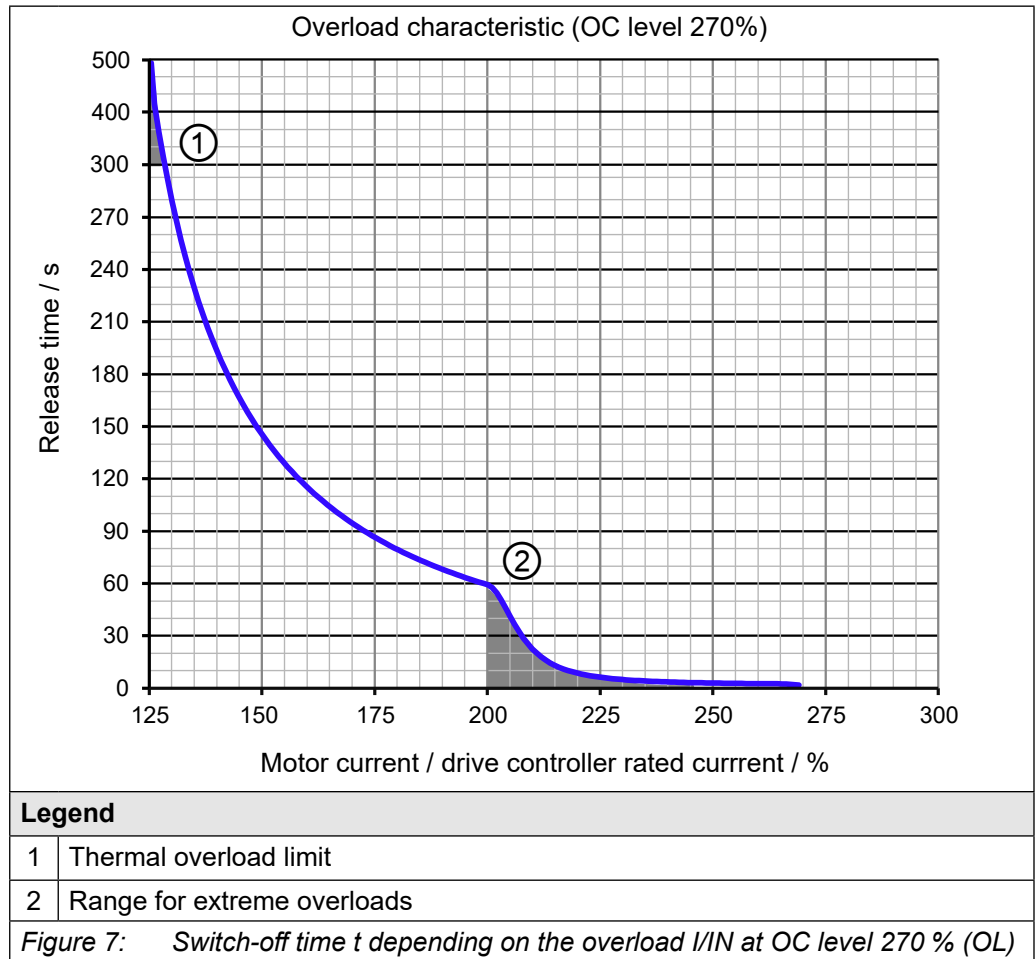

- On exceeding a load of 105 % the overload integrator starts.
- When falling below the integrator counts backwards.
- If the integrator reaches the overload characteristic "Error! overload (OL)" is triggered.

After a cooling down period, the integrator can be reset now. The drive controller must remain switched on during the cooling down phase.

Operation in the range of the thermal overload limit

Due to the high steepness of the overload characteristic, the duration of a permissible overload in this range ① cannot be determined exactly. Therefore, the design of the drive controller should be assumed to have a maximum overload time of 300 s.

3.3.3.2 Frequency-dependent maximum current (OL2) for 400 V Peak Power devices

The characteristics of the maximum currents for a switching frequency which are depending on the output frequency are different for each drive controller, but the following rules are generally applicable:

- Applies for the rated switching frequency: at 0 Hz output frequency the drive controller can provide at least the rated output current.
- Lower maximum currents apply for switching frequencies > rated switching frequency.

If error (OL2) shall be triggered on exceeding the maximum currents or if the switching frequency is automatically reduced (derating) can be adjusted in the drive controller parameters.

The following characteristics indicate the permissible maximum current for the output frequency values 0 Hz, 3 Hz, 6 Hz, 10 Hz, 25 Hz and 50 Hz. Device size 19 is represented exemplary.

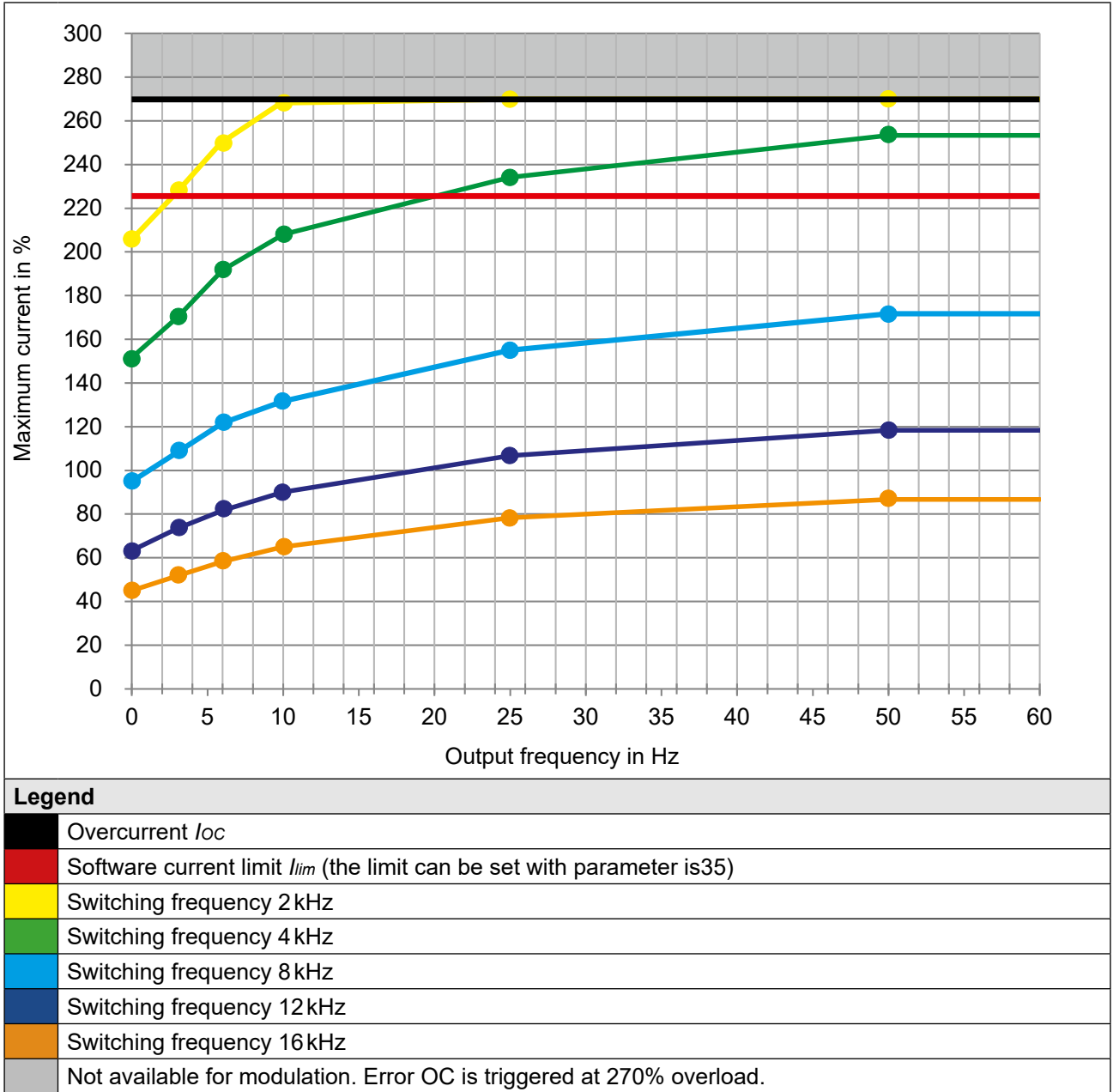

Figure 8: Typical overload characteristics in the lower output frequencies (OL2) example device size 19



The frequency-dependent maximum current I_{out_max} refers in % to the rated output current I_N .

The current remains constant from the last specified output frequency value.



The values for the respective device size are listed in the following tables.

Frequency-dependent maximum current

| Device size | | 18 | | | | | |
|---|-----------------------------|--|-----|-----|-----|-----|-----|
| Rated switching frequency | | 4 (S1 operation), 8 (S3 operation) ¹⁾ | | | | | |
| Output frequency | <i>f_{out}</i> / Hz | 0 | 3 | 6 | 10 | 25 | 50 |
| Frequency-dependent maximum current @ <i>f_s</i> <i>I_{out_max}</i> / % <i>Basic Time Period = 62.5 μs (Parameter is22=0)</i> | 2 kHz | 212 | 234 | 240 | 240 | 240 | 240 |
| | 4 kHz | 162 | 180 | 202 | 220 | 240 | 240 |
| | 8 kHz | 106 | 118 | 134 | 148 | 172 | 188 |
| | 16 kHz | 56 | 64 | 72 | 78 | 94 | 104 |
| Frequency-dependent maximum current @ <i>f_s</i> <i>I_{out_max}</i> / % <i>Basic Time Period = 71.4 μs (Parameter is22=1)</i> | 1.75 kHz | 212 | 234 | 240 | 240 | 240 | 240 |
| | 3.5 kHz | 175 | 194 | 217 | 237 | 240 | 240 |
| | 7 kHz | 120 | 134 | 151 | 166 | 192 | 210 |
| | 14 kHz | 66 | 75 | 84 | 92 | 110 | 121 |
| Frequency-dependent maximum current @ <i>f_s</i> <i>I_{out_max}</i> / % <i>Basic Time Period = 83.3 μs (Parameter is22=2)</i> | 1.5 kHz | 212 | 234 | 240 | 240 | 240 | 240 |
| | 3 kHz | 187 | 207 | 232 | 240 | 240 | 240 |
| | 6 kHz | 134 | 149 | 168 | 184 | 212 | 232 |
| | 12 kHz | 76 | 86 | 96 | 106 | 126 | 138 |
| Frequency-dependent maximum current @ <i>f_s</i> <i>I_{out_max}</i> / % <i>Basic Time Period = 100 μs (Parameter is22=3)</i> | 1.25 kHz | 212 | 234 | 240 | 240 | 240 | 240 |
| | 2.5 kHz | 200 | 221 | 240 | 240 | 240 | 240 |
| | 5 kHz | 148 | 165 | 185 | 202 | 232 | 240 |
| | 10 kHz | 91 | 102 | 115 | 127 | 149 | 163 |

Table 23: Frequency-dependent maximum current for device size 18 peak power

¹⁾ ED: 70%, T_p: 35s

| Device size | | 19 | | | | | |
|---|----------------|--|-----|-----|-----|-----|-----|
| Rated switching frequency | | 4 (S1 operation), 8 (S3 operation) ¹⁾ | | | | | |
| Output frequency | f_{out} / Hz | 0 | 3 | 6 | 10 | 25 | 50 |
| Frequency-dependent maximum current @ f_s I_{out_max} / % Basic Time Period = 62.5 μ s (Parameter is22=0) | 2 kHz | 205 | 227 | 250 | 268 | 270 | 270 |
| | 4 kHz | 152 | 170 | 192 | 207 | 233 | 253 |
| | 8 kHz | 95 | 108 | 122 | 132 | 155 | 172 |
| | 16 kHz | 45 | 52 | 58 | 65 | 78 | 87 |
| Frequency-dependent maximum current @ f_s I_{out_max} / % Basic Time Period = 71.4 μ s (Parameter is22=1) | 1.75 kHz | 205 | 227 | 250 | 268 | 270 | 270 |
| | 3.5 kHz | 165 | 184 | 206 | 222 | 250 | 270 |
| | 7 kHz | 109 | 124 | 139 | 150 | 174 | 192 |
| | 14 kHz | 54 | 63 | 70 | 78 | 93 | 103 |
| Frequency-dependent maximum current @ f_s I_{out_max} / % Basic Time Period = 83.3 μ s (Parameter is22=2) | 1.5 kHz | 205 | 227 | 250 | 268 | 270 | 270 |
| | 3 kHz | 178 | 198 | 221 | 238 | 268 | 270 |
| | 6 kHz | 123 | 139 | 159 | 169 | 194 | 213 |
| | 12 kHz | 63 | 73 | 82 | 90 | 107 | 118 |
| Frequency-dependent maximum current @ f_s I_{out_max} / % Basic Time Period = 100 μ s (Parameter is22=3) | 1.25 kHz | 205 | 227 | 250 | 268 | 270 | 270 |
| | 2.5 kHz | 192 | 213 | 235 | 253 | 270 | 270 |
| | 5 kHz | 138 | 155 | 174 | 188 | 214 | 233 |
| | 10 kHz | 79 | 91 | 102 | 111 | 131 | 145 |

Table 24: Frequency-dependent maximum current for device size 19 peak power

¹⁾ ED: 70%, T_p : 10s

3.3.4 Overview of rectifier data for 400 V devices

| Device size | | 18 | 19 |
|---|---|-----|-----|
| Rectifier rated power | P_{rect} / kW | 25 | 34 |
| Rectifier continuous power | ¹⁾ P_{rect_cont} / kW | 61 | 61 |
| Continuous input current @ $U_N = 400V$ | ¹⁾ I_{in_cont} / A | 121 | 121 |
| Continuous input current @ $U_{N_UL} = 480V$ | ¹⁾ $I_{in_UL_cont}$ / A | 106 | 106 |
| Rated output current DC @ $U_{N_dc} = 565V$ | I_{out_dc} / A | 73 | 81 |
| Continuous output current DC @ $U_{N_dc} = 565V$ | ¹⁾ $I_{out_dc_cont}$ / A | 148 | 148 |
| Rated output current DC @ $U_{N_UL_dc} = 680V$ | $I_{out_UL_dc}$ / A | 58 | 73 |
| Continuous output current DC @ $U_{N_UL_dc} = 680V$ | ¹⁾ $I_{out_UL_dc_cont}$ / A | 129 | 129 |

Table 25: Overview of rectifier data for 400 V devices

¹⁾ Continuous operation is a load that exceeds the rated operation. Continuous operation only occurs if the internal rectifier is used to supply additional drive controllers via the DC terminals => „5.3.6 DC-bus connection“. In continuous operation, the OH error can be triggered depending on the operating conditions of the internal inverter.

3.3.5 Power dissipation at rated operation of the 400 V peak power devices

| Device size | | 18 | 19 |
|---|-------------------------------|--|--|
| Rated switching frequency | f_{SN} / kHz | 4 (S1 operation), 8 (S3 operation) ³⁾ | 4 (S1 operation), 8 (S3 operation) ⁴⁾ |
| Power dissipation at rated operation | ¹⁾ P_D / W | 558 | 698 |
| Power dissipation at rated operation DC | ²⁾ P_{D_dc} / W | 484 | 560 |

Table 26: Power dissipation of the 400 V peak power devices

- ¹⁾ Rated operation corresponds to $U_N = 400$ V; f_{SN} ; I_N ; $f_N = 50$ Hz (typically value)
- ²⁾ Rated operation DC corresponds to $U_{N_dc} = 565$ V; I_N ; $f_N = 50$ Hz (typically value)
- ³⁾ ED: 70%, T_p : 35s
- ⁴⁾ ED: 70%, T_p : 10s

3.3.6 Fusing for 400 V peak power devices

3.3.6.1 Fuse protection for AC supply

| Device size | Max. size of the fuse / A | | | |
|-------------|---------------------------|--------------------------------|---------------------|--|
| | $U_N = 400$ V gG (IEC) | $U_N = 480$ V / 277V Class „J“ | $U_{N_UL} = 480$ V | |
| | SCCR 30 kA | SCCR 5 kA | SCCR 30 kA | Type |
| 18 | 80 | 60 | 50 | SIBA 20 189 20.50 EATON 170M1364 LITTELFUSE L70QS050 |
| 19 | 80 | 80 | 80 | SIBA 20 189 20.80 EATON 170M1366 |

Table 27: Fusings for 400 V peak power devices



Short-circuit capacity

According to requirements from *EN 61439-1* and *EN 61800-5-1*, the following applies to connection to a mains supply: The devices are suitable for use in a circuit capable of delivering not more than 30 kA eff. unaffected symmetrical short-circuit current.

3.3.6.2 Fuse protection for DC supply

| Device size | Recommended size of the fuse / A | | Permissible fuses ¹⁾ |
|-------------|----------------------------------|------------------------|---|
| | $U_{N_dc} = 565V$ | $U_{N_UL_dc} = 680V$ | |
| | SCCR 50 kA | SCCR 50 kA | |
| 18 | 100 | 80 | SIBA 50 250 06.80 SIBA 50 280 06.100 SIBA 20 209 37.100 ²⁾ SIBA 50 268 06.125 SIBA 20 557 34.250 ²⁾ SIBA 20 031 34.250 Busmann FWP-100A22F Busmann 170M1422 Littelfuse L70QS500 |
| 19 | 125 | 100 | |

Table 28: DC Fusing of the 400 V / 480 V devices

- ¹⁾ Fuses of the same type with lower rated currents can be used if they are suitable for the application.
- ²⁾ Fuse without UL certification.

NOTICE

Observe the rated voltage of the fuse!

- ▶ The rated voltage of the fuse must be at least equal to the maximum DC supply voltage of the drive controller.

3.3.6.3 Motor protective circuit-breaker / circuit breaker

This chapter lists the recommended and alternative motor protection switches/circuit breakers for protecting the drive controller. The selection of the recommended protection switches is based on continuous operation (S1 operation) at 100% load and maximum ambient temperature. If operating conditions differ, the circuit breakers must be dimensioned accordingly (see manufacturer’s documentation for the respective circuit breakers).

| Device size | Recommended motor-protective circuit-breakers / circuit-breakers | | | | | | |
|-------------|--|-------------------|-------------------|--------------------------|-------------------|------------------|-------------------------|
| | IEC($U_N = 400V$) | | | UL($U_{N_UL} = 480V$) | | | |
| | Type | Rated current / A | SCCR @ U_N / kA | Type | Rated current / A | Rated power / hp | SCCR @ U_{N_UL} / kA |
| 18 | Eaton PKZM4-63 | 63 | 30 | Eaton PKZM4-50 | 50 | 30 | 30 |
| 19 | Eaton NZ-MN1-A80-NA | 80 | 30 | Eaton PKZM4-58 | 58 | 40 | 30 |

Table 29: Recommended motor protective circuit-breakers / circuit breakers for 400 V / 480 V appliances

As an alternative to the recommended motor protection switches/circuit breakers, all circuit breakers listed in the following table may be used. Circuit breakers of the same type with a lower rated current or other features (e.g., connection terminals, actuation types, etc.) may also be used, provided that they are suitable for the application and the differing features do not have a negative effect on the pass values (I^2t and I_p). Circuit breakers of the same type with lower breaking capacity may be used provided they are suitable for the application. In this case, the short-circuit current rating (SCCR) of the combination of drive controller and circuit breaker is reduced to the breaking capacity of the circuit breaker.

Some motor circuit breakers require additional accessories in order to be used as Type E Combination Motor Controllers in UL-certified installations (see manufacturer’s documentation for the respective circuit breaker).

| Alternative motor-protective circuit-breaker / circuit-breaker | | | |
|--|-------------------|------------------|-------------------|
| Type | Rated current / A | Rated power / hp | SCCR @ U_N / kA |
| Eaton PKZM4-63 | 65 | 40 | 30 |
| Siemens 3RV2032-4KA10 | 73 | 60 | 30 |
| Siemens 3RV2042-4MA10 | 100 | 75 | 30 |
| Schneider GV3P65 | 65 | 40 | 30 |
| Eaton NZMN1-A125-NA | 125 | – | 30 |
| Eaton NZMH2-A160-NA | 160 | – | 30 |
| Siemens 3VA5112-6ED31-0AA0 | 125 | – | 30 |
| Siemens 3VA5215-6ED31-0AA0 | 150 | – | 30 |
| Schneider B JL36125 | 125 | – | 30 |

Table 30: Alternative motor protective circuit-breakers / circuit breaker for 400 V / 480 V appliances



IEC only:

Motor-protective circuit-breakers / circuit-breakers not listed here can be used provided they fulfil the following requirements:

- Passage integral I^2t @ $U_N < 910kA^2s$
- Forward current I_p @ $U_N < 18kA$

3.4 General electrical data

3.4.1 Switching frequency and temperature

The drive controller cooling is designed by way that the heat sink overtemperature threshold is not exceeded at rated conditions. A switching frequency higher than the rated switching frequency also produces higher losses and thus a higher heat sink heating. If the heat sink temperature reaches a critical threshold (T_{DR}), the switching frequency can be reduced automatically step by step. This prevents that the drive controller switches off due to overheating of the heat sink. If the heat sink temperature falls below the threshold T_{UR} , the switching frequency is increased back to the setpoint. At temperature T_{EM} the switching frequency is immediately reduced to rated switching frequency. „Derating“ must be activated, for this function to work.

3.4.1.1 Switching frequency and temperature of the 230 V peak power devices

| Device size | | 16 | 17 |
|--|----------------------------------|----|----|
| Rated switching frequency | ¹⁾ f_{SN} / kHz | 8 | 8 |
| Max. switching frequency | ¹⁾ f_{S_max} / kHz | 16 | 16 |
| Min. switching frequency | ¹⁾ f_{S_min} / kHz | 2 | 2 |
| Max. heat sink temperature | T_{HS} / °C | 90 | 90 |
| Temperature for derating the switching frequency | T_{DR} / °C | 80 | 80 |
| Temperature for uprating the switching frequency | T_{UR} / °C | 70 | 70 |
| Temperature for switching to rated switching frequency | T_{EM} / °C | 85 | 85 |

Table 31: Switching frequency and temperature for 230 V peak power devices

¹⁾ The output frequency is to be limited in such a way that it does not exceed 1/10 of the switching frequency.

3.4.1.2 Switching frequency and temperature of the 400 V peak power devices

| Device size | | 18 | 19 |
|--|----------------------------------|---|---|
| Rated switching frequency | ¹⁾ f_{SN} / kHz | 4 (S1 operation), 8 (S3 operation) ²⁾ | 4 (S1 operation), 8 (S3 operation) ³⁾ |
| Max. switching frequency | ¹⁾ f_{S_max} / kHz | 16 | 16 |
| Min. switching frequency | ¹⁾ f_{S_min} / kHz | 2 | 2 |
| Max. heat sink temperature | T_{HS} / °C | 90 | 90 |
| Temperature for derating the switching frequency | T_{DR} / °C | 80 | 80 |
| Temperature for uprating the switching frequency | T_{UR} / °C | 70 | 70 |
| Temperature for switching to rated switching frequency | T_{EM} / °C | 85 | 85 |

Table 32: Switching frequency and temperature for 400 V peak power devices

¹⁾ The output frequency is to be limited in such a way that it does not exceed 1/10 of the switching frequency.

²⁾ ED: 70%, T_p : 35s

³⁾ ED: 70%, T_p : 10s

3.4.2 DC link / braking transistor function



Activation of the braking transistor function

To be able to use the braking transistor, the function must be activated with parameter "is30 braking transistor function".

For more information => [F6 Programming manual](#).

NOTICE

Falling below the minimum braking resistor value!

Destruction of the drive controller

- ▶ The minimum brake resistance value must not fall below!

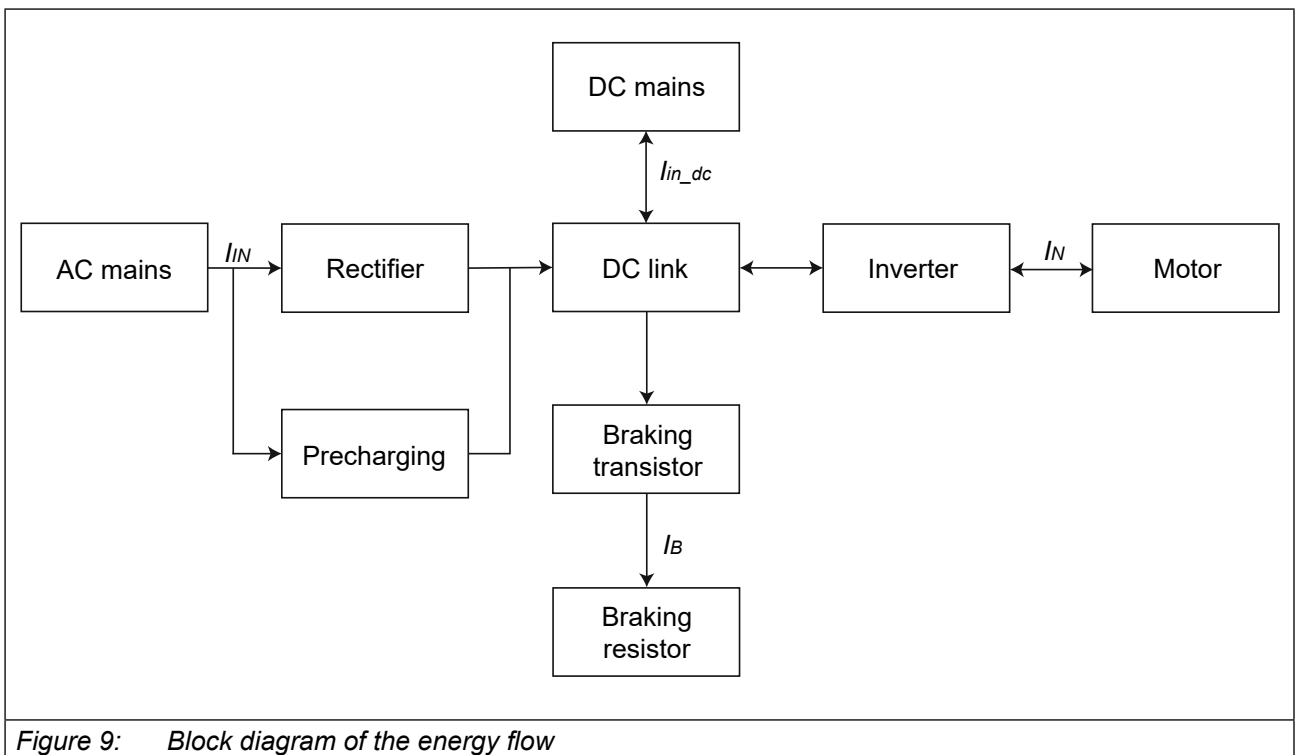

Figure 9: Block diagram of the energy flow

NOTICE

Destruction of the drive controller!

If the error "ERROR GTR7 always ON" occurs, the current consumption is switched off internally via the mains input bridge of the AC supply.

- ▶ If the error "ERROR GTR7 always ON" occurs, the drive controller is defective and must be disconnected from the power supply no later than 16 hours!
- ▶ With DC mains connection and the use of non-intrinsically safe braking resistors or sub-mounted braking resistors, the drive controller must be de-energised after 1 second at the latest.

3.4.2.1 DC link / braking transistor function of the 230V peak power devices

| Device size | | 16 | 17 |
|--|--------------------------------|---|-----------|
| Rated DC link voltage @ $U_N = 230\text{ V}$ | U_{N_dc} / V | 325 | 325 |
| Rated DC link voltage @ $U_{N_UL} = 240\text{V}$ | $U_{N_dc_UL} / \text{V}$ | 339 | 339 |
| DC link voltage working voltage range | U_{in_dc} / V | 240...373 | 240...373 |
| DC switch-off level "ERROR underpotential" | U_{UP} / V | 216 | 216 |
| DC switch-off level "ERROR overpotential" | U_{OP} / V | 400 | 400 |
| DC switch-off level braking transistor | ¹⁾ U_B / V | 380 | 380 |
| Max. braking current | I_{B_max} / A | 93 | 105 |
| Braking transistor | ²⁾ | Max. cycle time: 120s; Max c.d.f.: 50 % | |
| Min. braking resistor value | R_{B_min} / Ω | 4,5 | 4 |
| Protective function braking resistor (Error GTR7 always on) | ³⁾ | Feedback signal evaluation and current switch-off | |
| Protective function for braking transistor | | Short-circuit monitoring | |
| DC link capacity | $C / \mu\text{F}$ | 6120 | 6800 |

Table 33: DC link / braking transistor function of the 230V peak power devices

- ¹⁾ The DC switching level for the braking transistor is adjustable. The default value is the value specified in the table.
- ²⁾ The cyclic duration factor is additionally limited by the used braking resistor. Values apply to external braking resistors.
- ³⁾ The feedback signal evaluation monitors the functionality of the braking transistor. The power is switched off via the internal mains input bridge of the AC supply.

3.4.2.2 DC link / braking transistor function of the 400 V peak power devices

| Device size | | 18 | 19 |
|--|---------------------------------|--|-----------|
| Rated DC link voltage @ $U_N = 400\text{ V}$ | U_{N_dc} / V | 565 | 565 |
| Rated DC link voltage @ $U_{N_UL} = 480\text{V}$ | $U_{N_dc_UL} / \text{V}$ | 680 | 680 |
| DC link voltage working voltage range | U_{in_dc} / V | 390...780 | 390...780 |
| DC switch-off level "ERROR underpotential" | U_{UP} / V | 240 | 240 |
| DC switch-off level "ERROR overpotential" | U_{OP} / V | 840 | 840 |
| DC switch-off level braking transistor | ¹⁾ U_B / V | 780 | 780 |
| Max. braking current | I_{B_max} / A | 93 | 105 |
| Braking transistor | ²⁾ | Max. cycle time: 120 s; Max c.d.f.: 50 % | |
| Min. braking resistor value | R_{B_min} / Ω | 9 | 8 |
| Protective function braking resistor (Error GTR7 always on) | ³⁾ | Feedback signal evaluation and current switch-off (only for AC connection) | |
| Protective function for braking transistor | | Short-circuit monitoring | |
| DC link capacity | $C_{int} / \mu\text{F}$ | 1700 | 2380 |
| Max. prechargeable total capacity @ $U_N = 400\text{V}$ | $C_{pc_max} / \mu\text{F}$ | 5700 | 9500 |
| Max. prechargeable total capacity @ $U_{N_UL} = 480\text{V}$ | $C_{pc_max_UL} / \mu\text{F}$ | 3900 | 6600 |

Table 34: DC link / braking transistor function of the 400 V peak power devices

- ¹⁾ The DC switching level for the braking transistor is adjustable. The default value is the value specified in the table.
- ²⁾ The cyclic duration factor is additionally limited by the used braking resistor. Values apply to external braking resistors.
- ³⁾ The feedback signal evaluation monitors the functionality of the braking transistor. The power is switched off via the internal mains input bridge of the AC supply. There is no current switch-off with DC supply.

3.4.3 Fan

| Device size | | 16 | 17 | 18 | 19 |
|---------------|----------------|-----|----|----|----|
| Interior fan | Number | 1 | | | |
| | Speed-variable | Yes | | | |
| Heat sink fan | Number | 2 | | | |
| | Speed-variable | Yes | | | |

Table 35: Fan



The fans are speed-variable. They are automatically controlled to high or low speed depending on the temperature limits set in the software.

NOTICE**Destruction of the fan!**

- Take care that no foreign substances drop into the fan!

3.4.3.1 Switching behaviour of the fans

The temperature monitoring system controls the fans with different switch-on and switch-off points.

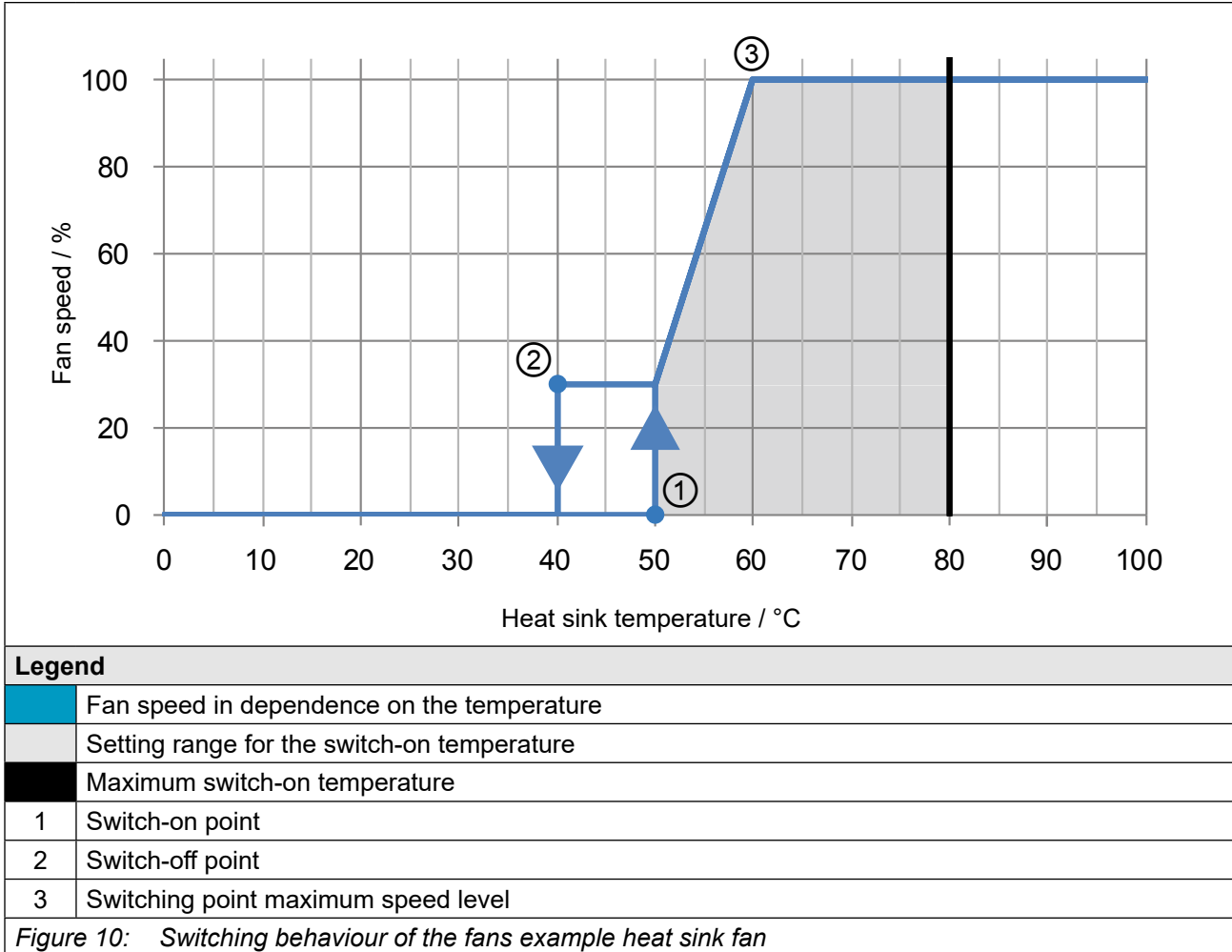

3.4.3.2 Switching points of the fans

The switching point for the switch-on temperature and the maximum speed level of the fans are adjustable. The following table shows the default values.

| Fan | | Heat sink | Interior |
|-----------------------|----------------------|-----------|----------|
| Switch-on temperature | $t / ^\circ\text{C}$ | 50 | 45 |
| Maximum speed level | $t / ^\circ\text{C}$ | 60 | 55 |

Table 36: Switching points of the fans

4 Installation

4.1 Dimensions and weights

4.1.1 Built-in version air cooler

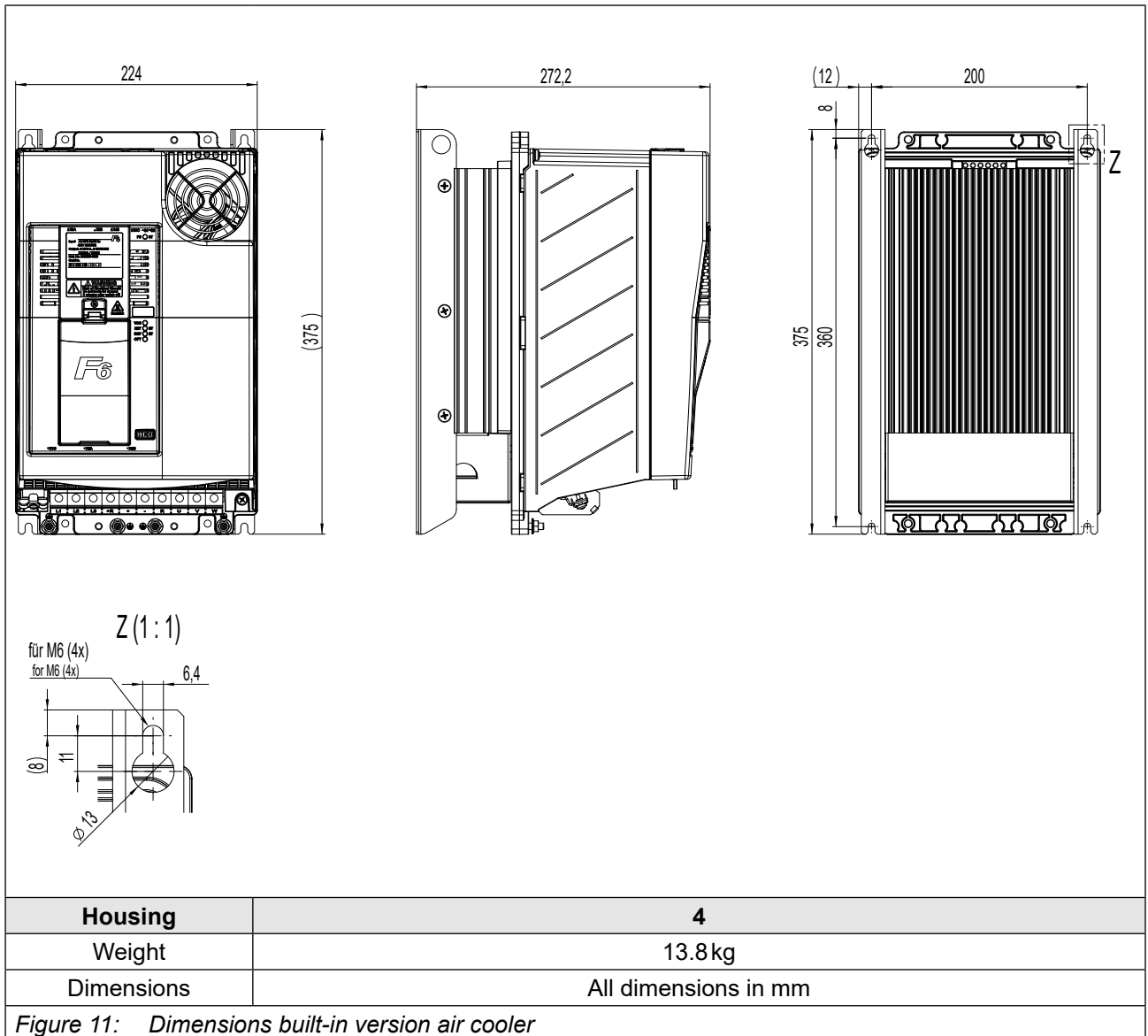

4.1.2 Push-through version air cooler IP20, IP54-ready

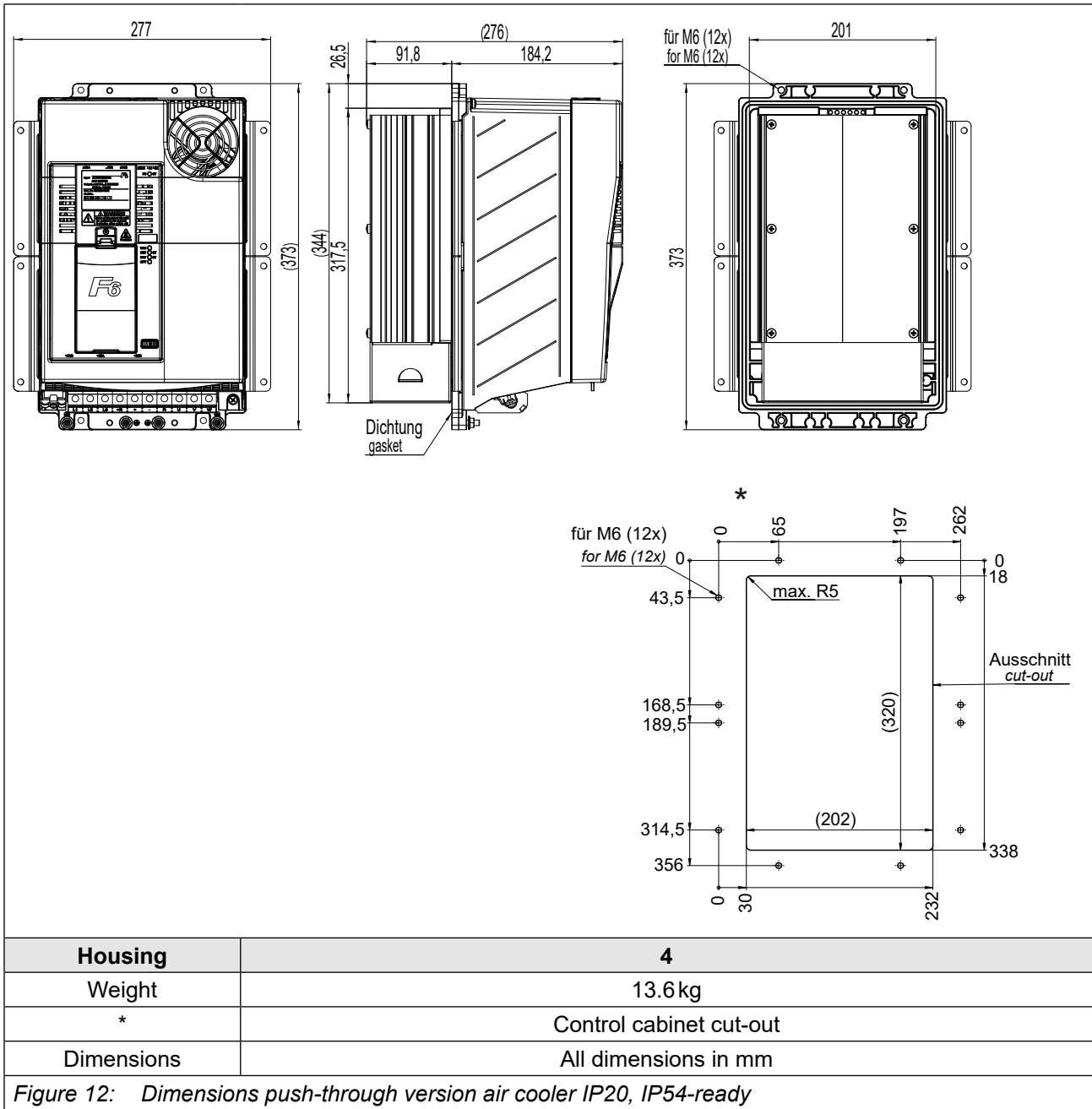

4.2 Control cabinet installation

4.2.1 Mounting instructions

For the mounting of the drive controllers the following mounting materials with the appropriate quality were tested by KEB.

| Required material | Tightening torque |
|---|-------------------|
| Hexagon head screw <i>ISO 4017</i> - M6 - 8.8 | 9Nm 79lb inch |
| Flat washer <i>ISO 7090</i> - 6 - 200 HV | – |
| <i>Table 37: Mounting instructions for built-in version</i> | |

| Required material | Tightening torque |
|--|-------------------|
| Hexagon head screw <i>ISO 4017</i> - M6 - 8.8 | 9Nm 79lb inch |
| Flat washer <i>ISO 7090</i> - 6 - 200 HV | – |
| <i>Table 38: Fastening instructions for push-through version</i> | |

NOTICE

Use of other fixing material

- The alternatively selected fixing material must meet the above material characteristics (quality) and tightening torques!

The use of other fixing materials is beyond the control of KEB and is therefore the sole responsibility of the customer.

4.2.2 Mounting distances

Power dissipation for control cabinet design => „3.3.5 Power dissipation at rated operation of the 400 V peak power devices“. A lower value can be used here depending on the operating mode/load.



Mounting the drive controller

For reliable operation, the drive controller must be mounted without any distance on a smooth, closed, metallicly bright mounting plate.

| Mounting distances | Dimension | Distance in mm | Distance in inch |
|--------------------|---|----------------|------------------|
| | A | 150 | 6 |
| | B | 100 | 4 |
| | C | 30 | 1,2 |
| | D | 0 | 0 |
| | E | 0 | 0 |
| | F ¹⁾ | 50 | 2 |
| | ¹⁾ Distance to preceding elements in the control cabinet door. | | |

Figure 13: Mounting distances

4.2.3 Installation of IP54-ready devices

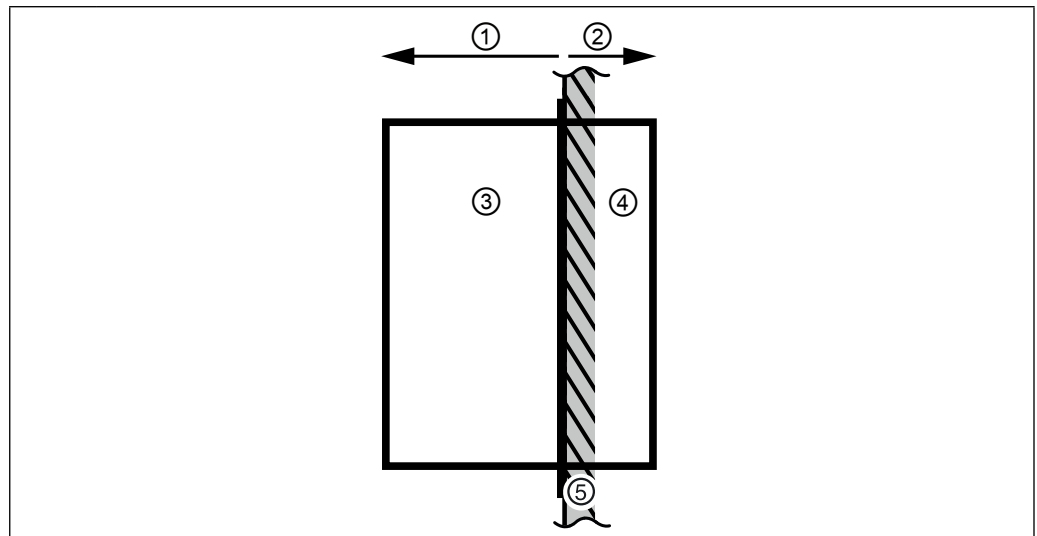

Legend

| | |
|---|--|
| 1 | IP20 zone inside the housing |
| 2 | IP54 zone outside the housing |
| 3 | Drive controller (power unit and control unit) |
| 4 | Drive controller (heat sink) |
| 5 | Housing (e.g. Control cabinet wall) |

Figure 14: Installation of IP54-ready devices



IP54 zone: Heat sink outside the housing (Control cabinet)

The protection class IP54 can only be achieved when the device is properly installed.

For proper installation, a suitable IP54 seal (=> „5.4.2 Seal for IP54-ready devices“) must be installed between heat sink and housing (e.g. control cabinet wall).

The tightness must be checked after the installation. If properly installed, the separation to the housing corresponds to degree of protection IP54.

In the case of fan-cooled units, the fans must be protected from negative environmental influences.

These include combustible, oily or dangerous fumes or gases, corrosive chemicals, coarse foreign bodies and excessive dust. This applies especially to the access of the heatsink from the top (air outlet). Icing is inadmissible.

UL: Device heat sink is classified as NEMA type 1

IP20 zone: Device inside the housing

This part is intended for the installation in a suitable housing for the required degree of protection (e.g. control cabinet).

The power connections are excluded => „3.1.1 Climatic environmental conditions“.

NOTICE

Defect due to continuous splash water !

- ▶ Never expose the device to continuous splashing water (e.g. direct exposure to rain)!

4.2.4 Control cabinet ventilation

If construction-conditioned the control cabinet cannot be without indoor ventilation, appropriate filters must avoid suction of foreign objects.

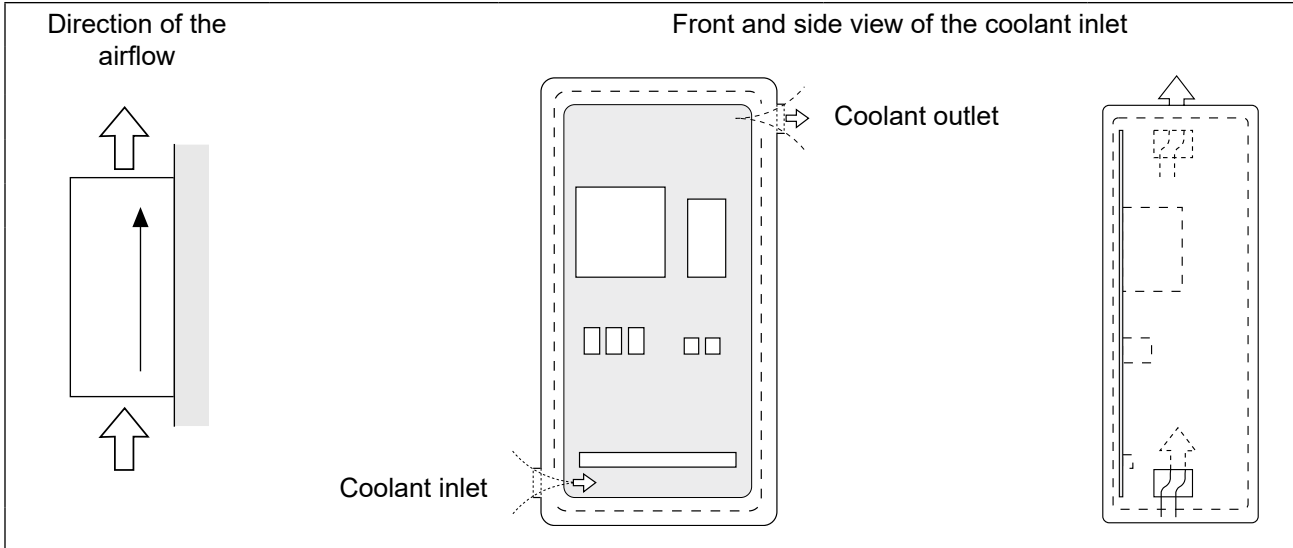
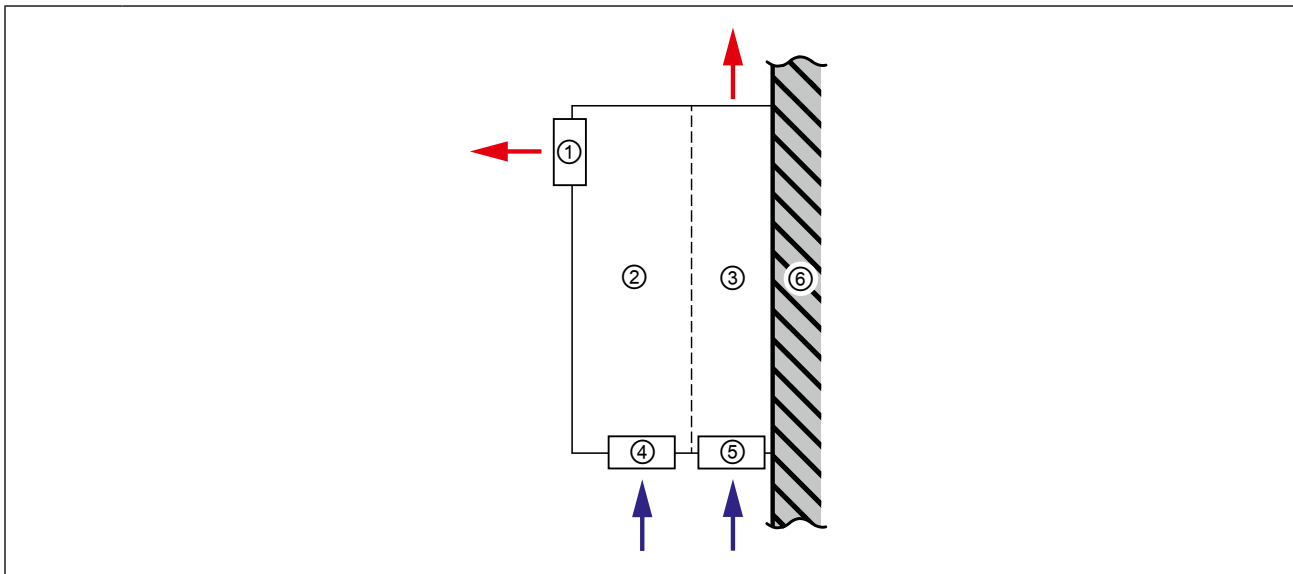

Figure 15: Control cabinet ventilation

4.2.5 Airflow of the drive controller



| Legend | |
|--------|--|
| | Airflow direction |
| 1 | Interior fan (from housing 4) |
| 2 | Drive controller (power unnit and control) |
| 3 | Drive controller (heat sink) |
| 4 | Interior fan for (housing 2 and 3) |
| 5 | Heatsink fan |
| 6 | Housing (e.g. Control cabinet rear) |

Figure 16: Airflow of the drive controller

5 Installation and connection

5.1 Overview of the COMBIVERT F6

| Housing 4 | | No. | Name | Description |
|-----------|---|-----|---|-------------|
| | 1 | – | Shield clamps for shielded control cables. | |
| | 2 | – | Fixing points for optional shield connection bracket. The shielding e.g. from the motor cable is laid on the mounting plate in the control cabinet or on the shield connection bracket 00F6V80-4001 (optionally available). | |
| | 3 | – | LEDs (=> manual for control unit chapter "Overview") <ul style="list-style-type: none"> • For control board COMPACT: FS without function. • For control board APPLICATION and PRO: Status indication of the safety module | |
| | 4 | – | Interior fan | |
| | 5 | – | Nameplates | |
| | 6 | PE | Protective earth; when connecting the protective earth, each connection point may only be used once. | |
| | 7 | X1A | Power circuit terminals for: <ul style="list-style-type: none"> • Mains input • Braking resistor • DC supply • Motor connection | |

Figure 17: F6 housing 4 top view

| Housing 4 | | No. | Name | Description | | | |
|-----------|----|-----|---|-------------|---|----|---|
| | 1 | – | Shield clamps for shielded control cables. | | | | |
| | 6 | PE | Protective earth; when connecting the protective earth, each connection point may only be used once. | | | | |
| | 7 | X1A | Power circuit terminals for: <ul style="list-style-type: none"> • Mains input • Braking resistor • DC supply • Motor connection | | | | |
| | 8 | X1C | Terminal for: <ul style="list-style-type: none"> • Motor temperature monitoring • Brake control | | | | |
| | 9 | X3A | Encoder interface channel A | | | | |
| | 10 | X3B | Encoder interface channel B | | | | |
| | 11 | – | Heat sink fan | | | | |
| | 1 | 6 | 11 | 6 | 6 | 11 | 6 |
| | 1 | 6 | 11 | 6 | 6 | 11 | 6 |
| | 1 | 6 | 11 | 6 | 6 | 11 | 6 |

Figure 18: F6 housing 4 front view

| Housing 4 | | No. | Name | Description |
|-----------|----|-----|---|-------------|
| | 4 | – | Interior fan | |
| | 12 | X4C | Fieldbus interface (out) | |
| | 13 | X4B | Fieldbus interface (in) | |
| | 14 | X2C | Control terminal block for <ul style="list-style-type: none"> • CAN bus • Analog inputs and analog output | |
| | 15 | X2B | Safety functions / 24 V DC voltage supply / 2 digital outputs | |
| | 16 | X2A | Control terminal block for digital inputs and outputs. | |
| | 17 | – | Shield clamps for shielded control cables. | |

Figure 19: F6 housing 4 rear view with control board COMPACT



Further information can be found in the respective control board manual.



Instructions for use COMBIVERT F6 control board APPLICATION
www.keb.de/fileadmin/media/Manuals/dr/ma_dr_f6-cu-a-inst-20118593_en.pdf



Instructions for use COMBIVERT F6 control board COMPACT
www.keb.de/fileadmin/media/Manuals/dr/ma_dr_f6-cu-k-inst-20144795_en.pdf



Instructions for use COMBIVERT F6 control board PRO
www.keb.de/fileadmin/media/Manuals/dr/ma_dr_f6-cu-p-inst-20182705_en.pdf



5.2 Connection of the power unit

NOTICE

Destruction of the drive controller!

- ▶ Never exchange mains input and motor output!

5.2.1 Connection of the voltage supply

The COMBIVERT F6 can be supplied via terminals L1, L2 and L3 (AC power supply) or via terminals + and - (DC power supply with inrush current limitation)

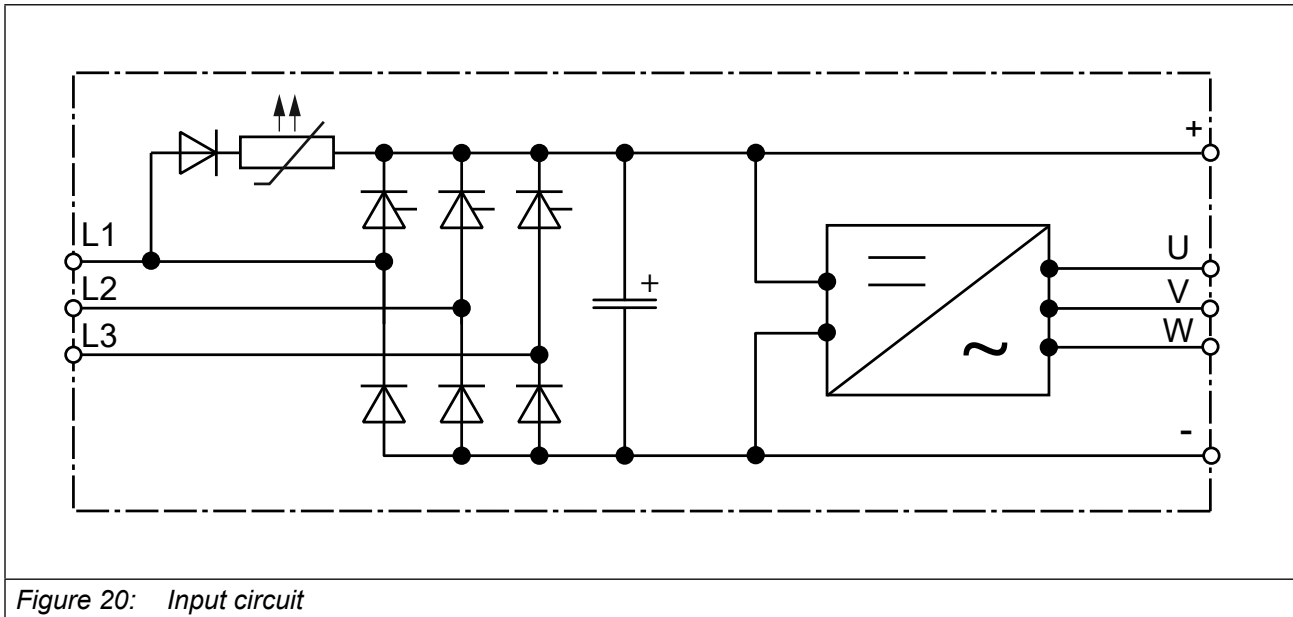

Figure 20: Input circuit

NOTICE

With AC power supply, observe the minimum waiting time between two switch-on procedures!

Cyclical switching off and on of the drive controller leads to temporary high impedance of the PTC precharging resistor. After the PTC precharging resistor has cooled down, it can be restarted without restrictions. The waiting time between two switch-on processes depends on the external capacitance, the AC mains voltage and the ambient temperature.

- ▶ Without external capacity: 5 min
- ▶ With external capacity (additional drive controllers): 20 min

NOTICE

No inrush current limitation with DC power supply!

- ▶ An external inrush current limiter must be provided for DC power supplies.

5.2.1.1 Terminal block X1A

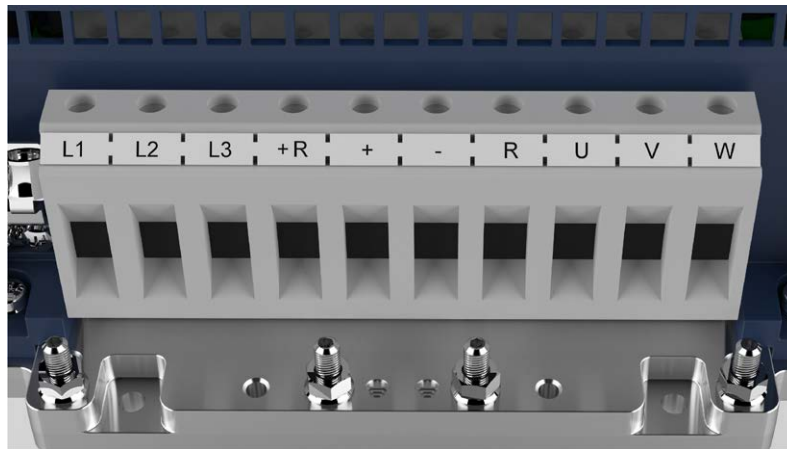

| Name | Function | Cross-section for terminal connection | Tightening torque | Max. number of conductors |
|------|--|--|---------------------------------|-----------------------------|
| L1 | Mains connection 3-phase | Flexible cable with wire end ferrule 1.5...35 mm ² (without wire end ferrule up to max. 50 mm ²) For 2 conductors max. 16 mm ² UL: Flexible cable without wire-end ferrule AWG 16...1 | 3.2...3.7 Nm 28...32 lb inch | For IEC: 2 For UL: 1 |
| L2 | | | | |
| L3 | | | | |
| +R | Connection for braking resistor (between +R and R) | | | |
| + | DC terminals | | | |
| - | | | | |
| R | Connection for braking resistor (between +R and R) | | | |
| U | Motor connection | | | |
| V | | | | |
| W | | | | |

Figure 21: Terminal block X1A

5.2.2 Protective earth and functional earth



Protective and functional earth must not be connected to the same terminal.

5.2.2.1 Protective earth

The protective earth (PE) serves for electrical safety particularly personal protection in error case.



Electric shock due to incorrect dimensioning!



► The earthing cross-section complies with *VDE 0100* !

| Name | Function | Connection type | Tightening torque |
|------|---------------------------------|--|---------------------------------|
| PE, | Connection for protective earth | M6 threaded pin with nut for 6.5 mm crimp connectors | 6.1...12 Nm 54...106 lb inch |

Figure 22: Connection for protective earth



Incorrect installation of the PE connection

Only the M6 threaded pins with nut may be used to connect the protective earth!

5.2.2.2 Functional earthing

A functional earthing may also be necessary, if for EMC requirements additional potential equalization between devices or parts of the system must be available.



The use of the functional earth (FE) is not required if the frequency inverter is EMC-technically wired.

The functional earth may not be wired green/yellow!



Notes on EMC-compatible installation can be found here.
www.keb.de/fileadmin/media/Manuals/emv/0000neb0000.pdf



5.3 Mains connection

5.3.1 Supply cable

The conductor cross-section of the supply cable is determined by the following factors:

- Input current of the drive controller
- Used line type
- Installation and ambient temperatures
- The locally valid electrical regulations



The application engineer is responsible for the design!

5.3.2 AC mains connection

5.3.2.1 AC supply 3-phase

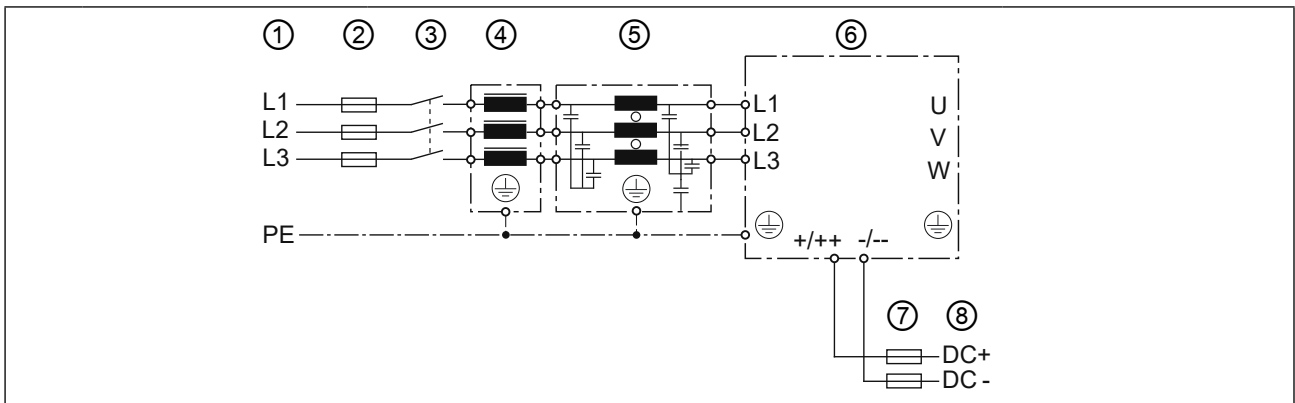

| No. | Type | Description |
|---|-------------------------------|---|
| 1 | Mains phase | 3-phase |
| | Mains form | TN, TT |
| | | IT |
| The rated voltage between one phase conductor and earth potential (or the neutral point in the IT system) must not exceed 300V. (For the IT system, a short-term disconnection must be ensured). | | |
| | Personal protection | RCMA with separator or RCD type B Insulation monitors |
| 2 | Mains fuses | see chapter "Protection of the drive controllers" |
| 3 | Mains contactor | - |
| 4 | Mains choke | see notes in chapter "Filters and chokes" |
| 5 | HF filter for TN-, TT systems | Required for compliance with the limit values in accordance with EN 61800-3 . |
| | HF filter for IT systems | |
| 6 | Drive controller | COMBIVERT F6 |
| 7 | DC-fuses | See note in chapter „Fusing of the devices“. |
| 8 | DC-supply | DC supply generated by the drive controller for connecting further drive controllers => „5.3.6 DC-bus connection“ |

Figure 23: Connection of the mains supply 3-phase

5.3.2.2 Note on hard power systems

The service life of drive controllers with voltage DC link depends on the DC voltage, ambient temperature and the current load of the electrolytic capacitors in the DC link. The use of mains chokes can increase the service life of the condensators to a considerable extent, especially when connecting to "hard" power systems or when under permanent drive load (continuous duty).

The term "hard" power system means that the nodal point power (S_{Net}) of the mains is very high ($\gg 200$) compared to the rated apparent output power of the drive controller (S_{out}).

| | | | |
|---------------------------------------|------|---|-------------------|
| $k = \frac{S_{Net}}{S_{out}} \gg 200$ | e.g. | $k = \frac{2 \text{ MVA (supply transformer)}}{62 \text{ kVA (21F6)}} = 33 \longrightarrow$ | no choke required |
|---------------------------------------|------|---|-------------------|



A listing of filters and chokes => „5.4.1 Filters and chokes“

5.3.3 DC mains connection

NOTICE

DC operation

► The DC power supply of 230V devices is only permitted after consultation with KEB!

5.3.3.1 Terminal block X1A DC connection

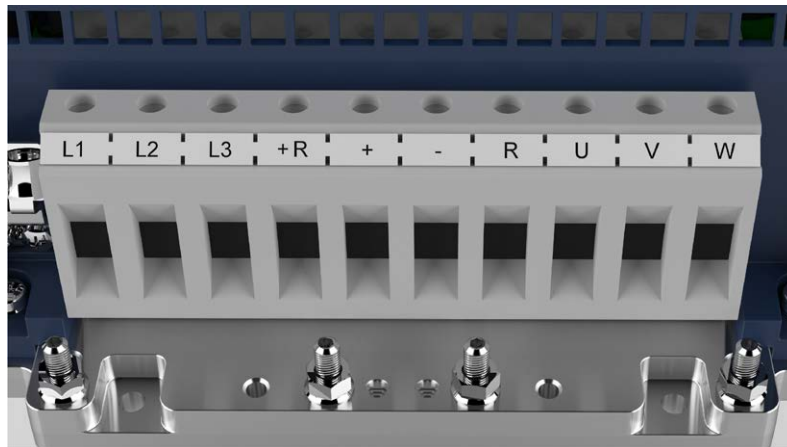

| Name | Function | Cross-section for terminal connection | Tightening torque | Max. number of conductors |
|------|--------------|--|---------------------------------|-----------------------------|
| + | DC terminals | Flexible cable with wire end ferrule 1.5...35 mm ² (without wire end ferrule up to max. 50 mm ²) For 2 conductors max. 16 mm ² | 3.2...3.7 Nm 28...32 lb inch | For IEC: 2 For UL: 1 |
| - | | UL: Flexible cable without wire-end ferrule AWG 16...1 | | |

Figure 24: Terminal block X1A DC connection

5.3.3.2 Connection at DC voltage supply

NOTICE

Destruction of the drive controller!

► Never exchange “+ / ++” and “- / --”!

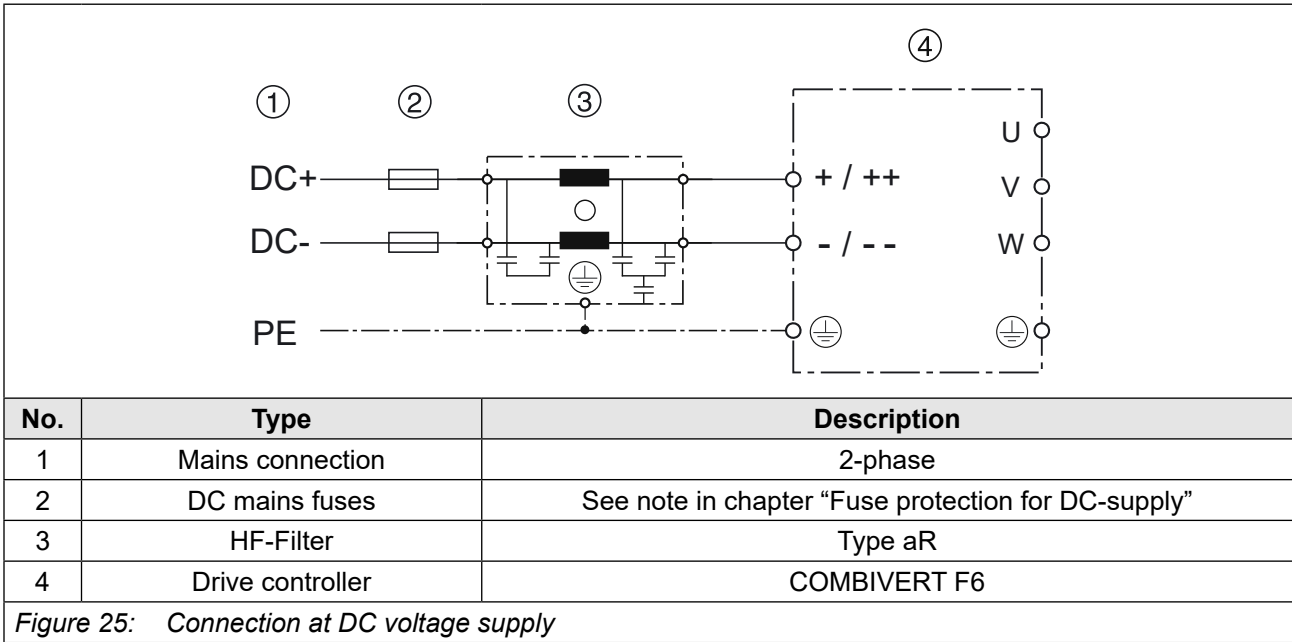
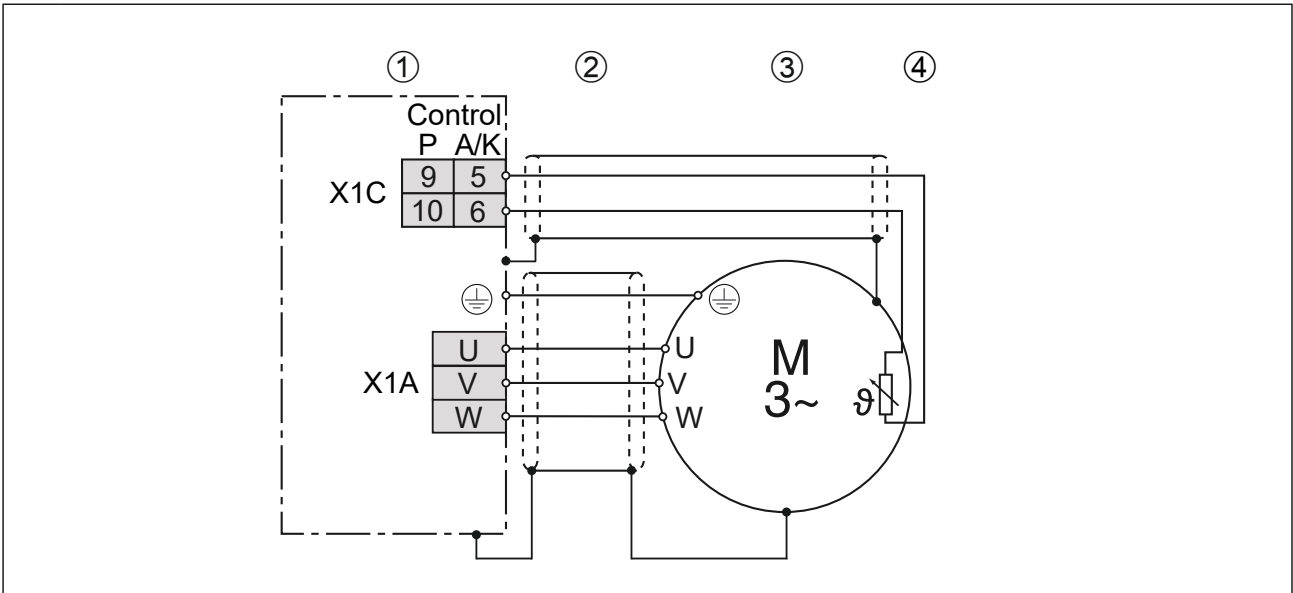

Figure 25: Connection at DC voltage supply

5.3.4 Connection of the motor

5.3.4.1 Wiring of the motor



Legend

| | |
|---|--|
| 1 | KEB COMBIVERT |
| 2 | Apply motor cable, shielding on both sides over a large surface on the bare metallic frame or mounting plate (remove paint if necessary) |
| 3 | Three-phase motor |
| 4 | Temperature monitoring (optional) => <i>Instructions for use "Control circuit"</i> |

Figure 26: Wiring of the motor

5.3.4.2 Terminal block X1A motor connection

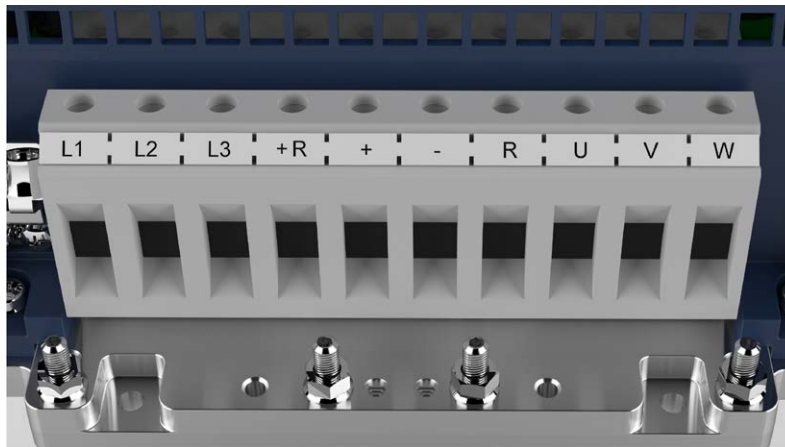

| Name | Function | Cross-section for terminal connection | Tightening torque | Max. number of conductors |
|------|------------------|--|---------------------------------|-----------------------------|
| U | Motor connection | Flexible cable with wire end ferrule 1.5...35 mm ² (without wire end ferrule up to max. 50 mm ²) For 2 conductors max. 16 mm ² UL: Flexible cable without wire-end ferrule AWG 16...1 | 3.2...3.7 Nm 28...32 lb inch | For IEC: 2 For UL: 1 |
| V | | | | |
| W | | | | |

Figure 27: Terminal block X1A motor connection

5.3.4.3 Selection of the motor line

The correct cabling as well as the motor line itself play an important part in case of low power in connection with long motor line lengths. Low-capacitance line (phase/phase < 65 pF/m, phase/screen < 120 pF/m) at the inverter output have the following effects:

- allow major motor line lengths („5.3.4.4 Motor cable length and conducted interferences at AC supply“)
- better EMC properties (reduction of the common-mode output currents to earth)

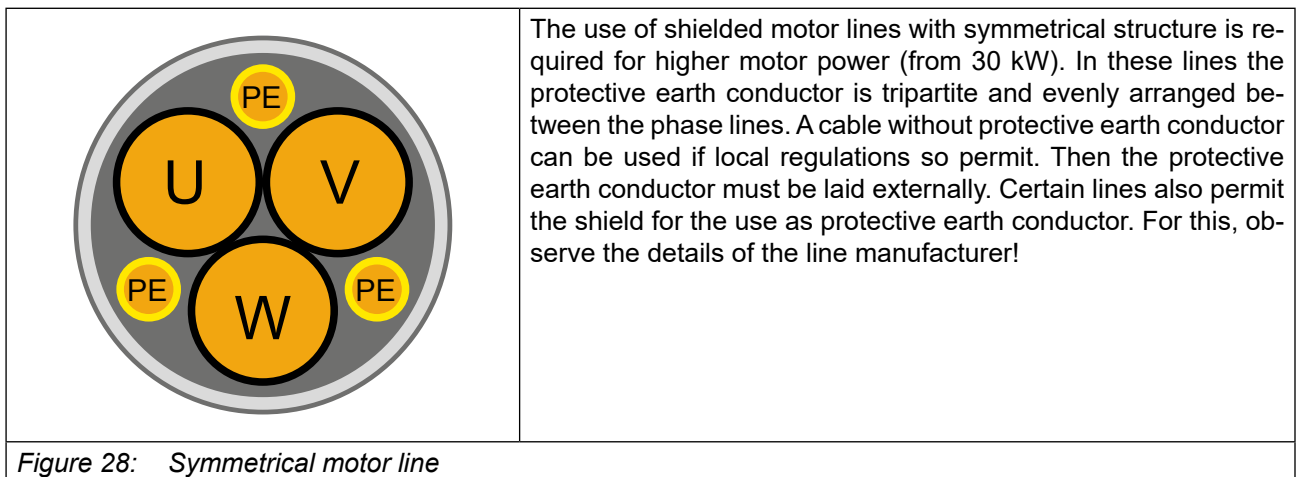

5.3.4.4 Motor cable length and conducted interferences at AC supply

The maximum motor cable length is depending on the capacity of the motor cable as well as on the EMC emitted interference. External measures must be taken here (e.g. the use of a line filter).



The cable length can be significantly increased by using motor chokes or motor filters. KEB recommends the use of motor chokes or filters for a cable length upto 25m.



Further information on the motor cable length can be found in the corresponding filter instructions.

5.3.4.5 Motor cable length for parallel operation of motors

The resulting motor cable length for parallel operation of motors, or parallel installation with multiple cables arises from the following formula:

$$\text{Resulting motor cable length} = \sum \text{single cable length} \times \sqrt{\text{Number of motor cables}}$$

5.3.4.6 Motor cable cross-section

The motor cable cross-section is dependent

- on the characteristic of the output current (e.g. harmonic content).
- on the real effective value of the motor current.
- on the cable length.
- on the type of the used cable.
- on the ambient conditions such as bundling and temperature.

5.3.4.7 Interconnection of the motor

NOTICE

Incorrect behavior of the motor!

- ▶ The connecting-up instructions of the motor manufacturer are always generally valid!

NOTICE

Protect motor against voltage peaks!

- ▶ Drive controllers switch at the output with high dV/dt. Voltage peaks that endanger the insulation system at the motor can occur especially in case of long motor cables (>15 m). A motor choke, a dV/dt filter or sine-wave filter can be used to protect the motor with regard to the operating mode.

5.3.4.8 Connection of the temperature monitoring and brake control (X1C)

A switchable temperature evaluation is implemented in the COMBIVERT.

There are different types for the evaluation available. These are depending on the control board => *Instruction manual „control board“*.

The desired operating mode can be adjusted via software (dr33). If the evaluation is not required, it must be deactivated via software (parameter pn12 = 7) => *Programming manual*.

| X1C | PIN | Name | Description |
|-----|-----|----------|----------------------------------|
| | 1 | BR+ | Brake control / output + |
| | 2 | BR- | Brake control / output - |
| | 3 | reserved | – |
| | 4 | reserved | – |
| | 5 | TA1 | Temperature detection / output + |
| | 6 | TA2 | Temperature detection / output - |

Figure 29: Terminal block X1C for control board APPLICATION and COMPACT

| X1C | PIN | Name | Description |
|-----|-----|----------|---------------------------------------|
| | 1 | BR+ | Brake control / output + |
| | 2 | BR- | Brake control / output - |
| | 3 | 0V | For supply of the checkback inputs |
| | 4 | 24Vout | |
| | 5 | DIBR1 | Checkback input 1 for brake and relay |
| | 6 | DIBR2 | Checkback input 2 for brake and relay |
| | 7 | reserved | – |
| | 8 | reserved | – |
| | 9 | TA1 | Temperature detection / output + |
| | 10 | TA2 | Temperature detection / output - |

Figure 30: Terminal block X1C for control board PRO

NOTICE

Malfunctions due to incorrect line or laying!

Malfunctions of the control due to capacitive or inductive coupling.

- ▶ Do not route cables from the motor temperature sensor (also shielded) together with control cables.
- ▶ Cables from the motor temperature sensor within the motor cables may only be used with double shielding!
- ▶ The input of the temperature detection has basic isolation.

| | | |
|---|-----------|---|
| | | <p>For control board APPLICATION and COMPACT. The voltage to the control of a brake is decoupled from the internal voltage supply. The brake works only with external voltage supply.</p> <p>For control board PRO The brake can be supplied with both, internal and external voltage. Voltage tolerances and output currents vary for internal and external voltage supply..</p> |
| 1 | COMBIVERT | <p>Respect the specifications => Instruction manual „control board“</p> |
| 4 | Brake | |
| <p>Figure 31: Connection of the brake control</p> | | |

| | | |
|--|--|--|
| | | <p>KTY sensors are polarized semiconductors and must be operated in forward direction! To this connect the anode to TA1 and the cathode to TA2! Non-observance leads to incorrect measurements in the upper temperature range. A protection of the motor winding is then no longer guaranteed.</p> |
| 1 | Connection via shield plate (if not available, place on the mounting plate). | |
| <p>Figure 32: Connection of a KTY sensor</p> | | |

NOTICE

No protection of the motor winding in case of wrong connection.

- ▶ Operate KTY sensors in forward direction.
- ▶ KTY sensors may not be combined with other detections.



Further information about the wiring of the temperature monitoring and the brake control have to be observed in the respective control unit manual.

5.3.5 Connection and use of a braking resistor

⚠ CAUTION**Fire risk by using brake resistors !**

- ▶ The risk of fire can be significantly reduced by using „intrinsically safe braking resistors“ or by using suitable monitoring functions / circuits.

NOTICE**Destruction of the frequency inverter if the value has fallen below the minimum brake resistance value!**

- ▶ The minimum brake resistance value must not fall below!
„3.2 Device data of the 400 V devices“

⚠ CAUTION**Hot surfaces caused by load of the braking resistor!****Burning of the skin!**

- ▶ Cover hot surfaces safe-to-touch.
- ▶ Before touching, check the surface.
- ▶ If necessary, attach warning signs on the system.

5.3.5.1 Terminal block X1A connection braking resistor

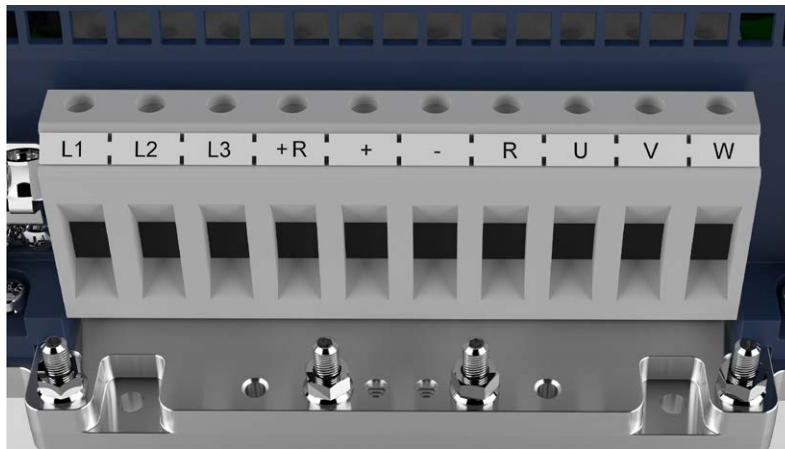

| Name | Function | Cross-section for terminal connection | Tightening torque | Max. number of conductors |
|------|--|--|---------------------------------|-----------------------------|
| +R | Connection for braking resistor (between +R and R) | Flexible cable with wire end ferrule 1.5...35 mm ² (without wire end ferrule up to max. 50 mm ²) For 2 conductors max. 16 mm ² UL: Flexible cable without wire-end ferrule AWG 16...1 | 3.2...3.7 Nm 28...32 lb inch | For IEC: 2 For UL: 1 |
| R | | | | |

Figure 33: Terminal block X1A connection braking resistor

5.3.5.2 Use of intrinsically safe braking resistors

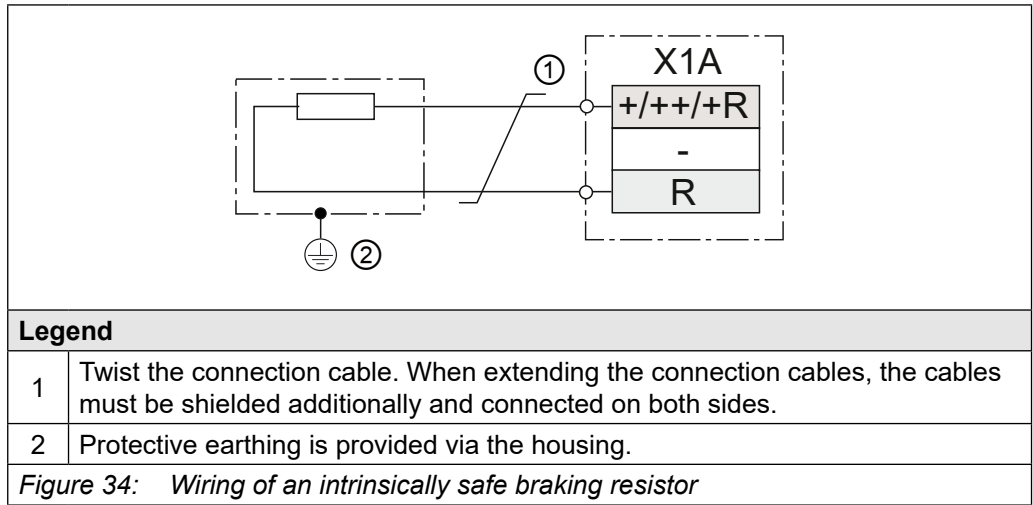

Intrinsically safe braking resistors behave in error case such as a safety fuse. They interrupt themselves without fire risk.

More information about intrinsically safe braking resistors

www.keb.de/fileadmin/media/Manuals/dr/ma_dr_safe-braking-resistors-20106652_en.pdf



5.3.5.3 Use of non-intrinsically safe braking resistors

⚠ WARNING



Use of non-intrinsically safe braking resistors

Fire or smoke emission in case of overload or error!

- ▶ Only use braking resistors with temperature sensor.
- ▶ Evaluate temperature sensor.
- ▶ Trigger an error at the drive controller (e.g. external input).
- ▶ Switch off input voltage (e.g. input contactor).
- ▶ Connection examples for non-intrinsically safe braking resistors
- ▶ => *Instructions for use "Installation braking resistors"*



Instructions for use "Installation braking resistors"

www.keb.de/fileadmin/media/Manuals/dr/ma_dr_braking-resistors-20116737_en.pdf

Chapter „Connection of a braking resistor with extended temperature monitoring“.



5.3.6 DC-bus connection

The DC link of several drive controllers are coupled in a DC-bus connection. This enables energy to be exchanged between the devices and increases the energy efficiency of the application.

As part of a DC-bus connection, this drive controller can either be supplied via the DC terminals => „5.3.6 DC-bus connection“ or supply other drive controllers via the DC terminals => „5.3.2 AC mains connection“.



KEB drive controllers meet the requirements of the EMC product standard *EN IEC 61800-3* for DC power supplies. Due to the large number of possible interconnection options in the DC network, the user is responsible for ensuring the conformity of the overall system.

The following additional safety instructions must be observed when using this drive controller in a DC-bus connection:

- This drive controller may only be operated together with other F6 and S6 drive controllers of the 400V class in a DC-bus connection.
- This drive controller must be installed in an enclosure.
- This drive controller must be protected with fuses at the DC terminals => „3.3.6.2 Fuse protection for DC supply“.
- If one fuse in the DC-bus connection blows as a result of a short circuit, all fuses in the DC-bus connection should be replaced due to the risk of prior damage.
- The parameterisation of the input phase failure detection must be adapted => F6 Programming manual.

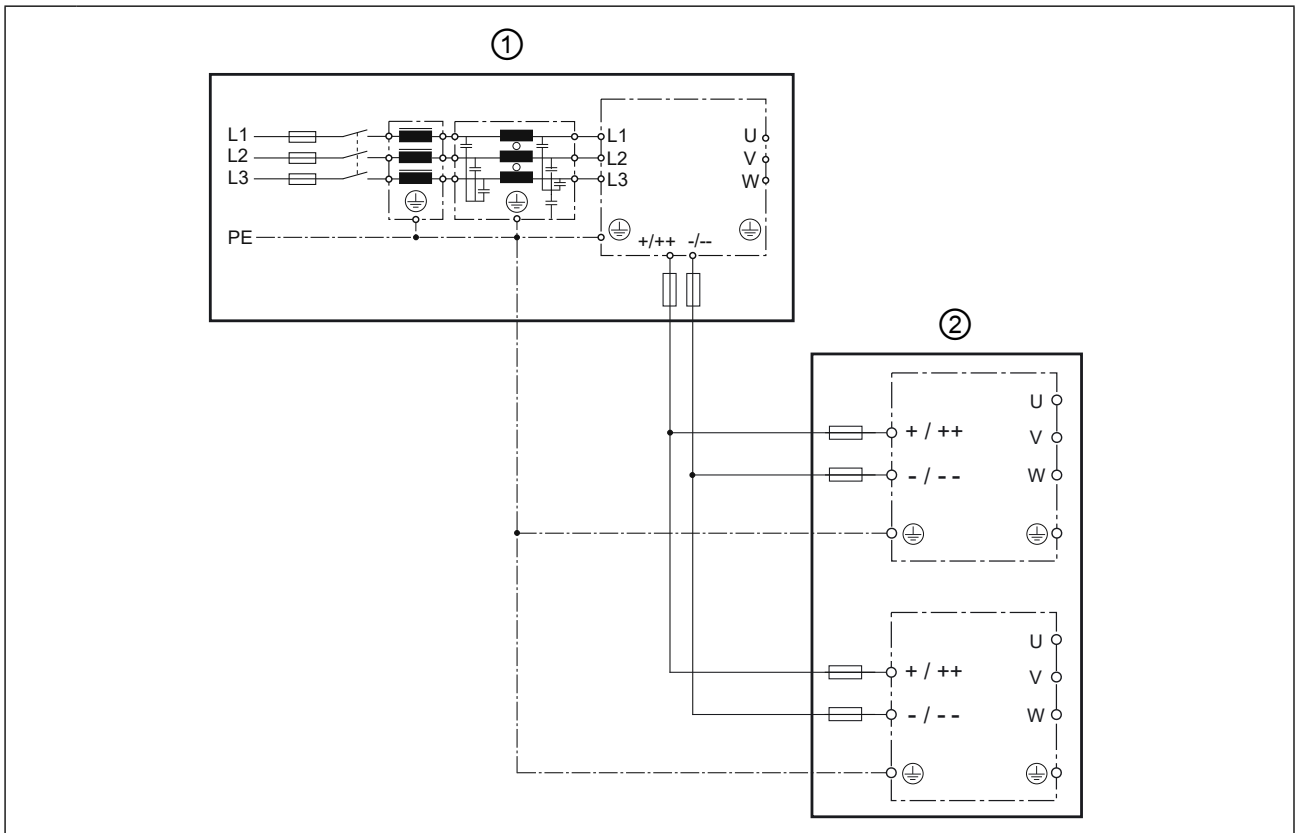

| Legend | |
|--------|--|
| 1 | Drive controller for supplying further drive controllers |
| 2 | Other drive controllers connected to the DC-bus connection |

Figure 35: DC-bus connection

① When using this drive controller to supply other drive controllers via the DC terminals, the following must also be observed:

- The maximum prechargeable total capacity (internal capacity + external capacity) must not be exceeded => „Table 34: DC link / braking transistor function of the 400 V peak power devices“.
- The minimum waiting time between two precharging procedures must be observed => „5.2.1 Connection of the voltage supply“.
- Drive controllers supplied via the DC terminals must not be loaded during precharging.
- Overloading of the rectifier must be prevented by the user => „3.3.4 Overview of rectifier data for 400 V devices“.

② When supplying this drive controller via the DC terminals, the following must also be observed:

- The drive controller must be pre-charged by the supplying drive controller or an external pre-charging module.

5.4 Accessories

5.4.1 Filters and chokes

| Voltage class | Drive controller size | HF filter | Mains choke 50 Hz / 4% U_k |
|---------------|-----------------------|--------------|------------------------------|
| 230 V | 16 | 20E6T60-3000 | 16Z1B03-1000 |
| | 17 | 20E6T60-3000 | 17Z1B03-1000 |

Table 39: Filters and chokes for 230 V devices

| Voltage class | Drive controller size | HF filter | Mains choke 50 Hz / 4% U_k |
|---------------|-----------------------|--------------|------------------------------|
| 400 V | 18 | 18E6T60-3000 | 18Z1B04-1000 |
| | 19 | 20E6T60-3000 | 19Z1B04-1000 |

Table 40: Filters and chokes for 400 V devices



The specified filters and chokes are designed for rated operation.

5.4.2 Shield connection bracket mounting kit

| Name | Material number |
|--|-----------------|
| Shield connection bracket mounting kit | 00F6V80-4001 |

Table 41: Shield connection bracket mounting kit

5.4.3 Seal IP54-ready devices

| Name | Material number |
|-----------|-----------------|
| Seal IP54 | 40F6T45-0004 |

Table 42: Seal for IP54-ready devices

5.4.4 Side-mounted braking resistors



Technical data and design about intrinsically safe braking resistors => https://www.keb.de/fileadmin/media/Manuals/dr/ma_dr_safe-braking-resistors-20106652_en.pdf



Technical data and design about non-intrinsically safe braking resistors => https://www.keb.de/fileadmin/media/Manuals/dr/ma_dr_braking-resistors-20116737_en.pdf



6 Approvals and certifications

6.1 CE marking

The drive controller marked with a CE logo comply with the requirements specified by European Union directives. The CE Declaration of Conformity is available on the Internet at <https://www.keb-automation.com/search>.



For further information regarding the CE declarations of conformity
=> „6.3 Further informations and documentation“

6.2 UL certification

| | | |
|--|--|---------------------------|
| | Acceptance according to UL is marked at KEB drive controllers with the adjacent logo on the nameplate. | UL file number E167544 |
|--|--|---------------------------|

For conformity in accordance with UL for use on the North American and Canadian markets, the following additional instructions must be observed (English original text):

- All models: Maximum Surrounding Air Temperature: 45°C
- Use 75°C Copper Conductors Only
- Models 18F6, 19F6 and 20F6: Suitable For Use On A Circuit Capable Of Delivering Not More Than 5000 rms Symmetrical Amperes, 480 Volts Maximum when protected by Class J Fuses, see instruction manual for Branch Circuit Protection details.

All models: Suitable For Use On A Circuit Capable Of Delivering Not More Than 30000 rms Symmetrical Amperes, 480 Volts Maximum when protected by Semiconductor Fuses by SIBA, Type 20 189 20, or by EATON, Type 170M1368, or by motor controller, see instruction manual for Branch Circuit Protection details.

When DC supplied:

Suitable For Use On A Circuit Capable Of Delivering Not More Than 50000 rms Symmetrical Amperes, 680 Volts DC Maximum when protected by Semiconductor Fuses as Specified in the Manual.

CSA: For Canada, this marking shall be provided on the device or on a separate label shipped with the device.

Details of the prescribed Branch Circuit Protection as specified in the below section 'Branch Circuit Protection' of this Report need to be marked in the instruction manual.

- Integral solid state short circuit protection does not provide branch circuit protection. Branch circuit protection must be provided in accordance with the Manufacturer Instructions, National Electrical Code and any additional local codes.

CSA: For Canada: Integral solid state short circuit protection does not provide branch circuit protection. Branch circuit protection must be provided in accordance with the Canadian Electrical Code, Part I"

- For installations according to Canadian National Standard C22.2 No. 274-13: For use in Pollution Degree 2 and Overvoltage Category III environments only.
- Control Circuit Overcurrent Protection Required or equivalent.
- WARNING – The opening of the branch circuit protective device may be an indication that a fault current has been interrupted. To reduce the risk of fire or electrical shock, current-carrying parts and other components of the controller should be examined and replaced if damaged. If burnout of the current element of an overload relay occurs, the complete overload relay must be replaced.
- Internal Overload Protection Operates prior to reaching the 130% of the Motor Full Load Current, see manual for adjustment instructions or equivalent wording.

- External break resistor ratings and duty cycle:
 - Duty cycle 50%
 - Max. 60 sec on-time, (60 sec off-time)
- Internal break resistor ratings and duty cycle:
 - Duty cycle 0.79%
 - Max. 0.95 sec on-time, (119.05 sec off-time)

6.3 Further informations and documentation

You find supplementary manuals and instructions for the download under www.keb-automation.com/search

General instructions

- EMC and safety instructions
- Manuals for additional control boards, safety modules, fieldbus modules, etc.

Instruction and information for construction and development

- Input fuses in accordance with UL
- Programming manual for control and power unit
- Motor configurator to select the appropriate drive controller and to create downloads for parameterizing the drive controller

Approvals and approbations

- Declaration of conformity CE
- TÜV certificate
- FS certification

Other markings and approvals not listed here are identified by a corresponding logo on the rating plate or device, if applicable. The corresponding certificates are available on our website.

Others

- COMBIVIS, the software for comfortable parameterization of drive controllers via PC (available per download)
- EPLAN drawings

7 Revision history

| Version | Date | Description |
|---------|---------|--|
| 00 | 2024-05 | Pre-series version of the manual created. |
| 01 | 2024-08 | Adding of the 230 V devices |
| 02 | 2025-07 | UL text updated. Information on motor circuit-breaker and circuit breaker added.. Description of 400 V DC-ready devices added. |
| 03 | 2025-11 | Size 17 devices with 230 V added.Editorial changes. |

Glossary

| | | | |
|-------------------------|--|-------------------|---|
| 0V | Earth-potential-free common point | Encoder emulation | Software-generated encoder output |
| 1ph | 1-phase mains | End customer | The end customer is the user of the customer product |
| 3ph | 3-phase mains | Endat | Bidirectional encoder interface of the company Heidenhain |
| AC | AC current or voltage | EtherCAT | Real-time Ethernet bus system of the company Beckhoff |
| AFE | From 07/2019 AIC replaces the previous name AFE | Ethernet | Real-time bus system - defines protocols, plugs, types of cables |
| AFE filter | From 07/2019 AIC filter replaces the previous name AFE filter | FE | Functional earth |
| AIC | Active Infeed Converter | FSoE | Functional Safety over Ethernet |
| AIC filter | Filter for Active Infeed Converter | FU | Drive controller |
| Application | The application is the intended use of the KEB product | GND | Reference potential, ground |
| ASCL | Asynchronous sensorless closed loop | GTR7 | Braking transistor |
| Auto motor ident. | Automatically motor identification; calibration of resistance and inductance | HF filter | KEB specific term for an EMC filter (for description see EMC filter). |
| AWG | American wire gauge | Hiperface | Bidirectional encoder interface of the company Sick-Stegmann |
| B2B | Business-to-business | HMI | Human machine interface (touch screen) |
| BiSS | Open source real-time interface for sensors and actuators (DIN 5008) | HSP5 | Fast, serial protocol |
| CAN | Fieldbus system | HTL | Incremental signal with an output voltage (up to 30V) -> TTL |
| c.d.f. | Cyclic duration factor | IEC | IEC xxxxx stands for an international standard of the International Electrotechnical Commission |
| CDM | Complete drive module including auxiliary equipment (control cabinet) | IPxx | Protection class (xx for class) |
| COMBIVERT | KEB drive controller | KEB product | The KEB product is subject of this manual |
| COMBIVIS | KEB start-up and parameterizing software | KTY | Silicium temperature sensor (polarized) |
| Customer | The customer has purchased a KEB product from KEB and integrates the KEB product into his product (customer product) or resells the KEB product (dealer) | Manufacturer | The manufacturer is KEB, unless otherwise specified (e.g. as manufacturer of machines, engines, vehicles or adhesives) |
| DC | DC current or voltage | MCM | American unit for large wire cross sections |
| DI | Demineralized water, also referred to as deionized (DI) water | Modulation | Means in drive technology that the power semiconductors are controlled |
| DIN | German Institut for standardization | MTTF | Mean service life to failure |
| DS 402 | CiA DS 402 - CAN device profile for drives | NHN | Standard elevation zero; based on the specified height definition in Germany (DHHN2016). The international data generally deviate from this by only a few cm to dm, so that the specified value can be applied to the regionally applicable definition. |
| ELV | Extra-low voltage | OC | Overcurrent |
| EMC filter | EMC filters are used to suppress conducted interferences in both directions between the drive controller and the mains | OH | Overheat |
| Emergency stop | Shutdown of a drive in emergency case (not de-energized) | OL | Overload |
| Emergency switching off | Switching off the voltage supply in emergency case | | |
| EMS | Energy Management System | | |
| EN | European standard | | |

| | |
|--------|--|
| OSSD | Output signal switching device; - an output signal that is checked in regular intervals on its shutdown. (safety technology) |
| PDS | Power drive system incl. motor and measuring probe |
| PE | Protective earth |
| PELV | Protective Extra Low Voltage |
| PFD | Term used in the safety technology (EN 61508-1...7) for the size of error probability |
| PFH | Term used in the safety technology (EN 61508-1...7) for the size of error probability per hour |
| PLC | Programmable logic controller |
| Pt100 | Temperature sensor with $R_0=100\Omega$ |
| Pt1000 | Temperature sensor with $R_0=1000\Omega$ |
| PTC | PTC-resistor for temperature detection |
| PWM | Pulse width modulation |
| RJ45 | Modular connector with 8 lines |
| SCL | Synchronous sensorless closed loop |
| SELV | Safe extra-low voltage, unearthed |
| SIL | The safety integrity level is a measure for quantifying the risk reduction. Term used in the safety technology (EN 61508 -1...7) |
| SS1 | Safety function „Safe stop 1“ in accordance with IEC 61800-5-2 |
| SSI | Synchronous serial interface for encoder |
| STO | Safety function „Safe Torque Off“ in accordance with IEC 61800-5-2 |
| TTL | Logic with 5 V operating voltage |
| USB | Universal serial bus |
| VARAN | Real-time Ethernet bus system |

List of Figures

| | | |
|------------|--|----|
| Figure 1: | Nameplate (exemplary)..... | 22 |
| Figure 2: | Configurable options | 23 |
| Figure 3: | Switch-off time t depending on the overload I/IN at OC level 260 % (OL)..... | 30 |
| Figure 4: | Switch-off time t depending on the overload I/IN at OC level 270 % (OL)..... | 31 |
| Figure 5: | Typical overload characteristics in the lower output frequencies (OL2) example device size 16 | 33 |
| Figure 6: | Switch-off time t depending on the overload I/IN at OC level 240 % (OL)..... | 40 |
| Figure 7: | Switch-off time t depending on the overload I/IN at OC level 270 % (OL)..... | 41 |
| Figure 8: | Typical overload characteristics in the lower output frequencies (OL2) example device size 19 | 43 |
| Figure 9: | Block diagram of the energy flow..... | 51 |
| Figure 10: | Switching behaviour of the fans example heat sink fan | 54 |
| Figure 11: | Dimensions built-in version air cooler | 55 |
| Figure 12: | Dimensions push-through version air cooler IP20, IP54-ready | 56 |
| Figure 13: | Mounting distances | 58 |
| Figure 14: | Installation of IP54-ready devices | 59 |
| Figure 15: | Control cabinet ventilation..... | 60 |
| Figure 16: | Airflow of the drive controller..... | 60 |
| Figure 17: | F6 housing 4 top view | 61 |
| Figure 18: | F6 housing 4 front view..... | 62 |
| Figure 19: | F6 housing 4 rear view with control board COMPACT | 63 |
| Figure 20: | Input circuit..... | 64 |
| Figure 21: | Terminal block X1A | 65 |
| Figure 22: | Connection for protective earth..... | 66 |
| Figure 23: | Connection of the mains supply 3-phase..... | 67 |
| Figure 24: | Terminal block X1A DC connection..... | 69 |
| Figure 25: | Connection at DC voltage supply..... | 70 |
| Figure 26: | Wiring of the motor..... | 71 |
| Figure 27: | Terminal block X1A motor connection..... | 72 |
| Figure 28: | Symmetrical motor line | 73 |
| Figure 29: | Terminal block X1C for control board APPLICATION and COMPACT..... | 75 |
| Figure 30: | Terminal block X1C for control board PRO | 75 |
| Figure 31: | Connection of the brake control..... | 76 |
| Figure 32: | Connection of a KTY sensor | 76 |
| Figure 34: | Wiring of an intrinsically safe braking resistor..... | 79 |
| Figure 35: | DC-bus connection | 81 |

List of Tables

| | | |
|-----------|--|----|
| Table 1: | Part code..... | 21 |
| Table 2: | Climatic environmental conditions | 24 |
| Table 3: | Mechanical environmental conditions | 25 |
| Table 4: | Further environmental operating conditions..... | 25 |
| Table 5: | Device classification..... | 26 |
| Table 6: | Electromagnetic compatibility | 26 |
| Table 7: | Overview of the 230V Peak Power device data..... | 28 |
| Table 8: | Input voltages and frequencies of the 230V devices | 28 |
| Table 9: | DC link voltage for 230V devices | 28 |
| Table 10: | Output voltages and frequencies of the 230V devices | 29 |
| Table 11: | Example of the calculation of the possible motor voltage 230V | 29 |
| Table 12: | Input and output currents of the 230 V peak power devices..... | 29 |
| Table 13: | Frequency-dependent maximum current for device size 16 peak power | 34 |
| Table 14: | Frequency-dependent maximum current for device size 17 peak power | 35 |
| Table 15: | Power dissipation of the 230 V peak power devices | 36 |
| Table 16: | Fusings for 230 V peak power devices | 36 |
| Table 17: | Overview of the 400V Peak Power device data..... | 38 |
| Table 18: | Input voltages and frequencies of the 400V devices | 38 |
| Table 19: | DC link voltage for 400V devices | 38 |
| Table 20: | Output voltages and frequencies of the 400V devices | 39 |
| Table 21: | Example of the calculation of the possible motor voltage: | 39 |
| Table 22: | Input and output currents of the 400 V peak power devices..... | 39 |
| Table 23: | Frequency-dependent maximum current for device size 18 peak power | 44 |
| Table 24: | Frequency-dependent maximum current for device size 19 peak power | 45 |
| Table 25: | Overview of rectifier data for 400 V devices | 45 |
| Table 26: | Power dissipation of the 400 V peak power devices | 46 |
| Table 27: | Fusings for 400 V peak power devices | 46 |
| Table 28: | DC Fusing of the 400 V / 480V devices | 47 |
| Table 29: | Recommended motor protective circuit-breakers / circuit breakers for 400 V / 480 V appliances..... | 48 |
| Table 30: | Alternative motor protective circuit-breakers / circuit breaker for 400 V / 480 V appliances..... | 49 |
| Table 31: | Switching frequency and temperature for 230 V peak power devices..... | 50 |
| Table 32: | Switching frequency and temperature for 400 V peak power devices..... | 50 |
| Table 33: | DC link / braking transistor function of the 230V peak power devices | 52 |
| Table 34: | DC link / braking transistor function of the 400V peak power devices | 53 |
| Table 35: | Fan..... | 53 |
| Table 36: | Switching points of the fans | 54 |
| Table 37: | Mounting instructions for built-in version..... | 57 |
| Table 38: | Fastening instructions for push-through version | 57 |
| Table 39: | Filters and chokes for 230 V devices..... | 82 |
| Table 40: | Filters and chokes for 400 V devices..... | 82 |
| Table 41: | Shield connection bracket mounting kit | 82 |
| Table 42: | Seal for IP54-ready devices..... | 82 |





MORE KEB PARTNERS WORLDWIDE:

www.keb-automation.com/contact





Automation with Drive

www.keb-automation.com

KEB Automation KG Suedstrasse 38 D-32683 Barntrop Tel. +49 5263 401-0 E-Mail: info@keb.de