



LIFT TECHNOLOGY

AUTOMATION AND DRIVE SOLUTIONS

EN



KEB



HIGHLIGHTS

- Power range: 0.75 kW ... 450 kW – 400 / 480 V and 0.75 kW ... 45 kW – 200 V
- Compact design
- Flexible motor operation: for asynchronous/synchronous motors, with or without gearbox
- Encoderless control for asynchronous/synchronous motors
- Overload capacity – over 200 % for demanding loads
- High switching frequency – up to 16 kHz for quiet, low-vibration operation

SYSTEM SOLUTIONS

INTELLIGENT DRIVE TECHNOLOGY FOR MODERN LIFT SYSTEMS

The requirements for modern lift systems are high: energy efficiency, ride comfort and seamless system integration are the focus. Powerful and intelligent drive solutions play a central role here – they determine the dynamics and precision of the movement, influence energy consumption and create the connection to building automation.

KEB Automation offers a comprehensive portfolio for this purpose: frequency inverters, regenerative systems, EMC filters and components for power quality assurance. Among other things, these technologies enable the precise control of synchronous and asynchronous motors. As a specialist in drive and automation technology, KEB develops and manufactures high-performance systems – from control systems to motor shafts. Flexible integration, long-lasting quality and compliance with standards make these solutions the first choice for demanding lift applications.

IIoT



SOFTWARE

Visualisation



HMI

Engineering



Control Software

Remote Control

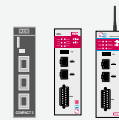

Router

CONTROL



Web HMI



Embedded Control



IPC



I/O



Safety PLC

DRIVES



Inverter



Servo Drive



Drive Controller



Pitch Drive

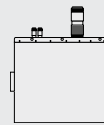

eMobility Drive

MOTORS



PM Motor



AC Motor



PM Gear Motor



AC Gear Motor

BRAKES & CLUTCHES



Permanent Magnet Brake



Spring Applied Brake



Electromagnetic Brake



Electromagnetic Clutch

LIFT DRIVES – COMBIVERT F6 AND S6

FREQUENCY INVERTERS IN LIFTS – THE HEART OF MODERN DRIVE ELECTRONICS

Frequency inverters are the central element in the electronic drive control of modern lift systems. They enable the speed and torque of the motor to be precisely regulated – regardless of load or lifting height – thus ensuring smooth, gentle and energy-efficient operation.

KEB offers the COMBIVERT F6 and S6 drive controllers for lift construction – enhanced with a special lift feature. A software package designed for lift operation ensures maximum safety and allows you to benefit from additional functionalities. F6 and S6 combine maximum control quality, robust design and maximum flexibility – all in a compact space.

Thanks to their compact design, the drives can be easily integrated even in limited space. The device series together cover a wide power range from 0.75 kW to 450 kW and are suitable for both gearless and geared motors – regardless of whether they are synchronous or asynchronous machines. Encoderless operation is also possible, which gives the user additional freedom in system design.

For particularly demanding driving situations, the F6 and S6 Lift drives offer high overload capacities up to 250 %. At the same time, it allows a switching frequency of up to 16 kHz, enabling extremely low-noise and low-vibration operation – ideal for applications with increased comfort requirements. Intelligent power adjustment ensures that the drive functions reliably at all times.



Functional safety

STO (Safe Torque Off)
SBC (Safe Brake Control)

LCD display

Display, USB, Ethernet

Diagnostic interface

Drive monitoring

Brake control 24 V / 2A
Brake monitoring
Motor temperature measurement

Mains connection

Braking resistor + DC connection

Interfaces

CANopen, Ethernet,
serial RS-232/485

I/O

8 digital inputs
2 digital outputs
1 relay
2 analog inputs
1 analog output
24 V DC power supply

Status LEDs

Multi-encoder interfaces

SinCos, EnDAT, BiSS, SSI,
HIPERFACE, Resolver,
Incremental HTL/TTL
Incremental output

Motor connection

Control:

Bus:  CANopen Lift (CiA 417),
DCP 3 +4, KEB Lift Protocol, DIN 66019, Ethernet TCP/IP
Terminals: digitally input-coded, binary-coded, analog 0-10 V

Certified according to:

UL, CE, UKCA, FS EN81-20/50, ASME A17.1/CSA B44



HIGHLIGHTS

- Automatic inertia determination for the entire system
- Ogive function enhances short travel
- Travel counter and direction change counter
- Emergency travel programs in the event of earthquakes, evacuations, etc.
- Lift operator
- Universal control via CANopen Lift, DCP, serial, Ethernet, digital parallel, analog and more
- Event and error logs with time stamp
- Automatic calibration of motor data
- Synthetic pre-torque
- Brake chopper monitoring with safe shutdown
- Encoderless emergency operation of synchronous motors
- Adaptive speed profile with limited mains power

HIGHLIGHTS

- STO for operation without motor starters
- Motor and encoder identification with brake closed
- Connection for brake monitoring microswitch
- Motor protection switch, configurable in the software
- Motor test before each run for short circuit, earth fault, wire break, etc.
- UPS operation
- Overspeed monitoring
- Speed deviation monitoring
- Motor blockage monitoring
- Unintentional movement, standstill monitoring, emergency functions such as UPS evacuation, earthquake, evacuation, ...
- Trip counter, counter for change of direction (belt change)
- Earth fault monitoring
- Storage space for OEM-specific parameterisation
- Easy commissioning thanks to guided parameterisation

CONTROL WITH LIFT-OPERATOR

- Intuitive operation
- Lift terminology, 7 languages
- Choice of metric or imperial units
- USB and Ethernet interfaces
- Detailed diagnostics and data logging
- 5-level parameter password protection
- Custom parameter library available
- Memory space and real-time clock
- Detailed diagnostics
- Also suitable as a remote display



Optional LCD display especially for the lift application

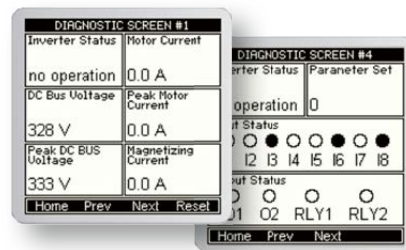

Graphic displays for quick diagnosis

COMBIVIS DRIVE SOFTWARE

Our integrated software products support you in various areas of the process chain, from planning to commissioning, diagnostics and troubleshooting. They simplify operation and offer great flexibility in adapting your drives to reduce time and costs.

Scope function: Multi-channel digital oscilloscope for recording and displaying measured variables. Ideal for fine-tuning the lift.

For easy parameterisation and management of your parameter lists.

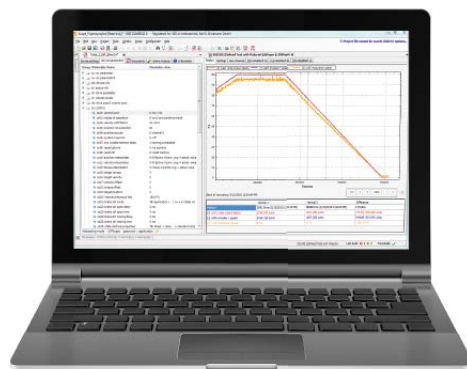

Safety is non-negotiable in lift construction. Drive systems must not only function reliably, but also actively contribute to the safety of people and machines. The functional safety of frequency inverters – in particular the integration of safe shutdown and monitoring functions – is an essential component of this.

NORMATIVE REQUIREMENTS

Lifts are subject to clearly defined safety standards, including:

- EN 81-20 / EN 81-50
- EN ISO 13849 and IEC 61508 / IEC 61800-5-2

These standards require a risk-based approach and often compliance with specific safety functions at a specified performance level (PL) or safety integrity level (SIL).

INTEGRATED SAFETY FUNCTIONS DIRECTLY IN THE DRIVE

Modern frequency inverters from KEB offer safety-related functions directly in the device – without separate safety relays or external hardware:



For operation without motor starters. The two-channel STO signal ensures safe shutdown of the motor torque. PL e / SIL3 certified. Direct connection of the motor offers many advantages. In addition to cost reduction through less material and wiring, there is also less EMC radiation. Sources of error are also reduced.



The internal SBC function (Safe Brake Control) monitors the motor brakes. Designated inputs are available for connecting the brake monitoring contacts. This ensures that the requirements for unauthorised movement (UCM) of the drive are met.

ADDITIONAL FUNCTIONS FOR MONITORING THE DRIVE:

MOTOR PHASE CHECK

The cable and motor windings are measured before each journey. An error is displayed in the event of irregularities such as a short circuit, earth fault, wire break, etc.

EVACUATION WITH UPS

Various modes are available. For example, if the UPS is undersized, the lift can be operated in the light mode. Here, the converter checks where the cabin is moving and then travels in a controlled manner to the desired floor. There are separate speeds, ramps and torque limits for UPS operation.

EVACUATION WITH SYNCHRONOUS MOTORS WITHOUT ENCODERS

If the encoder fails, the inverter can simply be set to open loop. This allows the cabin to be moved electrically in order to evacuate people or to move the cabin for repairs.

ADDITIONAL FUNCTIONS THAT MAKE THE LIFT SAFER:

- Blockage monitoring
- Overspeed
- Speed deviation
- Torque limitation
- Trip counter
- Internal monitoring of the brake chopper
- Software motor protection switch
- Motor and inverter temperature monitoring
- Temperature-dependent switching frequency reduction
- Delay monitoring for shortened shafts
- Modes for evacuation and earthquakes



ADVANTAGES FOR LIFT MANUFACTURERS

- Reduced complexity and fewer external components
- Simplified safety verification
- Less downtime in the event of faults
- Future-proofing for modifications and upgrades

EFFICIENT ENERGY USE IN LIFT OPERATION – COMBIVERT R6

Nowadays, the energy consumption of a lift is not only a question of cost, but also a decisive factor in the efficiency rating of buildings. Regenerative drive systems offer a clear advantage here: instead of converting the energy generated during braking into heat via resistors, it is efficiently fed back into the building grid and utilised.

RECOVER ENERGY INSTEAD OF WASTING IT

The motor acts as a generator, particularly in driving situations such as travelling downwards with a loaded cabin or upwards with an empty cabin. The electrical energy generated in this process can be fed back into the grid using a suitable energy recovery module – cleanly, efficiently and economically.

POWER SUPPLY AND REGENERATIVE UNIT WITH SYSTEM ADVANTAGES

The COMBIVERT R6 from KEB is a compact and economical power supply and regenerative unit for the efficient use of braking energy. As a mains-powered power supply, the R6 enables a central DC supply for multiple drives – flexible and powerful, even under high continuous loads. When combined with harmonic filters, the R6 unit improves power quality, reduces reactive power and meets current EMC requirements. It also replaces conventional braking resistors, which not only reduces heat generation in the machine room but also potential fire risks. The system can be scaled flexibly thanks to the option of operating multiple units in parallel.

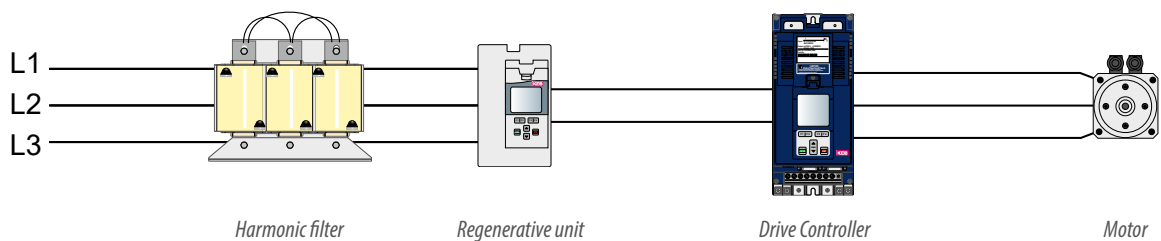

ACCESSORIES: EMC FILTER SYSTEMS, MAINS CHOKES AND BRAKES

In an increasingly electrified and connected building environment, electromagnetic compatibility (EMC) is essential for the smooth operation of all systems. Frequency inverters, as power electronic components, can cause significant interference if they are not adequately suppressed – from data errors in control lines to failures in neighbouring systems. Lift systems are subject to standards such as EN 12015 (interference emission) and EN 12016 (interference immunity). These standards specify limit values to ensure that the lift itself operates without interference and does not cause interference in the electrical environment.

FOR INTERFERENCE-FREE AND STANDARD-COMPLIANT OPERATION

KEB offers matching EMC filter solutions and choke technology that are optimally harmonised with the company's own frequency inverters. Various components are used to ensure compliance with the relevant standards:

MAINS FILTER FOR LIMITING HIGH-FREQUENCY INTERFERENCE ON THE MAINS SIDE: EMC FILTER COMBILINE E6

- Very low leakage currents
- Perfectly suited for operation with modern RCDs
- Compact book-shaped design with small mounting surface, alternatively available as an sub-mounted filter
- High EMC attenuation, designed for shielded motor cable lengths of up to 100 m or 300 m



MAINS FILTER FOR SINUSOIDAL CURRENT CONSUMPTION:

HARMONIC FILTER COMBILINE Z1C

- Reduction of THDi to below 8 % and PWHD to below 15 % – for clean power quality
- High overload capacity up to 150 % and efficiency of over 99 %
- Compact, ready-to-connect design – no additional wiring required
- Suitable for multiple parallel loads and for use with dynamic load changes

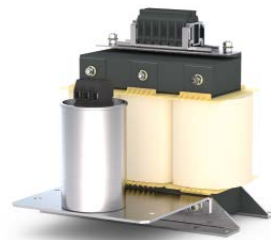

MAINS CHOKES FOR SMOOTHING THE CURRENT FLOW AND REDUCING THE THDI VALUE (TOTAL HARMONIC DISTORTION):

COMBILINE Z1 MAINS CHOKE

- Universally applicable mains chokes for single-phase and three-phase consumers
- Space-saving rear panel installation with EMC filter wires possible
- Relief for cables and transformers, mains harmonic optimisation
- Protection and longer service life for rectifiers and electrolytic capacitors



BRAKING RESISTORS

KEB offers a wide range of braking resistors suitable for use in hoists for your specific application.

- Braking resistors in aluminium housings for the lower power range
- Braking resistors in steel tube housings for the upper power range
- Intrinsically safe versions and versions with integrated temperature switches available
- Low noise emissions



PRECISE POSITIONING, SECURE HOLDING:

COMBINORM AND COMBISTOP BRAKES

- Ideal for use in the mechanisms of revolving doors or escalators
- Various sizes with short switching times available
- Designed for 100 % duty cycle
- Spring-applied brakes for HomeLift, small goods lifts and stair lifts in the portfolio
- Double brakes available



BENEFITS FOR THE USER

Targeted filtering and choking enable manufacturers and operators to benefit from:

- Safe, standard-compliant operation
- Minimised susceptibility to interference from other building systems
- Increased service life of all electronic components
- Simplified certification of the entire system



KEB

Greater efficiency, safety and flexibility for your lift system

– individually implemented in accordance with standards using modular drive technology from KEB.



GOODS LIFTS

For transporting heavy or bulky goods, such as in warehouses, industrial plants or department stores.

- COMBIVERT F6/R6: For high outputs up to 450 kW and flexible energy recovery solutions
- Connection to common industrial fieldbus systems such as EtherCAT, PROFINET or CANopen
- Robust industrial technology
- High input voltage

PASSENGER LIFTS

For the safe and comfortable transport of people in residential, office or public buildings.

- COMBIVERT F6/R6: For precise and energy-saving applications
- Low noise thanks to switching frequencies up to 16 kHz
- Synthetic Pre-Torque: Builds up a defined torque before releasing the brake – for smooth starts and maximum ride comfort
- Quiet braking resistors
- Evacuation functions

SERVICE LIFTS

Specially designed for smaller transport goods or service items, often used in hotels, restaurants or libraries.

- COMBIVERT S6: Compact, space-saving solution for smaller transport capacities
- Power supply for 24 V motor brake in the converter
- COMBIVERT G6: Compact open-loop converter with built-in filter and display

MACHINE ROOM-LESS LIFTS

- Compact design for installation in the shaft or door frame
- Models with integrated EMC filter and pluggable terminals with touch protection
- Connection for remote display
- Various cooling solutions available
- 3C3 protective coating for circuit boards
- Quiet operation thanks to high switching frequency

TECHNICAL DATA COMBIVERT F6/S6 LIFT

COMBIVERT F6 LIFT

| HOUSING | | 2 | | | 3 | 4 | | 6 | | 8 | 9 |
|---------------------------------|-------|-----------------|--------|-------|-----------------|-----------------|--------|-----------------|--------|-----------------|-----------------|
| | | 14 | 15 | 16 | 17 | 18 | 19 | 21 | 22 | 26 | 29 |
| Device size | | | | | | | | | | | |
| Typical rated motor power | [kW] | 7.5 | 11 | 15 | 18.5 | 22 | 30 | 45 | 55 | 132 | 250 |
| Rated output power | [kVA] | 11.4 | 16.6 | 22.9 | 29 | 35 | 42 | 62 | 80 | 173 | 319 |
| Rated output current 400 V | [A] | 16.5 | 24 | 33 | 42 | 50 | 60 | 90 | 115 | 250 | 460 |
| Rated output current 480 V (UL) | [A] | 14 | 21 | 27 | 31,5 | 40 | 54 | 72 | 96 | 210 | 400 |
| Rated output overload (60 s) | [%] | 180 | 180 | 150 | 150 | 160 | 200 | 160 | 175 | 170 | 175 |
| | [A] | 29.7 | 43.2 | 49.5 | 63 | 80 | 120 | 144 | 201 | 425 | 805 |
| Software current limit | [%] | 200 | 200 | 190 | 180 | 200 | 250 | 200 | 225 | 227 | 216 |
| | [A] | 33 | 48 | 53.7 | 75.6 | 100 | 150 | 180 | 258 | 568 | 994 |
| Cut-off current | [%] | 240 | 240 | 230 | 216 | 240 | 270 | 240 | 270 | 275 | 260 |
| | [A] | 39.6 | 57.6 | 75.9 | 90.72 | 120 | 162 | 216 | 310 | 688 | 1196 |
| Rated input current 400 V | [A] | 21 | 31 | 43 | 55 | 59 | 66 | 99 | 126 | 263 | 485 |
| Rated input current 480 V (UL) | [A] | 18 | 27 | 35 | 41 | 48 | 59 | 79 | 106 | 217 | 414 |
| Min. / max. switching frequency | [kHz] | 2 / 16 | 2 / 16 | 2 / 8 | 2 / 16 | 2 / 16 | 2 / 16 | 2 / 16 | 2 / 16 | 2 / 8 | 2 / 8 |
| Mains phases | | 3 | | | | | | | | | |
| Input voltage range (AC) | [V] | 280 ... 550 | | | | | | | | | |
| Mains frequency | [Hz] | 50 / 60 ± 2 % | | | | | | | | | |
| Brake chopper | | internal | | | | | | | | | |
| Max. current brake chopper | [A] | 21.5 | 33.6 | 46.7 | 76 | 93 | 105 | 140 | 182 | 380 | 600 |
| Dimensions H x W x D | [mm] | 290 x 130 x 240 | | | 340 x 170 x 261 | 375 x 224 x 272 | | 525 x 249 x 272 | | 860 x 336 x 360 | 960 x 503 x 360 |

Other inverter sizes available on request.

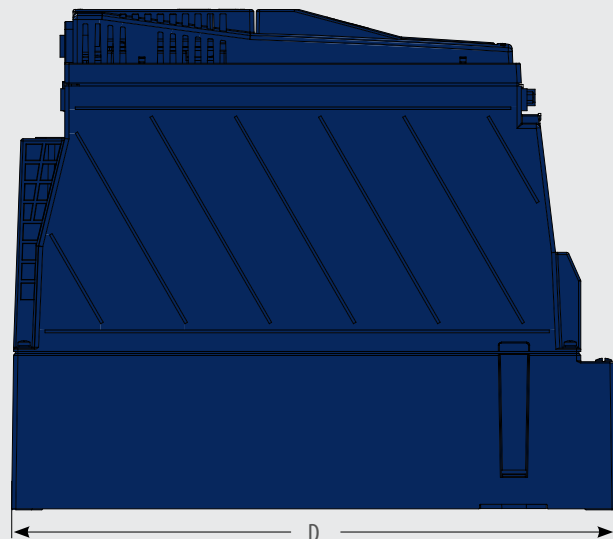
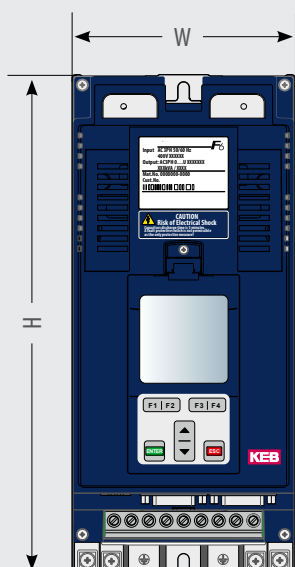

COMBIVERT S6 LIFT

| HOUSING | | 2 | | | | 4 | | |
|---------------------------------|-------|----------------|--------|----------------|--------|----------------|----------|--------|
| | | 07 | 09 | 09 | 10 | 12 | 13 | 14 |
| Device size | | | | | | | | |
| Typical rated motor power | [kW] | 0.75 | 1.5 | 1.5 | 2,2 | 4 | 5.5 | 7.5 |
| Rated output power* | [kVA] | 1.8 | 2.8 | 2.8 | 4 | 6.6 | 8.3 | 11.4 |
| Rated output current 400 V | [A] | 4 | 7 | 4.1 | 5.8 | 9.5 | 12 | 16.5 |
| Rated output overload (60 s) | [%] | 150 | 150 | 200 | 200 | 200 | 200 | 150 |
| | [A] | 6 | 10.5 | 8.2 | 11.6 | 19 | 24 | 24.8 |
| Overload (3 s) | [%] | 200 | 200 | 250 | 250 | 250 | 250 | 180 |
| | [A] | 8 | 14 | 10.2 | 14.5 | 23.7 | 30 | 29.7 |
| Cut-off current | [%] | 240 | 240 | 300 | 300 | 300 | 300 | 216 |
| | [A] | 9.6 | 16.8 | 12.3 | 17.4 | 28.5 | 36 | 35.6 |
| Rated input current | [A] | 8 | 14 | 6 | 8 | 13 | 17 | 21 |
| Min. / max. switching frequency | [kHz] | 4 / 16 | 4 / 16 | 4 / 16 | 4 / 16 | 4 / 16 | 4 / 16 | 4 / 16 |
| Mains phases | | 1 | | 3 | | | | |
| Input voltage range (AC) | [V] | 184 ... 265 | | 184 ... 550 | | | | |
| Mains frequency | [Hz] | 50 / 60 ± 2 % | | 50 / 60 ± 2 % | | | | |
| Mains filter | | internal | | internal | | | external | |
| Brake chopper | | internal | | | | | | |
| Max. current brake chopper | [A] | 7.5 | 12.7 | 8 | 11 | 28 | 34 | 34 |
| Dimensions H x W x D | [mm] | 310 x 50 x 220 | | 310 x 50 x 220 | | 310 x 90 x 220 | | |

*At nominal voltage 230 V / 400 V AC

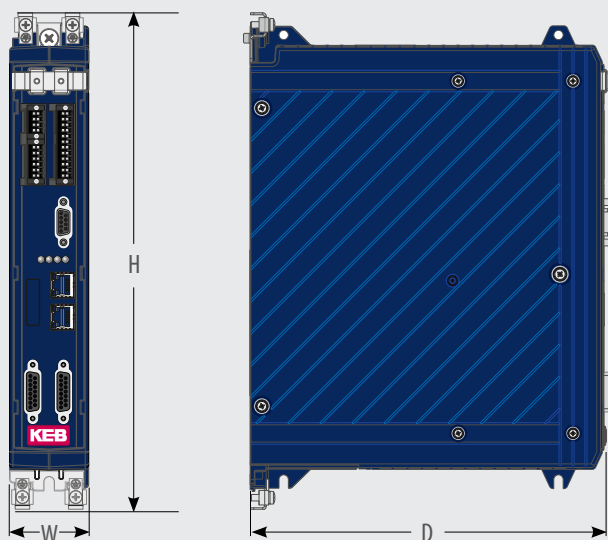



KEB'S COUNTRY ORGANISATIONS

Austria | KEB Automation GmbH

E-Mail: info@keb.at Web: keb-automation.com

Benelux | KEB Automation KG

E-Mail: info.benelux@keb.de Web: keb-automation.com

Czech Republic | KEB Automation s.r.o.

E-Mail: info@keb.cz Web: keb-automation.com

France | Société Française KEB SASU

E-Mail: info@keb.fr Web: keb-automation.com

Germany | **Geared Motors**

KEB Antriebstechnik GmbH

E-Mail: info@keb-drive.de Web: keb-automation.com

Germany | **Headquarters**

KEB Automation KG

E-Mail: info@keb.de Web: keb-automation.com

Italy | KEB Italia S.r.l. Unipersonale

E-Mail: info@keb.it Web: <https://blog.keb.it>

Japan | KEB Japan Ltd.

E-Mail: info@keb.jp Web: keb.jp

P. R. China | KEB Power Transmission Technology (Shanghai) Co. Ltd.

E-Mail: info@keb.cn Web: keb.cn

Poland | KEB Automation KG

E-Mail: roman.trinczek@keb.de Web: keb-automation.com

Republic of Korea | KEB Automation KG

E-Mail: vb.korea@keb.de Web: keb-automation.com

Spain | KEB Automation KG

E-Mail: vb.espana@keb.de Web: keb-automation.com

Switzerland | KEB Automation AG

E-Mail: info@keb.ch Web: keb-automation.com

United Kingdom | KEB (UK) Ltd.

E-Mail: info@keb.co.uk Web: keb-automation.com

United States | KEB America, Inc.

E-Mail: info@kebameric.com Web: kebameric.com

The information provided in this brochure contains merely general descriptions or characteristics of performance which in case of actual application do not always apply as described or which may change as a result of further development of the products. An obligation to provide the respective characteristics shall only exist if expressly agreed in the terms of contract. We reserve the right to make technical changes.

© KEB 06.2026

Automation with Drive

keb-automation.com

KEB Automation KG Suedstrasse 38 32683 Barntrup Germany Phone +49 5263 401-0 E-Mail: info@keb.de